



Series SA

General

The limit switches, or magnetic sensors, must be mounted on cylinders with magnetic piston.

These, when hit by the magnetic field generated by the piston as it approaches, close the circuit sending an electrical signal to relay, solenoid valve or converse with the controlling electronic system of the machine. There are both ampulla Reed and Hall effect magnetic sensor available. The sensors are attached to the cylinder by a proper clamp, slot or adapter and may have an activation LED indicator.

Note: The magnetic sensors are according to the Directive **EMC 89/336/CEE** and following amendments.

Instruction on how to use the sensors properly

Particular attention should be paid in order not to exceed the wide operating limits shown in the next pages. Besides, the 2 wires sensors have never to be connected to the mains if a load has not been yet connected in series. These are the only cares that, if not followed, may cause damages to the sensor. Besides, please consider that, while loading, the current absorbed by the sensors might be 50% higher than the rated one.

In case of direct current (DC) feeding, the polarity of the connection must be observed: the brown cable must be connected to the plus (+) and the blue one to the minus (-).

For all sensors, particular attention has to be paid to external factors (like, for example, nearby live cables, electromagnetic fields generated by electric motors, nearby metallic bodies, etc.) since they can affect the magnetic field generated by the magnet inside the piston and therefore causing malfunctions.

Electrical cable length must be kept below 10 meters in order to guarantee proper functioning.

If needed, 10 meters cable length can be exceeded; Pneumax suggests the use of an inductor or resistor in series to the load in order to reduce the capacitive behavior of the cable.

In this case, the customer is responsible for the selection of the inductor or resistor value. Pneumax assume no responsibility in case of malfunction.

When using a two wire Reed type sensor always ensure that the correct load is applied in series on any of the two wires.

When using a sensor fitted with the SNAP connector pay attention to the orientation of the connector (see fig. page 6.6) because by inverting the connection the circuit will not be damaged, but the LED will not turn on. In case two or more sensors need to be connected in series, pay attention to the voltage drop generated (around 3V for each sensor), and, in case, use the version designed for in series connection.

Hall effect sensors are longer lasting if compared to the Reed version since they do not include any moving mechanical part.



► Sensors with 2 wires cable (PUR Ø4,2 mm 2x0,34 mm²)

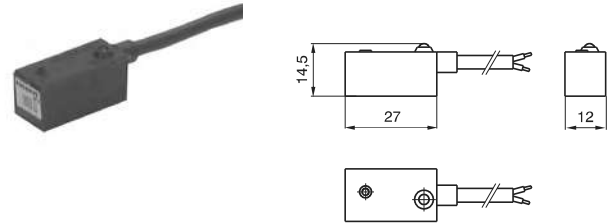
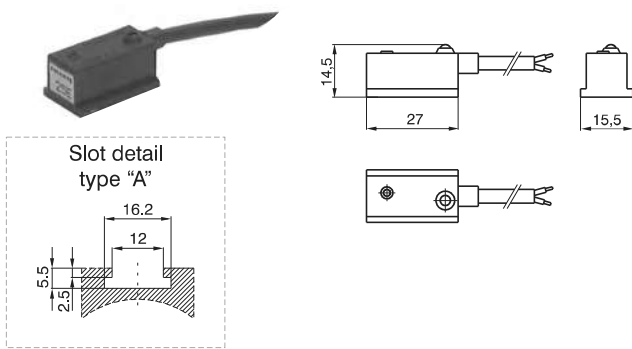

Diagrams and connections

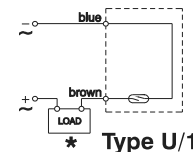
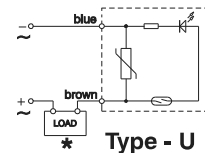
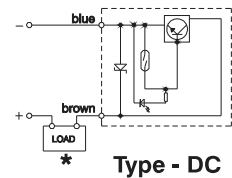
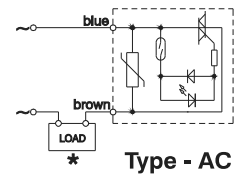

Ordering code

Cylinders and microbore cylinders	1500.AC	sensor for alternating current with led
	1500.DC	sensor for continuous current with led
	1500. U	universal sensor with led
	1500.U/1	universal sensor without led (REED ampulla only)
Rodless cylinders	1600.AC	sensor for alternating current with led
	1600.DC	sensor for continuous current with led
	1600.U	universal sensor with led
	1600.U/1	universal sensor without led (REED ampulla only)

Technical characteristics	A.C.	D.C.	U		U/1	
			a.c.	d.c.	a.c.	d.c.
Maximum permanent current	1,5A	1,2A	0,5A		0,3A	
Maximum current (pulses of 0,5 sec.)	6A	1,5A	1A		0,8A	
Voltage range	12 - 230V	12 - 30V	3 - 230V	12 - 48V	0 - 230V	0 - 48V
Maximum permanent power	375VA	32W	20VA	15W	10VA	8W
Working temperature	-20° C - 70°C					
Maximum voltage drop	3V max	2V max	3V max		0V	
Cable section	2x0,34 mm ² Ø4,2 mm PUR					
Degree of protection	IP 65					
Connecting time	2 ms					
Disconnecting time	1 ms					
Average working period	10 ⁷ cycles					
Repetition of intervention point	± 0,1 mm					
Type of contact	N.O.					

★The load (LOAD) can be connected either to negative or positive pole.

These sensors can be used on cylinders series:

SERIES	DESCRIPTION	MOUNTED
1200	for microbore with threaded end covers and "TECNO-MIR" microbore for microbore "MIR" with rolled end covers, cylinders from Ø16 to Ø32 for microbore "MIR-INOX" with rolled end covers	with clamps code 1260.Ø.F with clamps code 1280.Ø.F with clamps code 1280.Ø.FX
1306 - 1307 - 1308	for cylinders from Ø32 to Ø63 for cylinders from Ø80 to Ø125 for cylinders from Ø160 to Ø200	with brackets code 1306.A with brackets code 1306.B with brackets code 1306.C
1315	for cylinders Ø250 and Ø320 (ISO)	with brackets code 1306.D
1319 - 1320	for cylinders Ø32 and Ø40	with brackets code 1320.A
	for cylinders Ø50 and Ø63	with brackets code 1320.B
	for cylinders Ø80 and Ø100	with brackets code 1320.C
	for cylinders Ø125	with brackets code 1320.D
	for cylinders Ø160	with brackets code 1320.E
1390 - 1391	for cylinders Ø200	with brackets code 1320.F
	for cylinders ECOLIGHT Ø32 and Ø40	with brackets code 1390.A
	for cylinders ECOLIGHT Ø50 and Ø63	with brackets code 1390.B
	for cylinders ECOLIGHT Ø80 and Ø100	with brackets code 1390.C
1500	for cylinders ECOLIGHT Ø125 - Ø200 Compact cylinders "Europe" (from Ø32)	with brackets code 1390.D directly on groove

2 pin sensor for SNAP connector

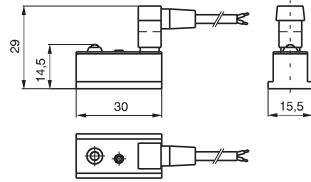

for cylinders and
microbore

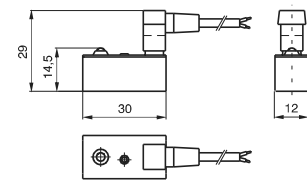
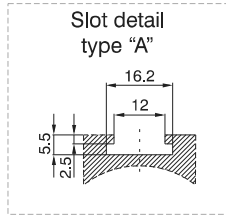

for rodless cylinders

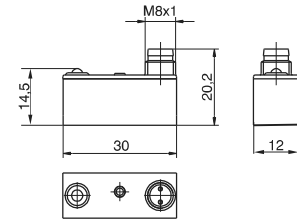
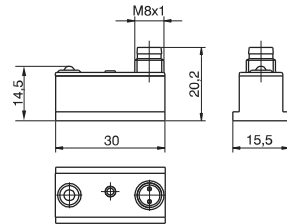

Ordering code

Cylinders and
microbore

RS.DC	sensor for continuous current with led normally open N.O.
RS.UA	universal sensor with led normally open N.O.
RS.UC	universal sensor with led normally closed N.C.
RS.UA/1	universal sensor without led N.O. (REED ampulla only)

Rodless cylinders

SRS.DC	sensor for continuous current with led normally open N.O.
SRS.UA	universal sensor with led N.O.
SRS.UC	universal sensor with led normally closed N.C.
SRS.UA/1	universal sensor without led N.O.

Cable

C1	connector with 2.5 m. cable 2 wires (PVC Ø3,5 mm 2x 0,25mm ²)
C2	connector with 5 m. cable 2 wires (PVC Ø3,5 mm 2x 0,25mm ²)
C3	connector with 10 m. cable 2 wires (PVC Ø3,5 mm 2x 0,25mm ²)

2 pin sensor for SNAP connector + C1 cable 2 wires (PVC Ø3.5 mm 2x0.25 mm²)

Cylinders and
microbore

RS.DCC1	sensor for DC current N.O. with LED and 2.5 m. cable
RS.UAC1	universal sensor with led N.O. with connector and 2.5 m. cable
RS.UCC1	universal sensor with led N.C. with connector and 2.5 m. cable
RS.UAC1/1	universal sensor without led N.O. with connector and 2.5 m. cable (REED ampulla only)

Rodless cylinders

SRS.DCC1	sensor for continuous current with led normally closed N.O. with connector and 2.5 m. cable
SRS.UAC1	universal sensor with led N.O. with connector and 2.5 m. cable
SRS.UCC1	universal sensor with led N.C. with connector and 2.5 m. cable
SRS.UAC1/1	universal sensor without led N.O. with connector and 2.5 m. cable (REED ampulla only)

2 pin sensor with M8 connector

Cylinders and
microbore

RS8.DC	sensor for DC current N.O. with LED and M8 plug
RS8.UA	universal sensor N.O. with LED and M8 plug
RS8.UC	universal sensor N.C. with LED and M8 plug

Rodless cylinders

SRS8.DC	sensor for DC current N.O. with LED and M8 plug
SRS8.UA	universal sensor N.O. with LED and M8 plug
SRS8.UC	universal sensor N.C. with LED and M8 plug

Cable

MCH1	cable 3 wires l=2.5m with M8 connector three wires (PUR Ø2.6 mm 3x 0.15 mm ²)
MCH2	cable 3 wires l=5m with M8 connector three wires (PUR Ø2.6 mm 3x 0.15 mm ²)



► 3 pin sensor for SNAP connector with 2 wires according to IEC 947 norms

Cylinders and microbore	RS.DCNO	sensor for continuous current with led normally open N.O., according to standard IEC 947
	RS.UANO	universal sensor with led normally open N.O., according to standard IEC 947
Cable	C1NO	connector with 2.5 m. cable, according to standard IEC 947 (PVC Ø3.5 mm 2x0.25 mm ²)
	C2NO	connector with 5 m. cable, according to standard IEC 947 (PVC Ø3.5 mm 2x0.25 mm ²)
	C3NO	connector with 10 m. cable, according to standard IEC 947 (PVC Ø3.5 mm 2x0.25 mm ²)

► 3 pin sensors for in series assembling with SNAP connector

Cylinders and microbore Rodless cylinders	RS.UA/1L	universal sensor with led normally open N.O., for series assembly (3 wires)
	SRS.UA/1L	universal sensor with led N.O., for series assembly (3 wires)
Cable	CH1	connector with 2.5 m. cable 3 wires (PVC Ø3.5 mm 3x0.25 mm ²)
	CH2	connector with 5 m. cable 3 wires (PVC Ø3.5 mm 3x0.25 mm ²)
	CH3	connector with 10 m. cable 3 wires (PVC Ø3.5 mm 3x0.25 mm ²)

► 3 pin sensors for in series assembling with SNAP conn. + CH1 cable 3 wires (PVC ø3.5mm 3x0.25 mm²)

Cylinders and microbore	RS.UACH1/1L	universal sensor with led N.O. with connector and 2.5 m. cable, for series mounting (3 wires)
Rodless cylinders	SRS.UACH1/1L	universal sensor with led N.O. with connector and 2.5 m. cable, for series assembly (3 wires)

► 3 pin sensors for in series assembling with M8 connector

Cylinders and microbore Rodless cylinders	RS8.UA/1L	universal sensor N.O. with LED for in series assembling (3wires) and M8 plug
	SRS8.UA/1L	universal sensor N.O. with LED for in series assembling (3wires) and M8 plug
Cable	MCH1	M8 connector with 2.5 m. cable 3 wires (PUR Ø2.6 mm 3x 0.15 mm ²)
	MCH2	M8 connector with 5 m. cable 3 wires (PUR Ø2.6 mm 3x 0.15 mm ²)
	MCH3	M8 connector with 10 m. cable 3 wires (PUR Ø2.6 mm 3x 0.15 mm ²)

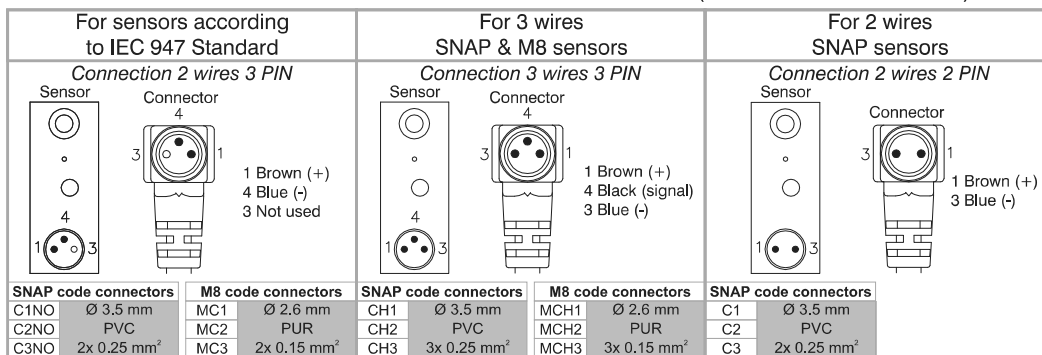

Technical characteristics	DC	UA				UA/1L		UA/1	
		a.c.		d.c.		a.c.	d.c.	a.c.	d.c.
Type of contact	N.O.	N.O.	N.C.	N.O.	N.C.	N.O.		N.O.	
Maximum permanent current	1.2A	0.5A	0.3A	0.5A	0.3A	0.5A		0.5A	
Maximum current (pulses of 0.5 sec.)	1.5A	1A	0.8A	1A	0.8A	1A		1A	
Voltage range	12 - 30V	3 - 250V	3 - 110V	12 - 48V		24V		0 - 250V	0 - 48V
Maximum permanent power	32W	20VA	10VA	15W	8W	20VA	15W	10VA	8W
Working temperature		-20°C - 70°C							
Maximum voltage drop	2V	<3V				0V			
Cables number		2				3		2	
Degree of protection		IP65							
Connecting time		2 ms							
Disconnecting time		1 ms							
Average working period		10 ⁷ cycles							

Diagrams and connections

Type - UA

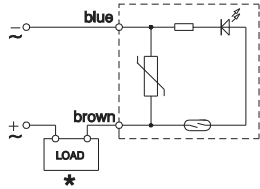

Type UA/1

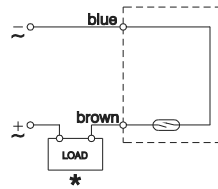

Type - UA/1L

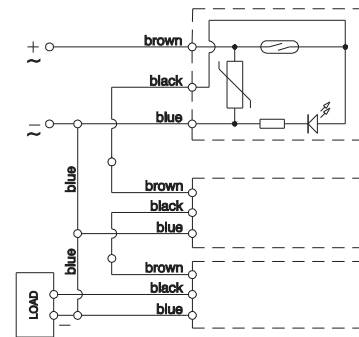

Type - DC

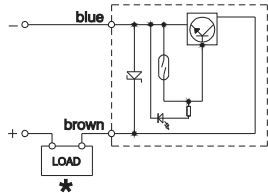

Type - DCNO

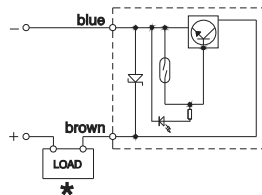

Type - UC

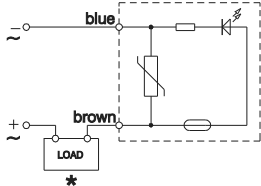

*The load (LOAD) can be connected either to negative or positive pole.

3 PNEUMATIC ACTUATION

These sensors can be used on cylinders series:

SERIES	DESCRIPTION	MOUNTED
1200	for microbore with threaded end covers and "TECNO-MIR" microbore for microbore "MIR" with rolled end covers, cylinders from Ø16 to Ø32 for microbore "MIR-INOX" with rolled end covers	with clamps code 1260.Ø.F with clamps code 1280.Ø.F with clamps code 1280.Ø.FX
1306 - 1307 - 1308	for cylinders from Ø32 to Ø63 for cylinders from Ø80 to Ø125 for cylinders from Ø160 to Ø200	with brackets code 1306.A with brackets code 1306.B with brackets code 1306.C
1315	for cylinders Ø250 and Ø320 (ISO)	with brackets code 1306.D
1319 - 1320	for cylinders Ø32 and Ø40	with brackets code 1320.A
	for cylinders Ø50 and Ø63	with brackets code 1320.B
	for cylinders Ø80 and Ø100	with brackets code 1320.C
	for cylinders Ø125	with brackets code 1320.D
1390 - 1391	for cylinders Ø160	with brackets code 1320.E
	for cylinders Ø200	with brackets code 1320.F
	for cylinders ECOLIGHT Ø32 and Ø40	with brackets code 1390.A
	for cylinders ECOLIGHT Ø50 and Ø63	with brackets code 1390.B
1500	for cylinders ECOLIGHT Ø80 and Ø100	with brackets code 1390.C
	for cylinders ECOLIGHT Ø125 - Ø200	with brackets code 1390.D
	Compact cylinders "Eurosens" (from G20)	directly on groove



► Sensors with 3 wires cable PUR \varnothing 4.2 mm 3x0.34mm²)

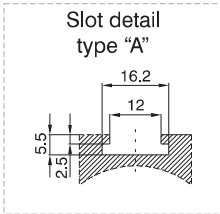
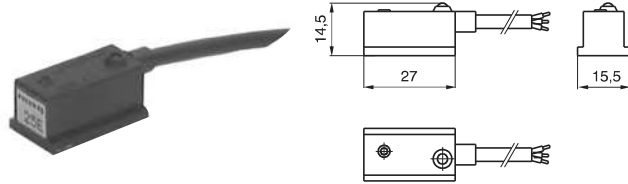

for cylinders and microbore

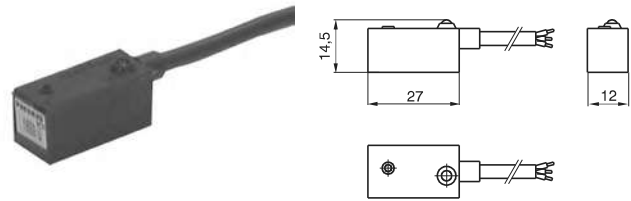

for rodless cylinders

Ordering code

Cylinders and microbore	1500.HAP	PNP sensor Hall effect with led, normally open N.O.
	1500.HAN	NPN sensor Hall effect with led, normally open N.O.
Rodless cylinders	1600.HAP	PNP sensor Hall effect with led, normally open N.O.
	1600.HAN	NPN sensor Hall effect with led, normally open N.O.

Technical characteristics

Maximum permanent current	0.5A
Voltage range	10 - 30V DC
Power (inductive load)	10W
Maximum voltage drop	2V
Working temperature	-20°C - 70°C
Cable section	PUR 4.2mm 3x0.34 mm ²
Degree of protection	IP 65
Connecting time	0.8 μ s
Disconnecting time	0.3 μ s
Average working period	10° cycles
Repetition of intervention point	\pm 0.1 mm
Type of contact	N.O.

Diagrams and connections

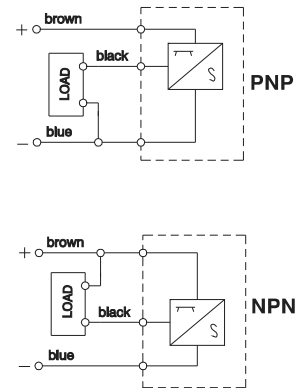

These sensors can be used on cylinders series:

SERIES	DESCRIPTION	MOUNTED
1200	for microbore with threaded end covers and "TECNO-MIR" microbore	with clamps code 1260.Ø.F
	for microbore "MIR" with rolled end covers, cylinders from Ø16 to Ø32	with clamps code 1280.Ø.F
	for microbore "MIR-INOX" with rolled end covers	with clamps code 1280.Ø.FX
1306 - 1307 - 1308	for cylinders from Ø32 to Ø63	with brackets code 1306.A
	for cylinders from Ø80 to Ø125	with brackets code 1306.B
	for cylinders from Ø160 to Ø200	with brackets code 1306.C
1315	for cylinders Ø250 and Ø320 (ISO)	with brackets code 1306.D
1319 - 1320	for cylinders Ø32 and Ø40	with brackets code 1320.A
	for cylinders Ø50 and Ø63	with brackets code 1320.B
	for cylinders Ø80 and Ø100	with brackets code 1320.C
	for cylinders Ø125	with brackets code 1320.D
	for cylinders Ø160	with brackets code 1320.E
	for cylinders Ø200	with brackets code 1320.F
1390 - 1391	for cylinders ECOLIGHT Ø32 and Ø40	with brackets code 1390.A
	for cylinders ECOLIGHT Ø50 and Ø63	with brackets code 1390.B
	for cylinders ECOLIGHT Ø80 and Ø100	with brackets code 1390.C
	for cylinders ECOLIGHT Ø125 - Ø200	with brackets code 1390.D
1500	Compact cylinders "Europe" (from Ø32)	directly on groove

3 PIN sensor for SNAP connector

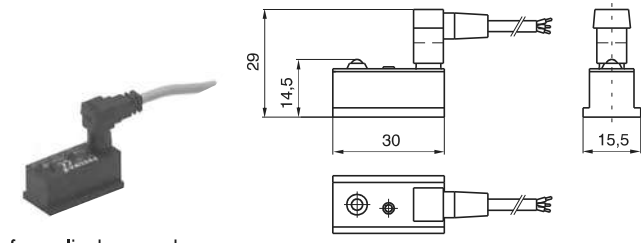

for cylinders and microbore

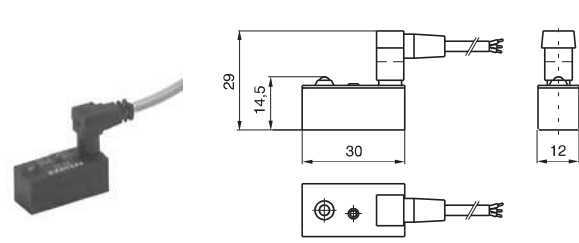
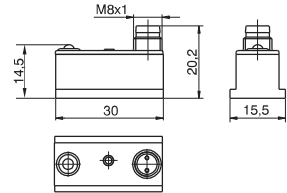
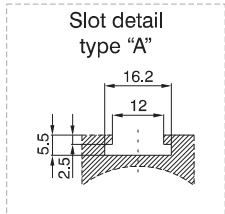

for rodless cylinders

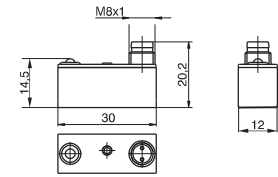

Ordering code

Cylinders and microcylinders	HS.PA	PNP sensor Hall effect with led, normally open N.O.
Rodless cylinders	SHS.PA	PNP sensor Hall effect with led, normally open N.O.
Cable	CH1	connector with 2.5 m. cable 3 wires (PVC Ø3.5 mm 3x0.25 mm ²)
	CH2	connector with 5 m. cable 3 wires (PVC Ø3.5 mm 3x0.25 mm ²)
	CH3	connector with 10 m. cable 3 wires (PVC Ø3.5 mm 3x0.25 mm ²)

3 PIN sensor for SNAP connector + CH1 cable 3 wires (PVC ø3.5 mm 3x0.25 mm²)

Cylinders and microbore	HS.PAC1	PNP sensor Hall effect N.O. with led, with connector and 2.5 m. cable
Rodless cylinders	SHS.PAC1	PNP sensor Hall effect N.O. with led, with connector and 2.5 m. cable

3 PIN sensor for M8 connector

Cylinders and microbore	HS8.NA	NPN Hall effect sensor N.O. with LED and M8 plug
	HS8.PA	PNP Hall effect sensor N.O. with LED and M8 plug
Rodless cylinders	SHS8.NA	NPN Hall effect sensor N.O. with LED and M8 plug
	SHS8.PA	PNP Hall effect sensor N.O. with LED and M8 plug
Cable	MCH1	M8 connector with cable 2.5 m. 3 wires (PUR Ø2.6 mm 3x0.15mm ²)
	MCH2	M8 connector with cable 5 m. 3 wires (PUR Ø2.6 mm 3x0.15mm ²)
	MCH3	M8 connector with cable 10 m. 3 wires (PUR Ø2.6 mm 3x0.15mm ²)

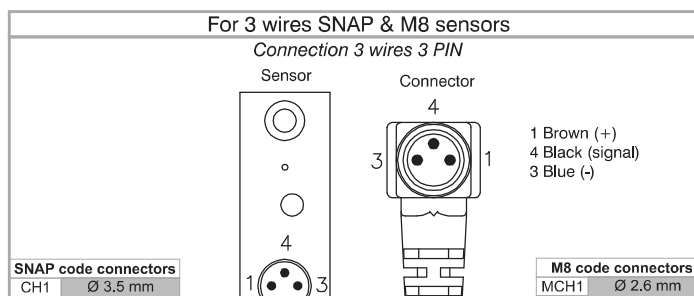



Technical characteristic

Maximum permanent current	0,25A
Voltage range	6 - 30V DC
Power (inductive load)	6W
Maximum Voltage drop	2V
Working temperature	-20°C - 70°C
Cables number	3
Degree of protection	IP 65
Connecting time	0,8 ms
Disconnecting time	0,3 ms
Average working period	10 ⁹ cycles
Repetition of intervention point	± 0,1 mm
Contact normally open	N.O.

Diagrams and connections

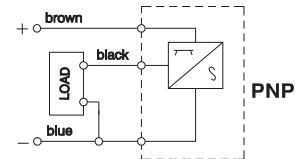
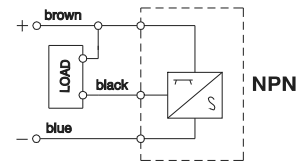

These sensors can be used on cylinders series:

SERIES	DESCRIPTION	MOUNTED
1200	for microbore with threaded end covers and "TECNO-MIR" microbore	with clamps code 1260.Ø.F
	for microbore "MIR" with rolled end covers, cylinders from Ø16 to Ø32	with clamps code 1280.Ø.F
	for microbore "MIR-INOX" with rolled end covers	with clamps code 1280.Ø.FX
1306 - 1307 - 1308	for cylinders from Ø32 to Ø63	with brackets code 1306.A
	for cylinders from Ø80 to Ø125	with brackets code 1306.B
1315	for cylinders from Ø160 to Ø200	with brackets code 1306.C
	for cylinders Ø250 and Ø320 (ISO)	with brackets code 1306.D
1319 - 1320	for cylinders Ø32 and Ø40	with brackets code 1320.A
	for cylinders Ø50 and Ø63	with brackets code 1320.B
	for cylinders Ø80 and Ø100	with brackets code 1320.C
	for cylinders Ø125	with brackets code 1320.D
	for cylinders Ø160	with brackets code 1320.E
	for cylinders Ø200	with brackets code 1320.F
1390 - 1391	for cylinders ECOLIGHT Ø32 and Ø40	with brackets code 1390.A
	for cylinders ECOLIGHT Ø50 and Ø63	with brackets code 1390.B
	for cylinders ECOLIGHT Ø80 and Ø100	with brackets code 1390.C
	for cylinders ECOLIGHT Ø125 - Ø200	with brackets code 1390.D
1500	Compact cylinders "Europe" (from Ø32)	directly on groove
1605	Rodless cylinders	with brackets code 1600.A

