

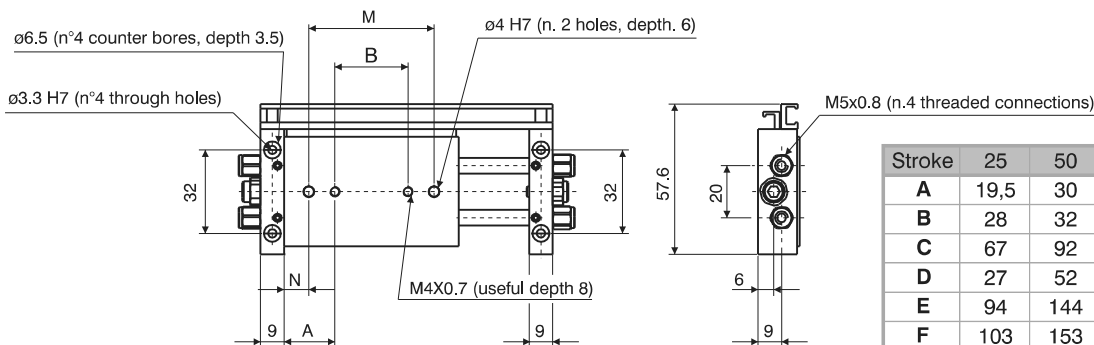

Overall dimensions Ø10

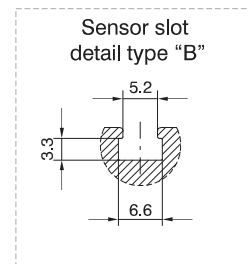
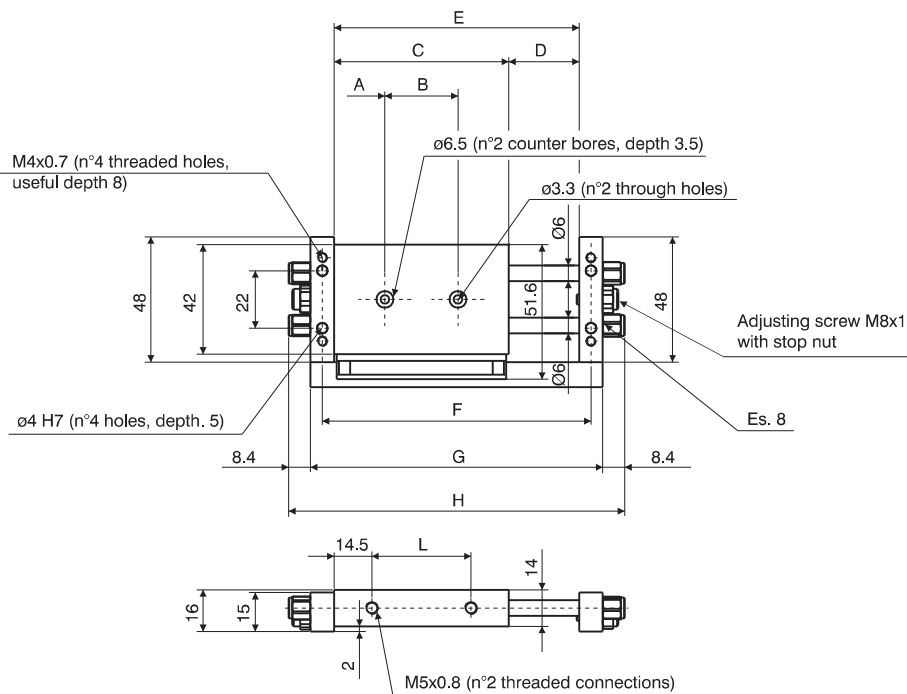

Stroke	25	50	75	100
A	19,5	30	35	35
B	28	32	47	72
C	67	92	117	142
D	27	52	77	102
E	94	144	194	244
F	103	153	203	253
G	112	162	212	262
H	129	179	229	279
L	38	63	88	113
M	48	52	67	92
N	9,5	20	25	25
Weight				
g	160	230	280	310

MOUNTING WITH FIXED PLATE

SENSORS POSITIONING INTO THE BAR
FIXED TO THE EXTERNAL PLATE

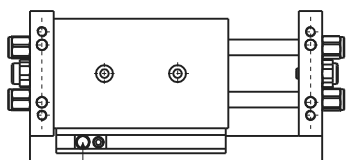
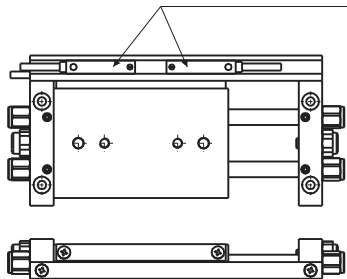

MAGNET POSITIONING INTO THE BAR

MOUNTING WITH A FIXED BODY

MAGNETS POSITIONING INTO THE BAR
FIXED TO THE EXTERNAL PLATE

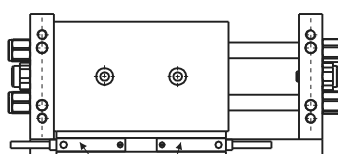
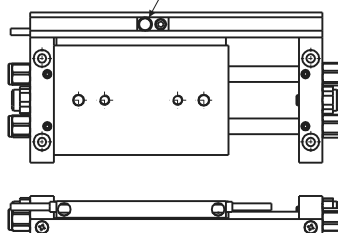

SENSORS POSITIONING INTO THE BAR

MAGNET

SENSOR

SENSOR

MAGNET



Overall dimensions Ø15

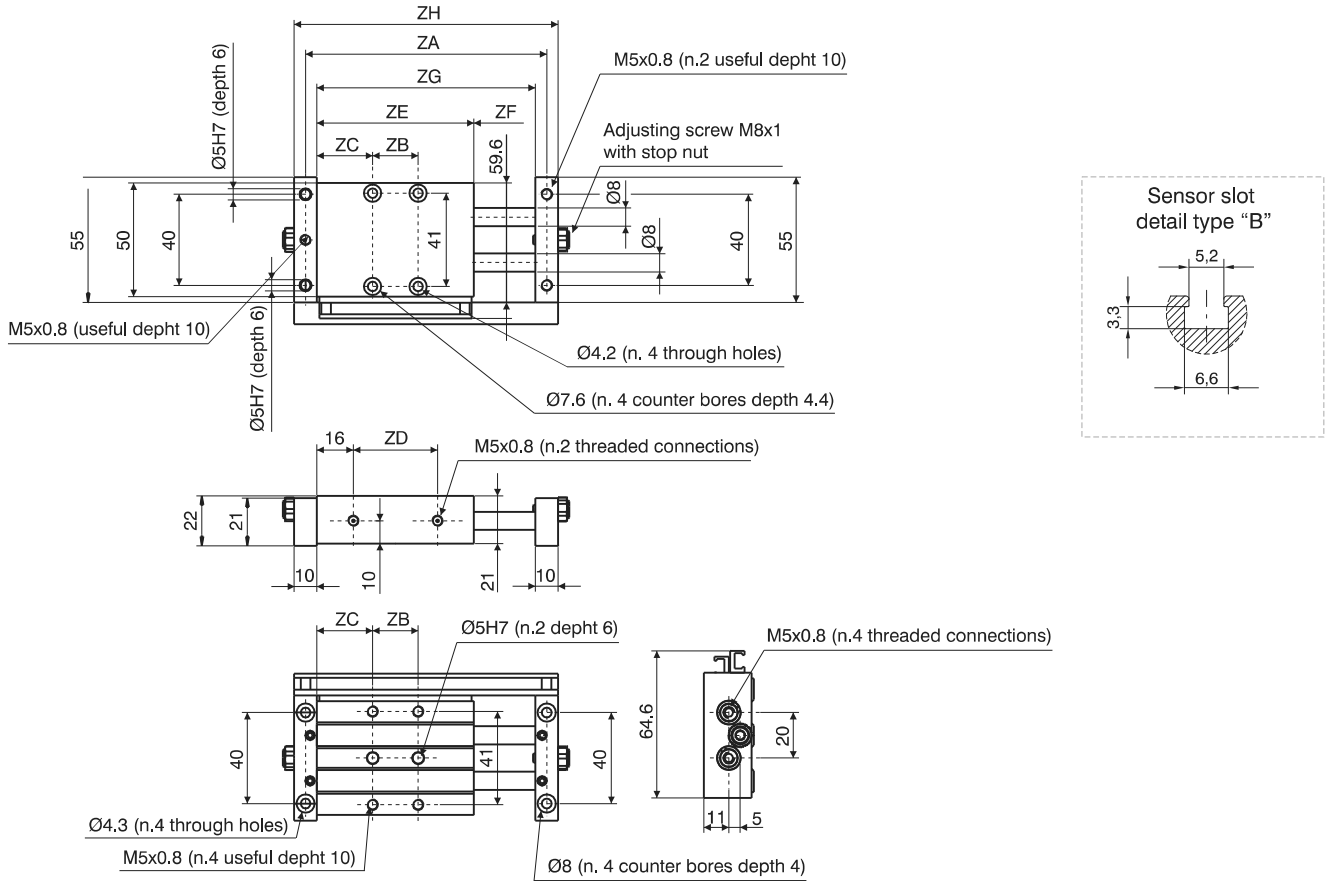

Stroke	25	50	75	100	125	150	175	200
ZA	106	156	206	256	306	356	406	456
ZB	20	45	65	90	90	90	90	90
ZC	24,5	24,5	27	27	39,5	52	64,5	77
ZD	37	62	87	112	137	162	187	212
ZE	69	94	119	144	169	194	219	244
ZF	27	52	77	102	127	152	177	202
ZG	96	146	196	246	296	346	396	446
ZH	116	166	216	266	316	366	416	466
Weight								
g	240	350	450	550	670	750	900	1000

MOUNTING WITH FIXED PLATE

SENSORS POSITIONING INTO THE BAR
FIXED TO THE EXTERNAL PLATE

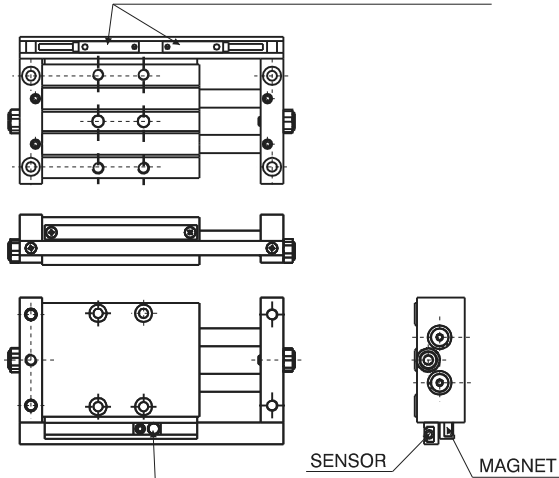

MOUNTING WITH FIXED BODY

SENSORS POSITIONING INTO THE BAR
FIXED TO THE BODY

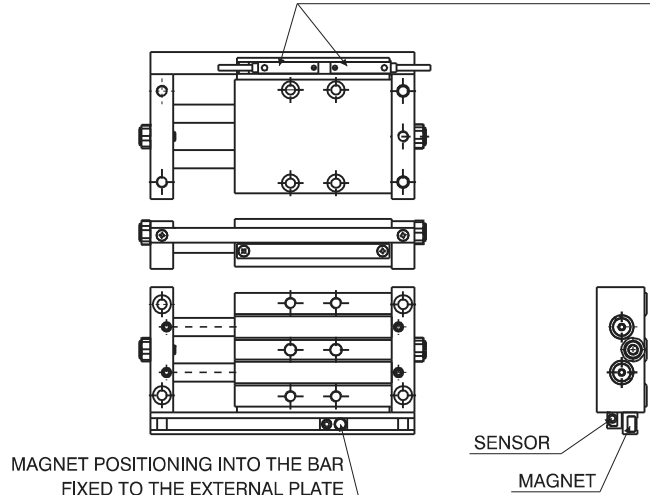

Overall dimensions Ø25

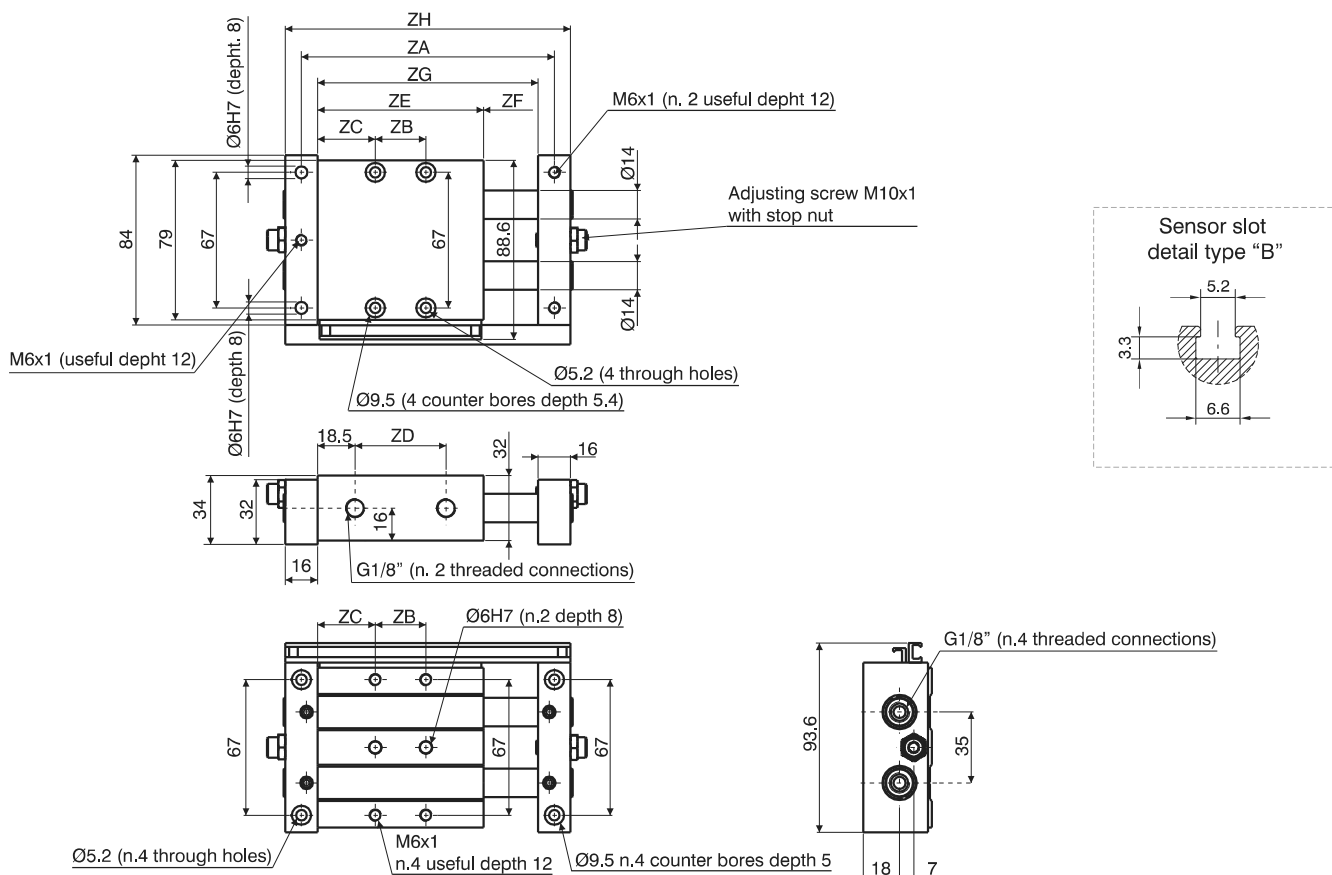

Stroke	25	50	75	100	125	150	175	200
ZA	125	175	225	275	325	375	425	475
ZB	25	45	65	90	90	90	90	90
ZC	28,5	31	33,5	33,5	46	58,5	71	83,5
ZD	45	70	95	120	145	170	195	220
ZE	82	107	132	157	182	207	232	257
ZF	27	52	77	102	127	152	177	202
ZG	109	159	209	259	309	359	409	459
ZH	141	191	241	291	341	391	441	491
Weight								
g	950	1140	1350	1600	1800	2000	2300	2500

MOUNTING WITH FIXED PLATE

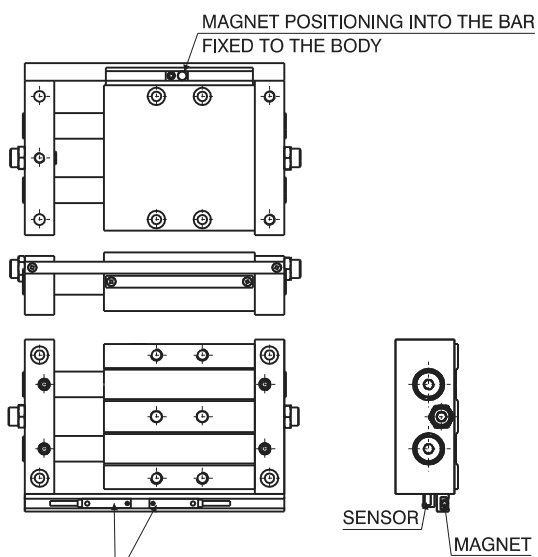

MOUNTING WITH FIXED BODY

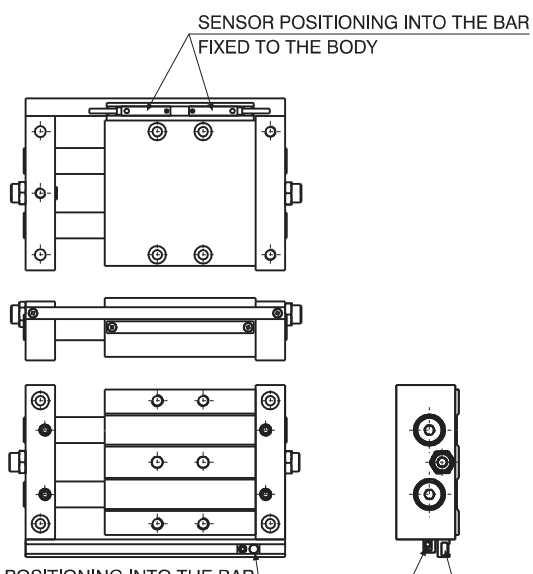



Operating conditions

Theoretical force (N)

Working pressure	Bore		
	Ø10	Ø15	Ø25
2 bar	20	41	119
3 bar	30	62	179
4 bar	40	83	239
5 bar	51	104	299
6 bar	61	124	358
7 bar	71	145	418
8 bar	81	166	478
9 bar	91	186	537
	101	207	597
	Effective area (mm ²)		

Deflection of piston rods

Applied load to body centre

Bore	Load	Deflection (mm)	
Ø10	10 N	0,07	/
Ø15	30 N	0,08	0,28
Ø25	60 N	0,02	0,08
		100	200
		Stroke	

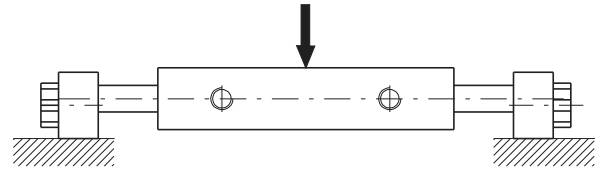

Applied load to body centre

Bore	Load	Deflection (mm)			
Ø10	3 N	0,06	0,3	/	/
Ø15	5 N	0,1	0,2	0,5	1
Ø25	10 N	0,03	0,1	0,15	0,25
		50	100	150	200
		Stroke			

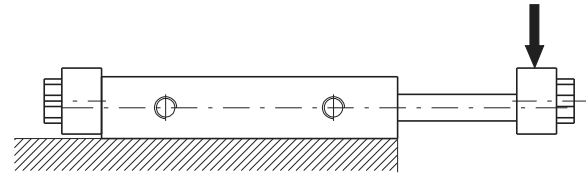

Control unit with bronze bushes

