



Series 1315, Round tube with tie rod cylinders - Ø250 / Ø320

General

Tie rod cylinders, according to standard ISO15552.

Construction characteristics

End caps	aluminium alloy casting
Rod	C43 chromed steel
Barrel	oxidised aluminium
Tie rod	steel with rolled threads
Cushion bushings	aluminium
Rod-guide bushing	sintered bronze
Piston	aluminium
Seals	Standard: NBR oil resistant rubber, PUR piston rod seals

Operational characteristics

Fluid	filtered and lubricated air - hydraulic oil (with special bushing)
Pressure	max. 12 bar
Operating temperature	-5 °C - +70 °C
Cushioning length	50 mm

Please follow the suggestions below to ensure a long life for these cylinders:

- use clean and lubricated air
- correct alignment during assembly with regard to the applied load so as to avoid radial components or bending the rod.
- avoid high speeds together with long strokes and heavy loads: this would produce kinetic energy which the cylinder cannot absorb, especially if used as a limit stop (in this case use mechanical stop device);
- evaluate the environmental characteristics of cylinder used (high temperature, hard atmosphere, dust, humidity etc.)

Please note: air must be dried for applications with lower temperature.

Use hydraulic oils H class (ISO VG32) for correct continued lubrication.

Our Technical Department will be glad to help.

Basic version

Ordering code	
1315.Ø.stroke.01A	
magnetic, aluminium barrel	
BORE	
Ø	250 = 250 mm
	320 = 320 mm

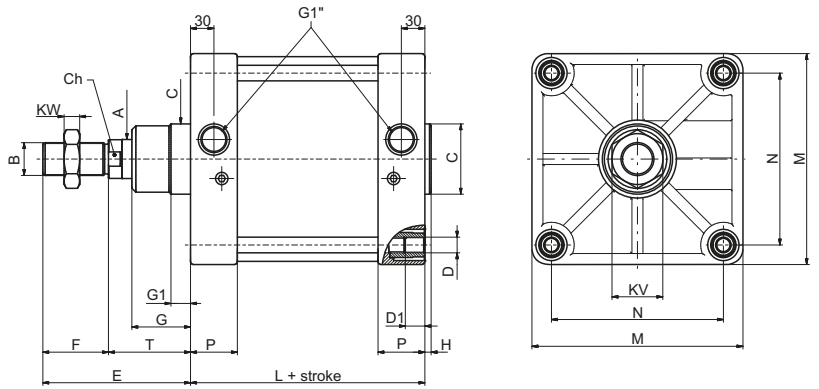

BORE	A	B	Ch	C	D	D1	E	F	G	G1	H	KW	KV	L	M	N	P	T	Weight (g)
250	Ø50	M42x2	46	Ø90	M20	25	189	84	75	25	8	21	Es64	200	270	220	60	105	28.170 (increase of 380 g each 10 mm stroke)
320	Ø63	M48x2	55	Ø110	M24	28	216	96	90	25	10	24	Es72	220	350	270	65	120	49.810 (increase of 616 g each 10 mm stroke)

Table of dimensions

Front and rear flanges

Ordering code	
1315.Ø.03F	
(Steel)	
BORE	
Ø	250 = 250 mm
	320 = 320 mm

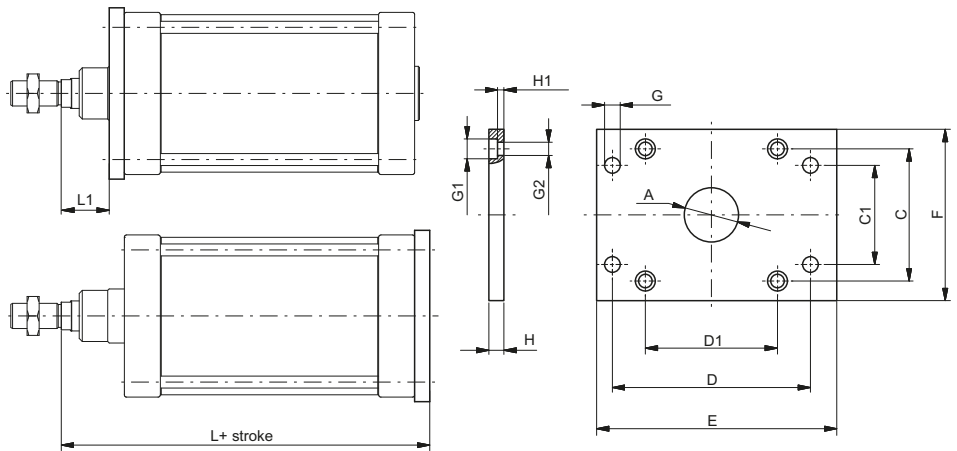

BORE	A(H11)	C	C1 (JS14)	D (JS14)	D1	E	F	G (H13)	G1 (H13)	G2 (H13)	H (±0.2)	H1 (+0, -0.5)	L	L1	Weight (g)
250	90	220	165	330	220	400	285	26	33	22	25	10,5	330	80	20.150
320	110	270	200	400	270	470	350	33	39	26	30	15	370	90	34.000

Table of dimensions

Rear clevis

Ordering code	
1315.Ø.09F	
BORE	
Ø	250 = 250 mm
	320 = 320 mm

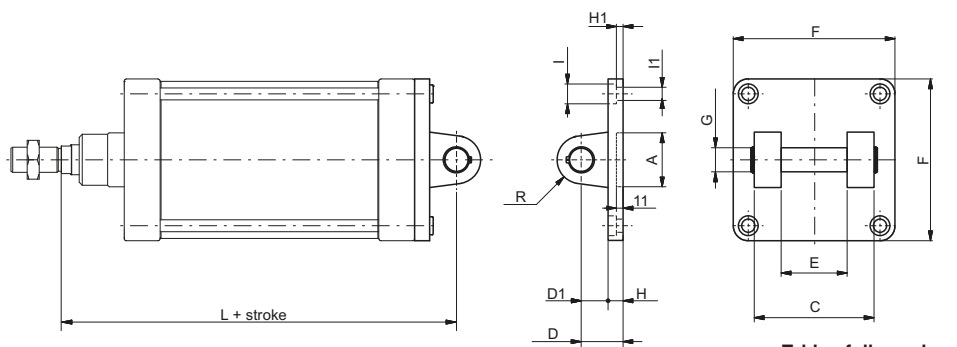

BORE	A	C (h14)	D (±0.2)	D1	E (H14)	F	G (H9)	H	H1	I	I1	L	R	Weight (g)
250	Ø90	200	70	45	110	270	40	25	11	33	22	375	40	7.800
320	Ø110	220	80	50	120	350	42,5	30	15	39	26	420	45	13.000

Table of dimensions

Rear male clevis

Ordering code	
1315.Ø.09/1F	
BORE	
Ø	250 = 250 mm
	320 = 320 mm

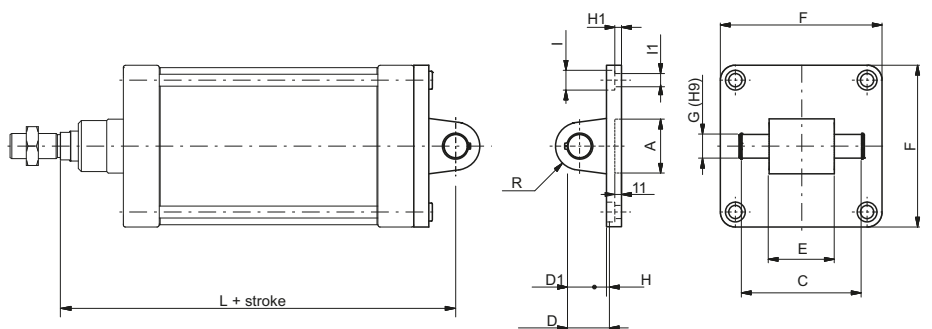

BORE	A	C (+0.3, -0)	D (±0.2)	D1	E (+0.5, -1.2)	F	G (H9)	H	H1	I	I1	L	R	Weight (g)
250	Ø90	202	70	45	110	270	40	25	11	33	22	375	40	8.300
320	Ø110	222	80	50	120	350	42,5	30	15	39	26	420	45	13.060

Table of dimensions