



## Series 1500 - "EUROPE" compact cylinders

### General

This series of cylinders is available in two versions with different threaded fixing holes.

The first one includes cylinders from Ø 32 to Ø 100 called "ISO" with fixing holes same as cylinders ISO 6431 - VDMA 24562. Cylinders from Ø 20 to Ø 100 called "UNITOP", parts of second series, are mainly according to standard UNITOP RU - P/6 - P/7. Cylinders Ø 12 and Ø 16 non standard, are interchangeable with similar products available on the market. The ISO version uses all fixing devices of series 1320 with exception of intermediate trunnion, while for cylinders Ø 12, Ø 16 and for "UNITOP" version are available fixing devices as flanges, foot, male and female clevis made with aluminium or steel. For use of magnetic sensors see directions on next page.

### Construction characteristics

Body	anodised aluminium
End caps	from Ø12 to Ø25 aluminium alloy UNI 9006/1 anodised from Ø32 to Ø100 UNI 5076 aluminium die-casting and painted (cataphoresis)
Piston rod bushing	sintered bronze
Piston rod	from Ø12 to Ø25 stainless steel from Ø32 to Ø100 C43 chromed (on request stainless steel for all bores)
Piston	from Ø12 to Ø25 plated zinc steel from Ø32 to Ø100 aluminium alloy 2011 UNI 9002/5
Seals	PUR (on request HNBR)
Spring	zinc plated steel for springs
Fixing screws	zinc plated steel

### Operational characteristics

Fluid	Filtered air. No lubrication needed, if applied it shall be continuous.
Maximum working pressure	10 bar
Working temperature	-30°C - +80°C with standard seals (magnetic or non magnetic piston) -5°C - +80°C with HNBR seals (magnetic piston) -5°C - +120°C with HNBR seals (non magnetic piston)

Please follow the suggestions below to ensure a long life for these cylinders:

- use clean and lubricated air
- correct alignment during assembly with regard to the applied load so as to avoid radial components or bending the rod.
- avoid high speeds together with long strokes and heavy loads: this would produce kinetic energy which the cylinder cannot absorb, especially if used as a limit stop (in this case use mechanical stop device)
- evaluate the environmental characteristics of cylinder used (high temperature, hard atmosphere, dust, humidity etc.)

**Please note: air must be dried for applications with lower temperature.**

Use hydraulic oils H class (ISO VG32) for correct continued lubrication.

Our Technical Department will be glad to help.

### Standard strokes for single acting cylinders

Ø12	10 mm max.
from Ø16 to Ø100	25 mm max.

### Maximum suggested strokes

Ø12 and Ø16	100 mm
Ø20 and Ø25	200 mm
Ø32 and Ø40	300 mm
Ø50 and Ø63	400 mm
Ø80 and Ø100	500 mm

*Longer strokes may be utilised if there is no radial loads on piston rod considering there isn't adjustable cushioning system*

### Standard strokes for double acting cylinders

Ø12 and Ø16	from 5 to 40mm every 5mm
Ø20 and Ø25	from 5 to 50mm every 5mm
Ø32 - Ø100	from 5 to 80mm every 5mm

### Maximum suggested strokes with non-rotating device

from Ø12 to Ø25	40 mm
from Ø32 to Ø100	80 mm

### Minimum and maximum springs load

Bore	12	16	20	25	32	40	50	63	80	100
Min. load (N)	3,9	4,4	4,9	9,8	12,3	16,7	27,5	37,3	59,4	101,3

► BASIC version double and single acting



for bores from Ø 12 to Ø 25  
use sensors codes  
1580.\_, MHS.\_, MRS.\_ only

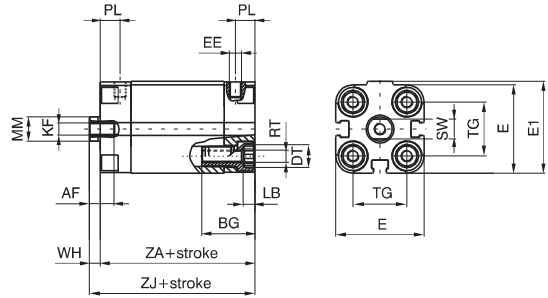
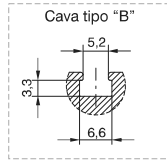

for bores from Ø 32 to Ø 50  
use sensors codes  
1500.\_, RS.\_, HS.\_ (slot A)  
1580.\_, MHS.\_, MRS.\_  
(slot B and slot A with adapter code 1380.01F)

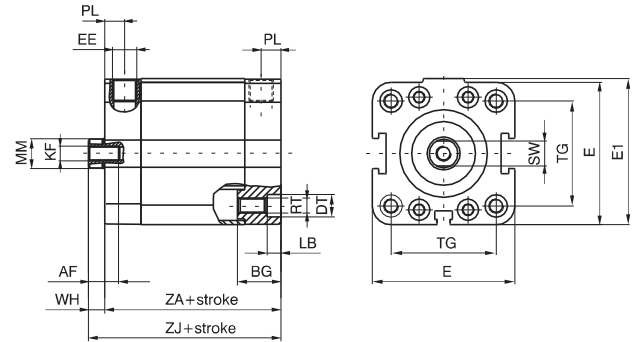
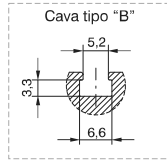
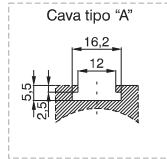

for bores from Ø 63 to Ø 100  
use sensors codes  
1500.\_, RS.\_, HS.\_ and  
1580.\_, MHS.\_, MRS.\_  
(with adapter code 1380.01F)

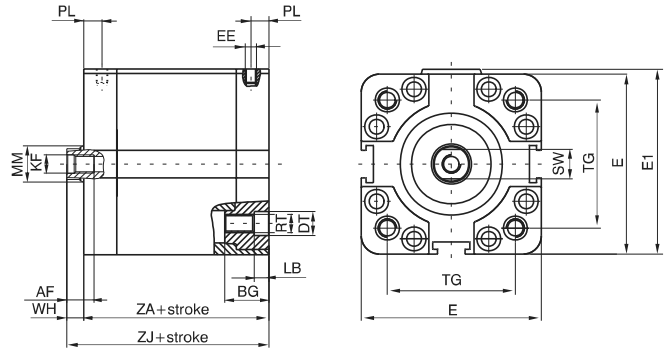
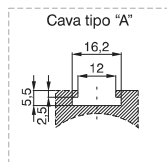

3

PNEUMATIC ACTUATION

► Through rod cylinder version double and single acting

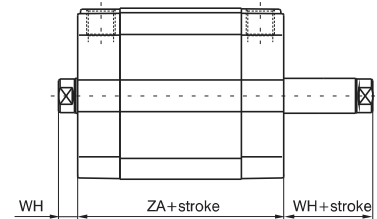

► Tandem with opposite rods

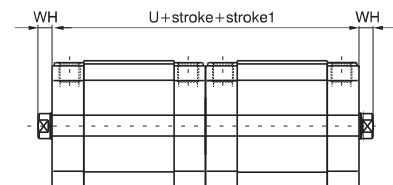

► Tandem push with common rods

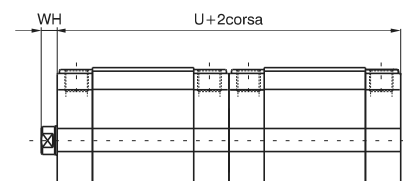



▶ **Opposed tandem with common rod**

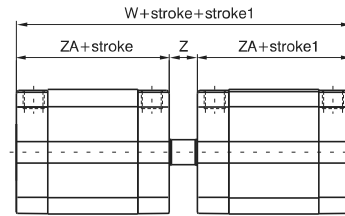

▶ **Tandem push with independent rods**

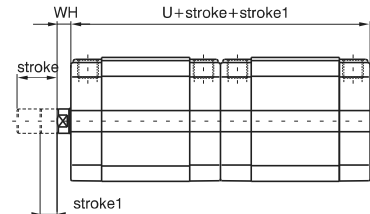

**Ordering code**

**Basic version, through rod cylinder**

- 15 . Ø . stroke . . . . .
- 1 = Double acting (magnetic)
  - 2 = Front spring (magnetic)
  - 3 = Rear spring (magnetic)
  - 4 = Double acting (non magnetic)
  - 5 = Front spring (non magnetic)
  - 6 = Rear spring (non magnetic)
- 01 = Basic version - female piston rod  
 02 = Basic version - male piston rod  
 03 = Through rod version - female piston rod  
 04 = Through rod version - male piston rod  
 05 = Through rod version - bored male piston rod  
 06 = Through rod version - bored female piston rod  
 07 = Non - rotating version  
 08 = Through rod version with non rotating device on one side - female piston rod \*
- 09 = Through rod version with non rotating device on one side - male piston rod \*
- 1 = Chromed rod C43 (from Ø12 to Ø25 stainless steel)  
 2 = Stainless steel rod (from Ø32 to Ø100)
- 6 = ISO (Ø32 - Ø100)  
 7 = ISO HNBR (Ø32 - Ø100)  
 8 = UNITOP (Ø12 - Ø100)  
 9 = UNITOP HNBR (Ø12 - Ø100)
- \* for single acting version, the spring is on the anti-rotation side

**Tandem version**

- 15 . Ø . stroke .(stroke1) . . . . .
- A = Tandem with opposite rods female thread
  - E = Tandem with opposite rods male thread
  - L = Tandem opposite rods with non rotating device on both sides
  - C = Tandem push with common rods female thread
  - G = Tandem push with common rods male thread
  - H = Tandem push with common rods, push-pull version rod female threads
  - N = Tandem push with common rods with non rotating device
  - D = Opposed tandem with common rod
  - B = Tandem push with independent rods female thread
  - F = Tandem push with independent rods male thread
  - M = Tandem push with independent rods with non rotating device
  - P = Tandem through rod with independent rods - female thread
  - Q = Tandem through rod with independent rods - male thread
- 1 = Chromed rod C43 (from Ø12 to Ø25 stainless steel)  
 2 = Stainless steel rod (from Ø32 to Ø100)
- 6 = ISO (Ø32 - Ø100)  
 7 = ISO HNBR (Ø32 - Ø100)  
 8 = UNITOP (Ø12 - Ø100)  
 9 = UNITOP HNBR (Ø12 - Ø100)

**Table of dimensions**

Bore	12	16	20	25	32	40	50	63	80	100	
AF	6	8	10	10	12	12	12	12	16	20	
BG	19	19	20	20	17,5	17,5	19,5	19,5	23,5	24,5	
DT	6	6	8	8	10	9	10,5	10,5	14	14	
E	29	29	36	40	48	57	67	80	102	122	
E1	30	30	37,5	41,5	49,5	58,5	69	82	105	125	
EE	M 5	M 5	M 5	M 5	G 1/8"	G 1/8"	G 1/8"	G 1/8"	G 1/8"	G 1/4"	
KF	M 3	M 4	M 5	M 5	M 6	M 6	M 8	M 8	M 10	M 12	
LB	3,5	3,5	4,8	4,8	5,5	5,5	6,5	6,5	8,5	8,5	
MM	6	8	10	10	12	12	16	16	20	25	
PL	8	8	8	8	8	8	8	8	8,5	10,5	
RT	M 4	M 4	M 5	M 5	M 6	M 6	M 8	M 8	M 10	M 10	
SW	5	7	8	8	10	10	13	13	17	22	
TG ISO	/	/	/	/	32,5	38	46,5	56,5	72	89	
TG UNITOP	18	18	22	26	32	42	50	62	82	103	
U	76	76	76	79	89	91	91	100	112	133	
W	85	85	85	90	101	104	106	115	128	153	
WH	4,5	4,5	4,5	5,5	6	6,5	7,5	7,5	8	10	
Z	9	9	9	11	12	13	15	15	16	20	
ZA *	38	38	38	39,5	44,5	45,5	45,5	50	56	66,5	
ZJ *	42,5	42,5	42,5	45	50,5	52	53	57,5	64	76,5	
Weight	stroke 0	88	90	140	170	210	320	460	690	1390	2290
g	every 5 mm	8	8	12	13	15	19	25	31	50	66

► Basic version male piston rod

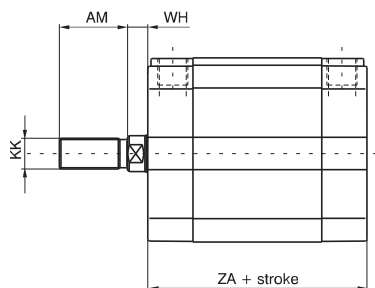

► Through rod cylinder version, male rod

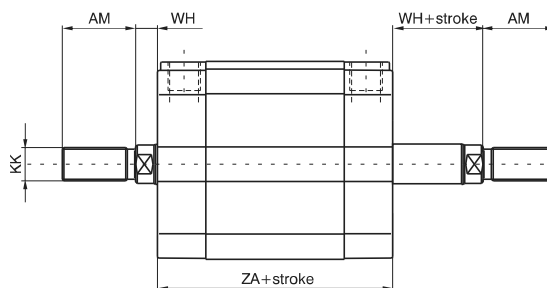

► Through rod cylinder version, bored male piston rod

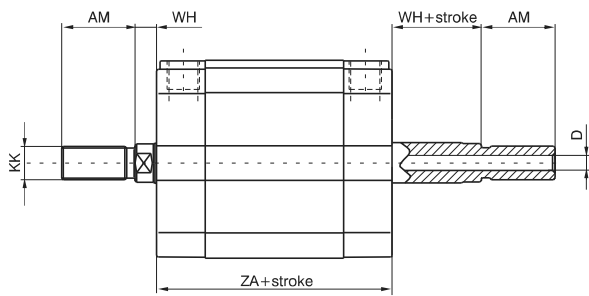

► Through rod cylinder version, bored female piston rod

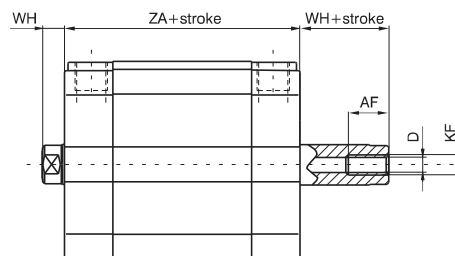

Maximum allowed stroke = ZB (see table)

► Non-rotating version

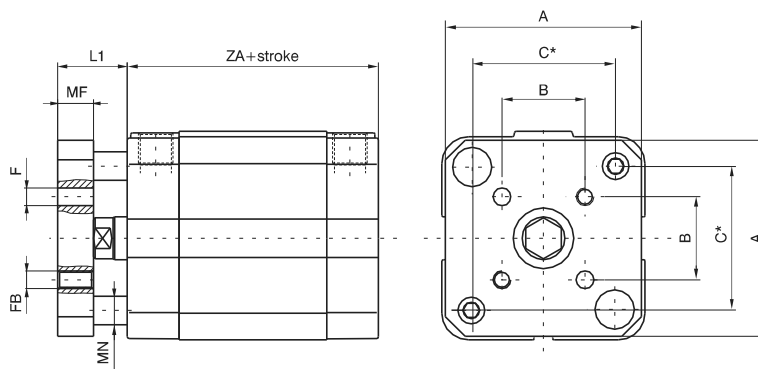

\* = Distance between rods centres

Bore	12	16	20	25	32	40	50	63	80	100
A	28,5	28,5	35,5	39,5	45	55	65	80	100	120
AF	6	8	10	10	12	12	12	12	16	20
AM	16	20	22	22	22	22	24	24	32	40
B	9,9	9,9	12	15,6	19,8	23,3	29,7	35,4	46	56,6
C	18	18	22	26	34	40,5	49	59,5	77	94
D	2,3	3,2	3,8	3,8	4,5	4,5	6	6	8	10
F	3	3	4	5	5	5	6	6	8	10
FB	M 3	M 3	M 4	M 5	M 5	M 5	M 6	M 6	M 8	M 10
KF	M 3	M 4	M 5	M 5	M 6	M 6	M 8	M 8	M 10	M 12
KK	M6X1	M8X1,25	M10X1,25	M10X1,25	M10X1,25	M10X1,25	M12X1,25	M12X1,25	M16X1,5	M20X1,5
L1	10,5	10,5	12,5	13,5	16	16,5	19,5	19,5	22	24
MF	6	6	8	8	10	10	12	12	14	14
MN	5	5	6	6	8	8	10	10	12	12
WH	4,5	4,5	4,5	5,5	6	6,5	7,5	7,5	8	10



**Front and rear flanges**

Ordering code

ISO  
**1500.Ø.03F**  
steel

UNITOP  
**1580.Ø.03F**  
steel

**1580.Ø.03/1F**  
aluminium

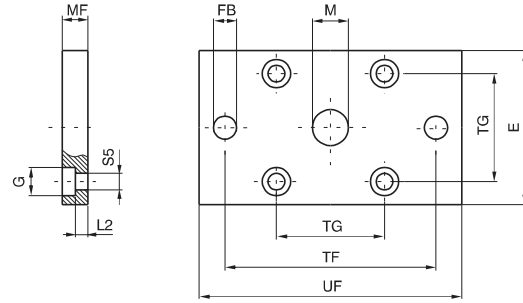

For bores from 12 to 25

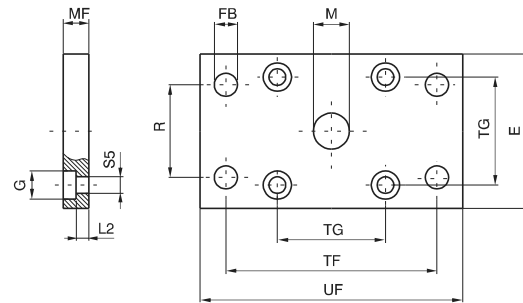

For bores from 32 to 100

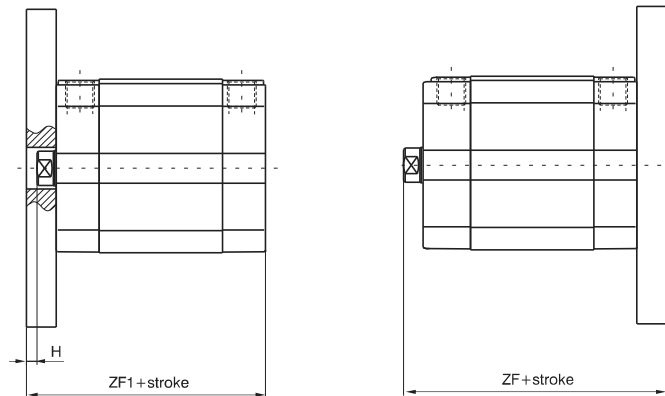

Front

Rear

Plate which allows anchorage of the cylinder at a right angle to the plane. It is made with zinc-plated extruded steel or with aluminium.

	ISO Dimensions						UNITOP Dimensions									
	32	40	50	63	80	100	12-16	20	25	32	40	50	63	80	100	
Bore	32	40	50	63	80	100	12-16	20	25	32	40	50	63	80	100	
E	45	52	65	75	95	115	29	36	40	50	60	68	87	107	128	
S5 (H13)	6,6	6,6	9	9	11	11	4,5	5,5	5,5	6,6	6,6	9	9	11	11	
FB(H13)	7	9	9	9	12	14	5,5	6,6	6,6	7	9	9	9	12	14	
G	10,5	11	15	15	18	18	9	10	10	11	11	15	15	18	18	
H	4	3,5	4,5	4,5	8	6	5,5	5,5	4,5	4	3,5	4,5	7,5	7	5	
L2	5	5	6,5	6,5	8	8	4,6	4,6	4,6	3,6	3,6	3,4	6,4	4,4	4,4	
M(H11)	30	35	40	45	45	55	10	12	12	14	14	18	18	23	28	
MF(JS14)	10	10	12	12	16	16	10	10	10	10	10	12	15	15	15	
R(JS14)	32	36	45	50	63	75	/	/	/	32	36	45	50	63	75	
TF(JS14)	64	72	90	100	126	150	43	55	60	65	82	90	110	135	163	
TG	32,5	38	46,5	56,5	72	89	18	22	26	32	42	50	62	82	103	
UF	80	90	110	120	150	170	55,5	70	76	80	102	110	130	160	190	
ZF	60,5	62	65	69,5	80	92,5	52,5	52,5	55	60,5	62	65	72,5	79	91,5	
ZF1	54,5	55,5	57,5	62	72	82,5	48	48	49,5	54,5	55,5	57,5	65	71	81,5	



► Foot

Ordering code
<i>ISO</i>
<b>1500.Ø.05/1F</b>
(1 piece)
<i>UNITOP</i>
<b>1580.Ø.05/1F</b>
(1 piece)

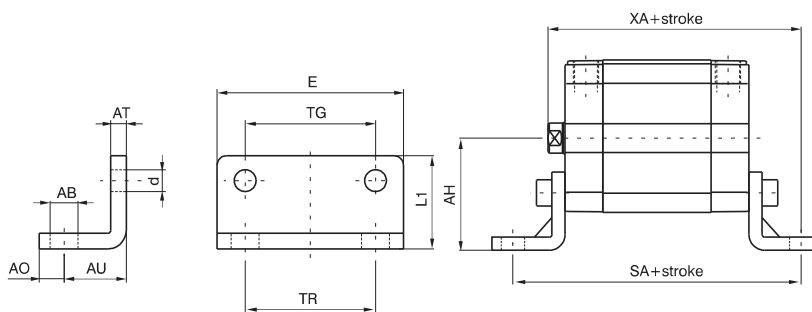

Element used to anchor the cylinder parallel to the mounting plane. They are made with stamped and pierced sheet metal black painted.

	ISO Dimensions						UNITOP Dimensions									
Bore	32	40	50	63	80	100	12-16	20	25	32	40	50	63	80	100	
AB (H14)	7	9	9	9	12	14	5,5	6,6	6,6	6,6	9	9	11	11	13,5	
AH (JS15)	32	36	45	50	63	71	22	27	30	32	42,5	47	59,5	65,5	78	
AO (±0,2)	11	8	15	13	14	16	4,5	6	6	8	8	8	12	12	12	
AT	4	4	5	5	6	6	3	4	4	5	5	6	6	8	8	
AU (±0,2)	24	28	32	32	41	41	13	16	16	18	20	24	27	30	33	
d	7	7	9	9	11	11	4,4	5,4	5,4	6,6	6,6	9	9	11	11	
E	45	52	65	75	95	115	30	36	40	50	60	68	84	102	123	
L1	30	30	36	35	47	53	17,5	22	23	24	29,5	30	39	36,5	38,5	
SA	92,5	101,5	109,5	114	138	148,5	64	70	71,5	80,5	85,5	93,5	104	116	132,5	
TG	32,5	38	46,5	56,5	72	89	18	22	26	32	42	50	62	82	103	
TR	32	36	45	50	63	75	18	22	26	32	42	50	62	82	103	
XA	74,5	80	85	89,5	105	117,5	55,5	58,5	61	68,5	72	77	84,5	94	109,5	
Weight g	50	70	120	180	320	400	20	35	45	75	100	150	250	390	500	

3

PNEUMATIC ACTUATION

► UNITOP rear male clevis for bores from 12 to 25

Ordering code
<b>1580.Ø.09/1F (Aluminium)</b>
<b>1580.Ø.09/2F (Steel)</b>

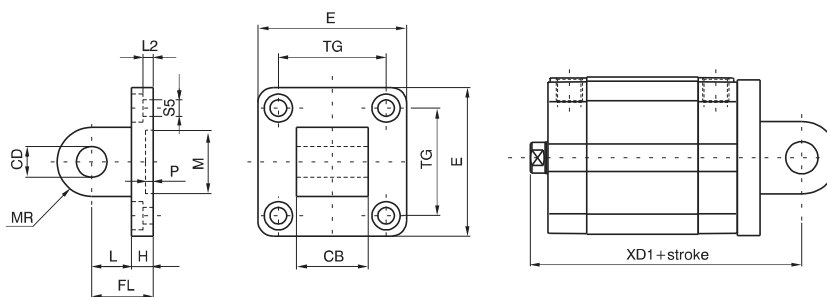

This type of mounting allows anchorage of the cylinder both parallel and at the right angle to the plane. The cylinder rod can oscillate and self-align to the connected load. It's made with aluminium alloy black painted or with zinc plated steel (from Ø 20).

Bore	12-16	20	25
CB(h14)	12	16	16
CD (H9)	6	8	8
E (±0,5)	27	34	38
FL	16	20	20
H	6	6	6
L	10	14	14
L2 (±0,5)	2,6	2,6	2,6
M (H11)	10	12	12
MR	6	8	8
P (+0,3)	3	3	3
S5 (H13)	4,5	5,5	5,5
TG (±0,2)	18	22	26
XD1	58,5	62,5	65



**Front female clevis for bores from 32 to 100**

Ordering code

ISO  
Aluminium  
**1500.Ø.08F**

UNITOP (Aluminium)  
**1580.Ø.11F**

UNITOP (Steel)  
**1580.Ø.13F**

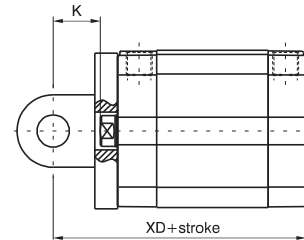
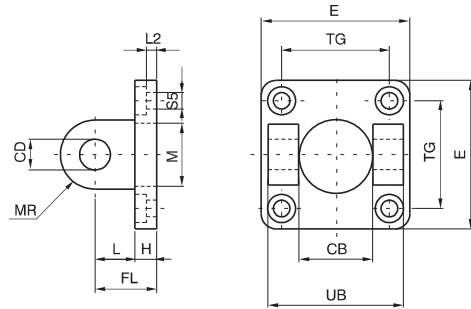

This type of mounting allows anchorage of the cylinder both parallel and at the right angle to the plane. The cylinder rod can oscillate and self-align to the connected load. It's made with aluminium alloy black painted or with zinc plated steel.

3 PNEUMATIC ACTUATION

**Rear female clevis for bores from 32 to 100**

Ordering code

ISO  
Aluminium  
**1500.Ø.09F**

UNITOP (Aluminium)  
**1580.Ø.10F**

UNITOP (Steel)  
**1580.Ø.12F**

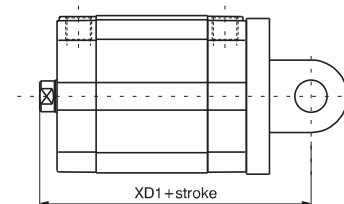
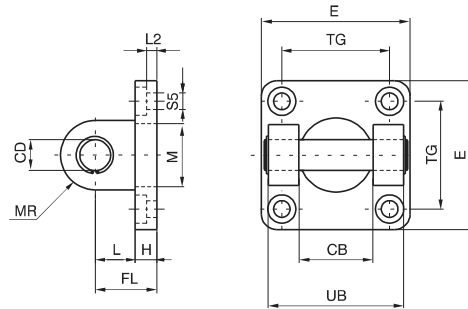

This type of mounting allows anchorage of the cylinder both parallel and at the right angle to the plane. The cylinder rod can oscillate and self-align to the connected load. It's made with aluminium alloy black painted or with zinc plated steel.

		ISO Dimensions						UNITOP Dimensions					
Bore		32	40	50	63	80	100	32	40	50	63	80	100
CB (H14)		26	28	32	40	50	60	26	28	32	40	50	60
CD (H9)		10	12	12	16	16	20	10	12	12	16	16	20
E		45	52	65	75	95	115	48	58	66	83	102	123
FL		22	25	27	32	36	41	22	25	27	32	36	41
H		9	9	11	11	14	14	9	9	11	11	13	15
K		16	18,5	19,5	24,5	28	31	16	18,5	19,5	24,5	28	31
L		13	16	16	21	22	27	13	16	16	21	23	26
L2		5,5	5,5	6,5	6,5	10	10	5,5	5,5	6,5	6,5	10	10
M		30	35	40	45	45	55	14	14	18	18	23	28
MR		10	12	12	16	16	20	10	12,5	12,5	15	15	20
S5		6,6	6,6	9	9	11	11	6,6	6,6	9	9	11	11
TG		32,5	38	46,5	56,5	72	89	32	42	50	62	82	103
UB		45	52	60	70	90	110	45	52	60	70	90	110
XD		66,5	70,5	72,5	82	92	107,5	66,5	70,5	72,5	82	92	107,5
XD1		72,5	77	80	89,5	100	117,5	72,5	77	80	89,5	100	117,5
Weight g	Steel												
	Front	/	/	/	/	/	/	180	310	420	700	1240	2210
	Rear	/	/	/	/	/	/	220	360	480	830	1390	2500



► Slot fixing screws

Ordering code
<b>1500.17F</b> small slot (from Ø12 to Ø50)
<b>1500.15F</b> large slot (Ø32)
<b>1500.16F</b> large slot (from Ø40 to Ø63)
<b>1500.18F</b> large slot (from Ø80 to Ø100)

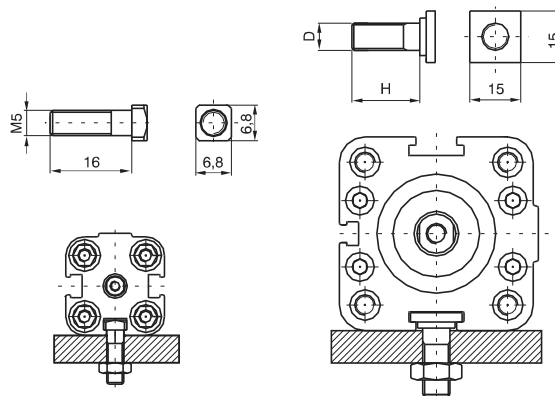
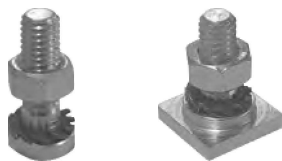

Example of mounting with square head screws

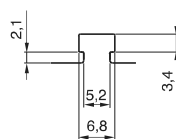

Small slot detail

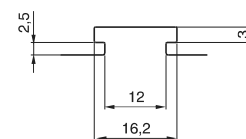

Large slot detail

Bore	12÷50	32	40÷63	80÷100
D	/	M6	M8	M10
H	/	15	20	25
Weight g	8	10	18	25

► Centering rings

Ordering code
<b>1580.Ø.02F</b>

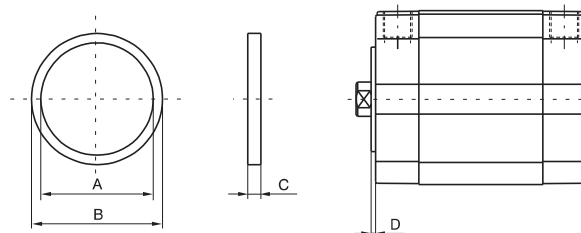

This aluminium ring allows the center assembling of the cylinder.

Bore	32	40	50	63	80	100
A	25	30	35	40	40	50
B (e11)	30	35	40	45	45	55
C	3,5	3,5	3,5	4,5	5,5	5,5
D	1,5	1,5	1,5	2	2,5	2,5
Weight g	2	2	3	4	5	6

► Sensor adapter

Ordering code
<b>1380.01F</b>



Weight g 2

