

LIMAX22 DUE

Magnetic-redundant Absolute Shaft Information System

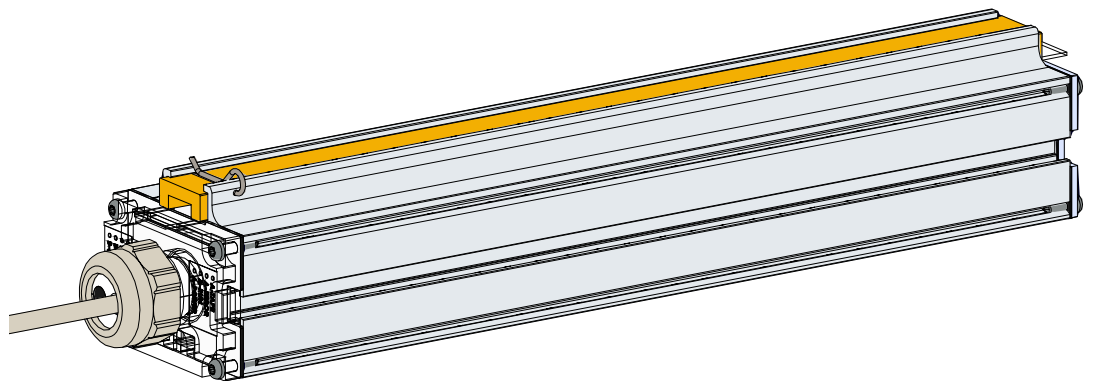

- Redundant version with Dual Sensor
- Absolute measurement for hoisting heights up to 260 m
- Resolutions: 62,5 / 125 / 250 / 500 or 1000 μm
- Very robust against dust, dirt and smoke
- Travel speed up to 10 m/s
- With Basic CAN interface (others on request)
- No referencing necessary
- Easy and flexible to install
- Vertical installation of the magnetic tape
- Wear-free, contactless and noiseless measuring principle

LIMAX22 DUE - Magnetic-redundant Absolute Shaft Information System

General:

LIMAX22 DUE is an absolute magnetic measuring system that offers redundant detection of the car's absolute position in the elevator shaft.

The sensor housing contains two mutually independent sensors with the same function. The functionality of both sensors is recorded and monitored by the elevator system's master control.

With this technology safety is doubled in such a manner that, in case of failure of one sensor, the other sensor is able to ensure continued operation of the elevator.

LIMAX22 DUE is able to cover lifting heights up to 260 meters and speeds up to 10 m/s. A simple and flexible mounting ensures quick installation or replacement of the measuring system.

Position Measurement:

For measurement of the lift position, the dual-sensor which is integrated in aluminum profile housing requires an absolute coded magnetic tape (type **AB20-80-10-1-R-D-15-BK80**), which carries the unique position information as a magnetic code. The magnetic tape is mounted free-hanging in the shaft by using an ELGO mounting set (see accessories on the last page). At the lower end, the tape is tensioned while it is guided along the cabin by a plastic guide on the sensor. The actual measurement resp. scanning is basically contactless. The guidance merely serves to keep the correct distance to the sensor.

Resolution:

Depending on the requirements, an appropriate system resolution can be defined with the order (see type designation). The available standard resolutions are 62.5 / 125 / 250 / 500 and 1000 μm .

Interface:

For communication with the lift control, a CAN basic interface is standardly used which can optionally be terminated with 120R load resistors (see type designation "T"). Other interfaces as well as customer-specific protocols or CAN device profiles are optionally available on request.

Status LEDs:

The LIMAX22 DUE housing front has for each integrated sensor four separate status LEDs which serve for various messages, e. g. operational readiness or error states of the system, magnetic tape and interface.

Connections:

By default the LIMAX2 DUE encoder is supplied with a 3 meter long signal cable with open cable ends. Optionally the signal cable can be delivered as plugin version with a RJ45 network cable connector (option RJ45).

Sensor Installation:

In order to mount the sensor to the lift cabin, the mounting angle kit **LIMAX2 MW SET** can be used, which is available as an ELGO accessory. This mounting kit includes also the required screws with sliding nuts which can be inserted into the mounting groove of the sensor housing in order to fix the angle to the sensor housing.

With the remaining long holes, the unit can be fastened on the cabin roof. The tape guidance at the sensor permanently ensures the correct distance between magnetic tape and sensor.

Magnetic Tape Installation:

For elevator applications, the magnetic tape is attached free hanging to the upper end of the shaft and is tensioned at the lower end of the shaft by using a tension spring. Several mounting sets are available for the tape installation, which contain different components depending on the respective requirements.

All variants and their order designations are summarized in the table "Accessories" on the last page. Available are various mounting sets as well for central guided cabins as for rucksack-guided systems.

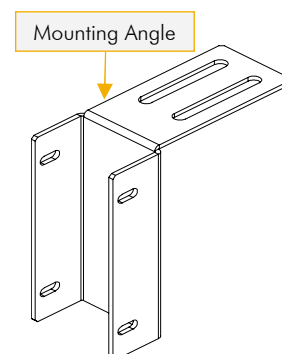

LIMAX22 DUE - Magnetic-redundant Absolute Shaft Information System

Technical Data:

| Mechanical Data | |
|-------------------------------------------|--------------------------------------------------------------|
| Measuring principle | absolute, redundant |
| Repeat accuracy | ± 1 increment |
| System accuracy in μm at 20 °C | ± (1000 + 100 x L) L = measuring length in meters |
| Distance sensor / tape | the correct distance is guaranteed by guidance |
| Housing material | aluminium |
| Housing dimensions | L x W x H = 290 x 55 x 55 mm |
| Required magnetic tape | AB20-80-10-1-R-D-15-BK80 |
| Basic pole pitch (tape) | 8 mm |
| Max. measuring length | 260 m |
| Connections | standard: open cable ends optional: RJ45 connector |
| Sensor cable | standard length: 3.0 m optional: 5.0 m, others on request |
| Weight | approx. 550 g without cable cable: approx. 60 g per meter |

Electrical Data

| | |
|----------------------|---------------------------------------------------------------|
| Power supply voltage | 10 ... 30 VDC |
| Residual ripple | <10 % |
| Current consumption | max. 200 mA |
| Interface | CAN basic, others on request |
| Resolution | 1.0 (standard) or 0.5 / 0.25 / 0.125 / 0.0625 mm (optionally) |
| Operating speed | max. 10 m/s |

Environmental conditions

| | |
|-----------------------|-----------------------------------------------|
| Storage temperature | -25 ... +85 °C |
| Operating temperature | -10 ... +70 °C (-25 ... +85 °C on request) |
| Humidity | 95 %, non-condensing |
| Protection class | IP50 |

Top view LIMAX2 MW mounting angle set:

(Dimensions of the long holes for mounting on the cabin roof)

8.40 X 63.40

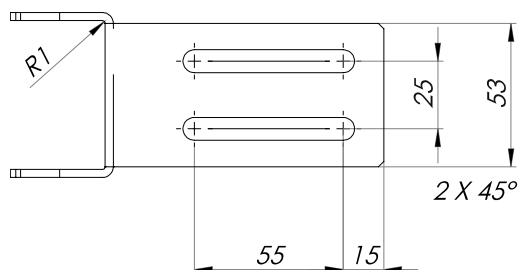

Type Designation:

LIMAX2D - $\frac{\text{A}}{\text{A}}$ - $\frac{\text{B}}{\text{B}}$ - $\frac{\text{C}}{\text{C}}$ - $\frac{\text{D}}{\text{D}}$ - $\frac{\text{E}}{\text{E}}$

A Version

- 00 = ELGO standard
- 01 = First special version (etc.)

B Signal Cable Length

- 030 = 3.0 m (standard)
- 050 = 5.0 m (other lengths on request)

C Resolution

- 62N5 = 62.5 μm (0.0625 mm)
- 0125 = 125 μm (0.125 mm)
- 0250 = 250 μm (0.25 mm)
- 0500 = 500 μm (0.5 mm)
- 1000 = 1000 μm (1 mm)

D Interface

- CN0 = CAN [standard protocol Basic-CAN] not terminated
- CN0T = CAN [standard protocol Basic-CAN] terminated by 120R*

*) CAUTION:

CAN interface is optionally available with galvanic isolation / Assembly with CAN terminating resistor 120R selectable (T)

E Connection Option

- RJ45 = RJ45 network cable connector
- Other connectors on request

Order example:

LIMAX2D - 00 - 030 - 10 0 0 - CN0T - RJ45
AA - BBB - CCCC - DDDD - EEEE

ELGO standard LIMAX22 DUE with 3 m cable, 1 mm resolution, CAN basic interface (terminated, 120R) and RJ45 connector



LIMAX22 DUE

Dimensions of LIMAX22 DUE:

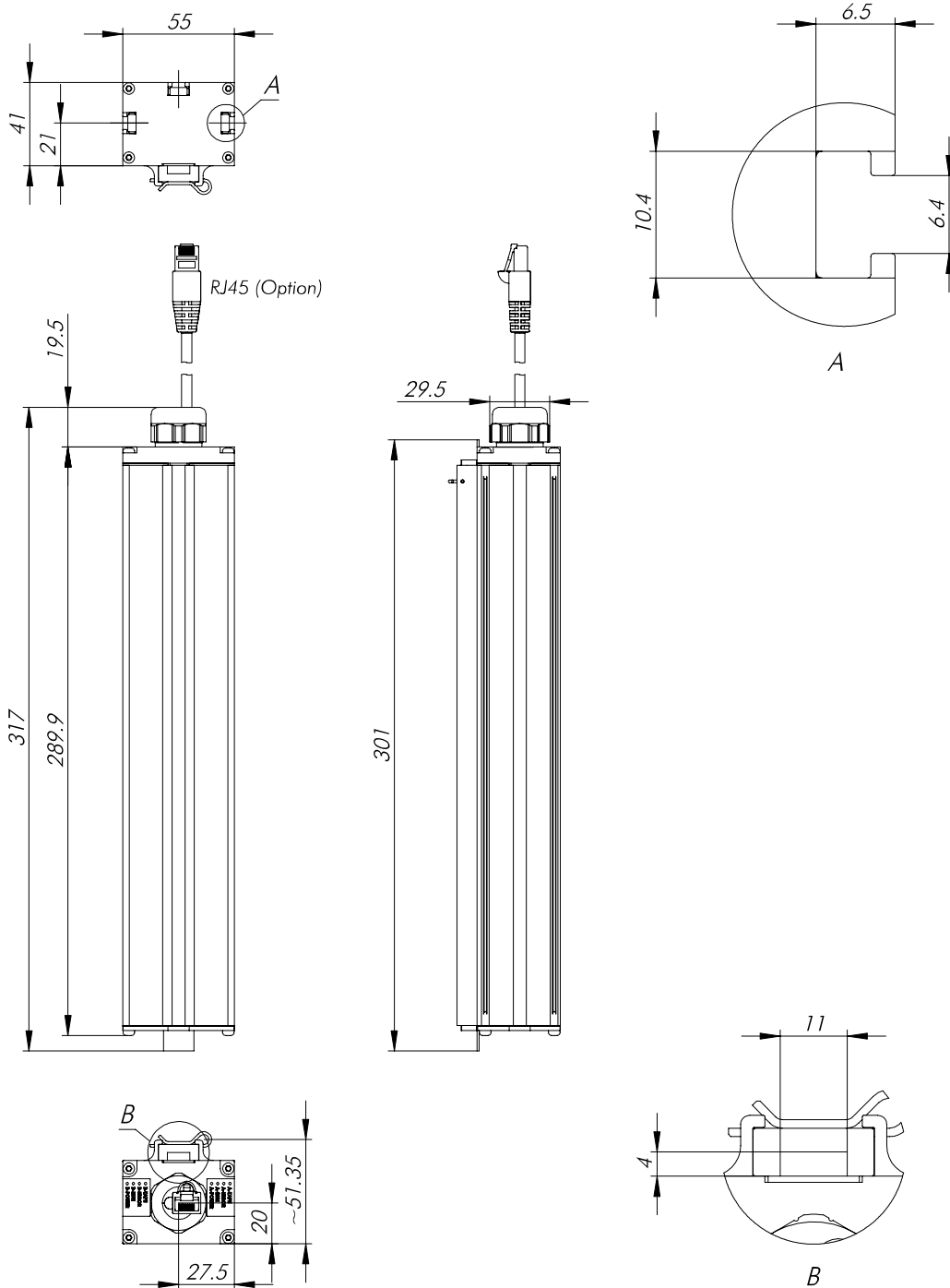

Accessories for LIMAX22 DUE:

| Order designation | Description |
|--------------------------|----------------------------------------------------------------------------|
| LIMAX2 MW SET | LIMAX22 DUE mounting angle set for attachment on the lift cabin |
| AB20-80-10-1-R-D-15-BK80 | Magnetic tape for LIMAX22 DUE, absolute coding, single track system |
| LIMAX MKF | Mounting set for suspended installation with dowel |
| LIMAX MKB | Mounting set for suspended installation with guiding rails and rail holder |
| LIMAX RMS | Mounting set for suspended installation with crossbeam for standard layout |
| LIMAX RMS 90 | Mounting set for suspended installation with crossbeam for Rucksack-layout |
| LIMAX S-RMS | Mounting set for suspended installation with crossbeam and tape detection |

