

SERIES HMIX1X

Magnetic Incremental Linear Encoder with 1 μm Resolution

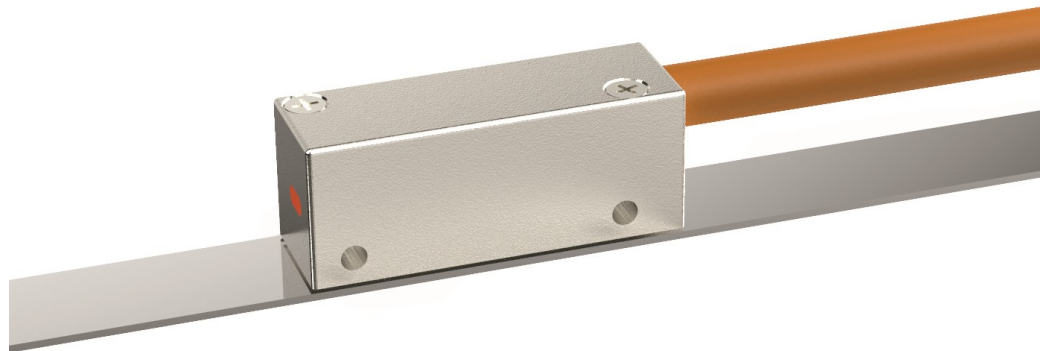

- Magnetic measuring principle with contactless scanning
- Compact sensor with integrated evaluation electronics
- Speed proportional square wave outputs
- Resolution 1 μm (at 4-edge triggering)
- Predestined linear motor applications
- With periodic index pulse output
- LED distance monitoring (option)
- Quick and easy installation
- High IP67 protection class

HMIX1X - Magnetic Incremental Linear Encoder with 1 μm Resolution

General:

The HMIX1X series is a very compact, magnetic linear encoder for high-precision measuring tasks in the μ -range. The required evaluation electronics are already integrated in the small sensor head. Thus, the system is directly ready for connecting to the follow-up circuit. HMIX1X is supplied with 5 VDC as standard.

Mounting with the Magnetic Tape:

The sensor head is guided along the measuring distance by an ELGO magnetic tape of the type MB20-10-10-1-R. For this purpose, the magnetic tape is glued to a flat surface with the supplied adhesive tape. The sensor head can be mounted with a distance of 0.2 mm to the magnetic tape (up to 0.5 mm if used without cover tape).

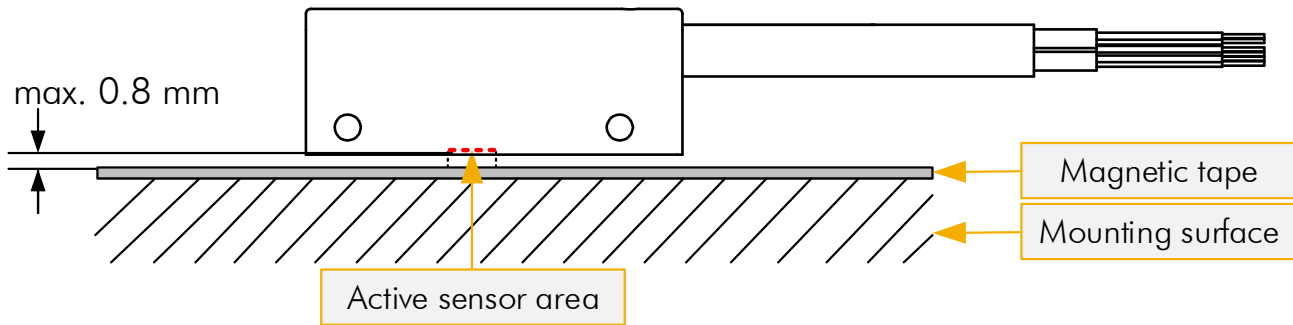

Applications:

With its high resolution of 1 μm , HMIX1X is ideal for high-precision applications such as linear motors. Thanks to the wear-free magnetic measuring principle and the high IP67 protection class, the sensor always operates unaffected and reliably even in harsh environments.

Functional Principle:

The basis of the magnetic incremental encoder consists of a scanning technology, which scans the north and south poles on the coded magnetic tape and produces a single Sine/Cosine wave for each pole. The complete sine/cosine signal process is interpolated electronically. Depending on refinement of the interpolation, together with the pole distance of the magnetic tape, the resolution of the measuring system is determined. The required magnetic tape type MB20-10-10-1-R has a pole pitch of 1 mm.

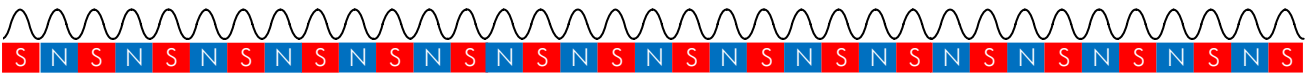

Special evaluation electronics are used to process the sinusoidal signal. It generates square wave signals from the signal information of the magnetic tape. These output signals are compatible with conventional rotary encoders or optical linear measuring systems. The output level is 5 V TTL (HTL with 10 ... 30 VDC power supply on request).

Output Pulse Diagram:

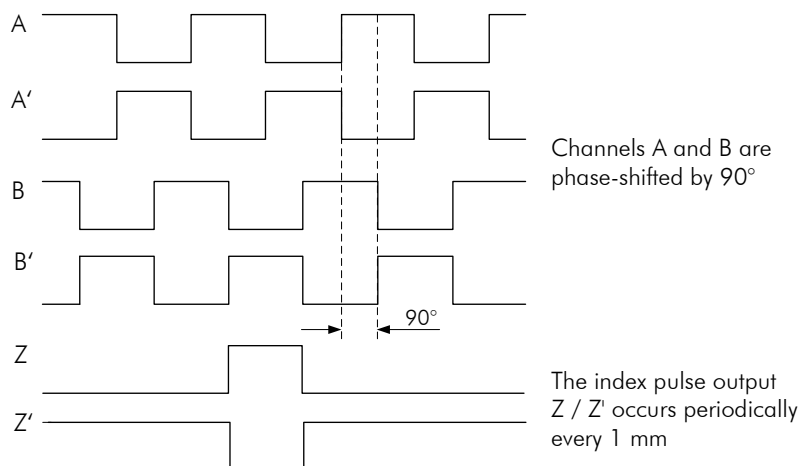

Connections:

Farbe	Function	Description
White	0 V / GND	Ground
Brown	+5 VDC	Power supply
Green	A	Channel A
Yellow	A'	Channel A'
Grey	B	Channel B
Pink	B'	Channel B'
Blue	Z	Channel Z
Red	Z'	Channel Z'
Blank	PE	Screen/shield

HMIX1X - Magnetic Incremental Linear Encoder with 1 μm Resolution

Technical Data:

Mechanical Data

Measuring principle	incremental
Repeat accuracy	$\pm 1 \mu\text{m}$
System accuracy at 20°C	$\pm (15 + 20 \times L)$ L = measuring length in meters
Max. distance sensor - tape	0.2 mm (0.5 mm without cover tape)
Housing material	zinc die cast
Housing dimensions	L x W x H = 37 x 10 x 15 mm
Required magnetic tape	MB20-10-10-1-R
Magnetic tape pole pitch	1 mm
Maximum measuring length	theoretically unlimited
Connections	open cable ends (connectors optionally)
Sensor cable	1.5 m standard cable length (others on request), drag-chain suitable
Cable bending radius	min. 60 mm
Weight	approx. 35 g (without cable); cable: approx. 60 g/m

Electrical Data

Power supply voltage	5 VDC
Residual ripple	$\pm 25 \text{ mV}$
Current consumption	max. 200 mA
Output signals	A, A', B, B', Z, Z' push-pull, durable short circuit proof
Output levels	TTL
Output current / channel	max. 20 mA
Output frequency / channel	1 MHz (higher on request)
Encoder resolution	1 μm (at 4-edge triggering)
Index pulse (Z/Z')	every 1 mm (periodically)
Operating speed	max. 2 m/s

Environmental Conditions

Storage temperature	-20 ... +85° C
Operation temperature	-10 ... +70 °C (-25 ... +85 °C on request)
Humidity	max. 95 %, non-condensing
Protection class	IP67

Dimensions:

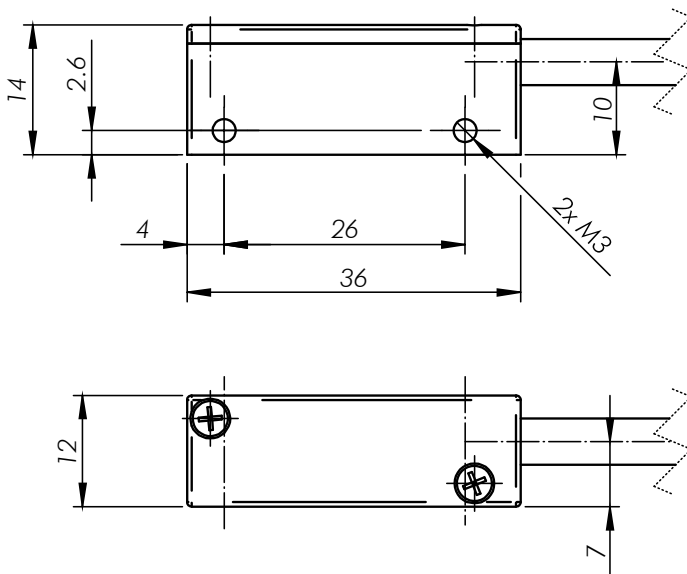

Type Designation Sensor:

To order, please use the following code:

HMIX1X - - - - -
AAA - BB.B - CCCC - DD - EE

A Version:

- 000 = standard version
- 001 = first special version etc.

B Sensor Cable Length:

- 01.5 = 1.5 m standard (others on request)

C Resolution (at 4-edge triggering)

- 0001 = 0.001 mm \triangleq 1 μm

D Power Supply / Output levels:

- 11 = 5 VDC / TTL (standard)
- 01 = 10 ... 30 VDC / TTL (on request)
- 00 = 10 ... 30 VDC / HTL (on request)

E Options:

- D1 = with 9-pin D-SUB connector
- D3 = with 8-pin round connector for SKA-1 cable
- E = with LED distance monitoring (see last page)

Example:

HMIX1X - 000 - 01.5 - 0001 - 01 - E
AAA - BB.B - CCCC - DD - EE

Standard HMIX1X with 1.5 m cable, 1 μm resolution, 10-30 VDC power supply, TTL output levels and LED distance monitoring

Type Designation Magnetic Tape:

MB20 - - - - -
AA - BB - C - D - E

A Basic Pole Pitch:

- 10 = 1 mm

B Magnetic Tape Width:

- 10 = 10 mm

C Number of Magnetic Tracks:

- 1 = Single Track System

D Tape Construction:

- R = Standard: Magnetic tape on back iron (glued with adhesive tape on the back iron side / cover tape with adhesive tape separately enclosed).

E Options:

- B = without adhesive tape on back iron side
- C = without enclosed cover tape
- D = without adhesive tape and cover tape (B+C)

Alignment of the Sensor to the Magnetic Tape:

Top view:

Magnetic tape center = Sensor center (± 2.5 mm)

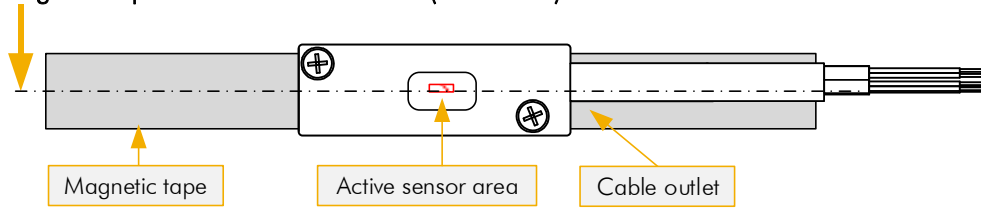

Mounting Tolerances:

Reading distance:

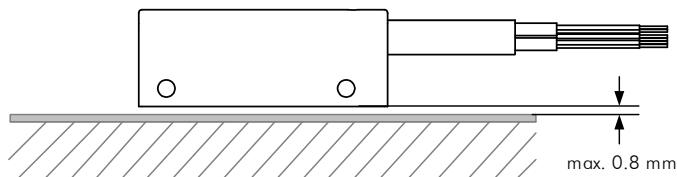

Tilt angle:

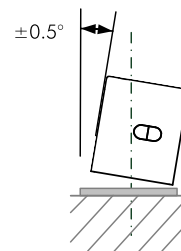

Pitch angle:

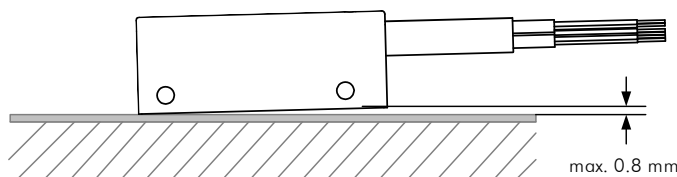

Lateral offset:

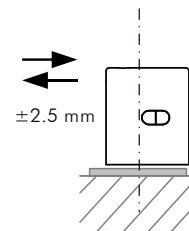

Yaw angle:

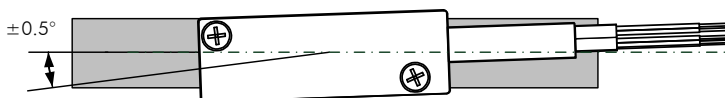

LED Distance Monitoring (Option E):

When option E is ordered, the sensor head is equipped with a monitoring LED to maintain the correct mounting distance. The LED can also assist during the installation process.

Distance LED

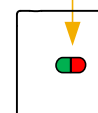

Lights up green = distance ok
Lights up red = distance not ok

Accessories:

Order Designation	Description
End cap set 10 mm	End caps for fixing the magnetic tape and protecting the magnetic tape ends
POSU	Pole finder card 85 x 55 mm (makes the magnetic tape poles visible)

