

Low backlash planetary gearheads Economy



LP+ Generation 3

Economical multitalent

- Low backlash planetary gearhead with output shaft
- Applications in cyclic or continuous operation
- Torsional backlash ≤ 8 arcmin
- Ratio: 3-100

Product highlights

- Large range of ratios
- High nominal speeds
- Optionally available with belt pulley

LPB+ Generation 3

Economical multitalent

- Low backlash planetary gearhead with output flange
- Cyclic or continuous operation
- Torsional backlash ≤ 8 arcmin
- Ratio: 3-100

Product highlights

- Large range of ratios
- High nominal speeds
- Optionally available with belt pulley

Power density ←

Versatile installation

In whatever position you install your gearhead, it always contains the same quantity of grease.

The gearheads are so flexible, you can install them vertically, horizontally or with the output facing upwards or downwards.

Extended boundaries

Our Economy range includes some impressive new additions. In the 070, 090 and 120 sizes, our LP+/LPB+ Generation 3 gearheads feature up to 75% more torque, independent of the ratio!



alpha®

Economical entry-level model

- Low backlash planetary gearhead with output shaft
- Applications in cyclic or continuous operation
- Torsional backlash ≤ 20 arcmin
- Ratio: 4-100

Product highlights

- Lightweight aluminum
- Available from our online shop: www.alpha.de (DE/AT/CH)

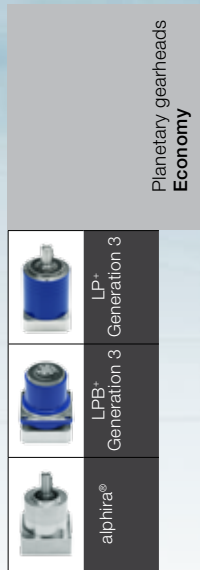

Just in time

With our Economy range, this is not merely a slogan. With our Economy range products, we set new standards with regard to delivery times and delivery reliability.

LP+/LPB+ Generation 3 – Economical multitalent

Low backlash planetary gearheads with output shaft or output flange. The LP+/LPB+ Generation 3 gearhead series combines maximum quality with economical precision. The LPB+ Generation 3 is especially suitable for compact belt drives.



Quick size selection

LP+ Generation 3 MF (example for $i = 5$)
For applications in cyclic operation ($DC \leq 60\%$)
or in continuous operation ($DC \geq 60\%$)

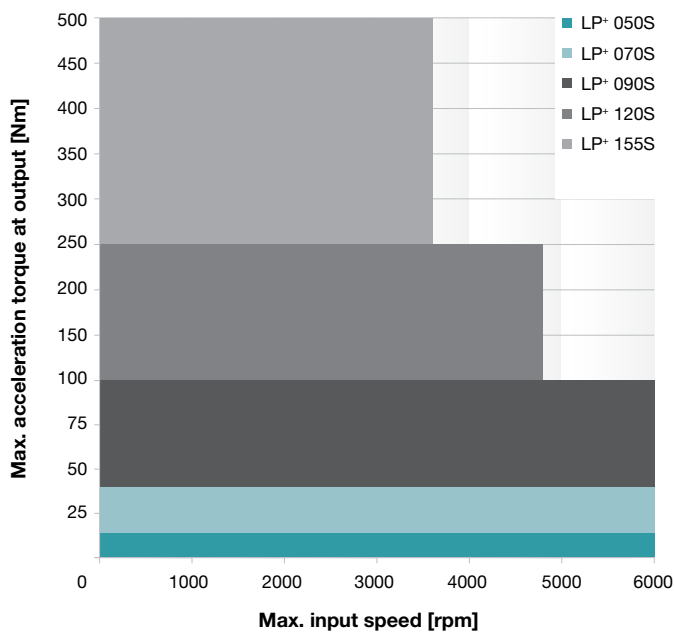

LPB+ Generation 3 MF (example for $i = 5$)
For applications in cyclic operation ($DC \leq 60\%$)
or in continuous operation ($DC \geq 60\%$)

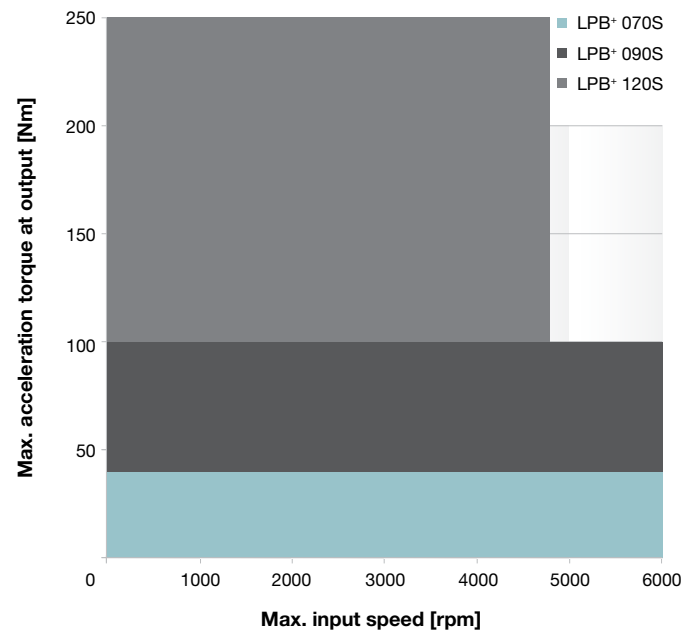

Versions and Applications

Features	LP+ Generation 3 MF version page 122	LPB+ Generation 3 MF version page 134
Power density	••	••
Positioning accuracy	•	••
High input speeds	••	••
Torsional rigidity	•	••
Space-saving design	••	•••

Product features

Ratios ^{c)}		3 – 100	3 – 100
Torsional backlash [arcmin] ^{c)}	Standard	≤ 8	≤ 8
	Reduced	-	-
Output type			
Smooth output shaft		•	
Keywayed output shaft		•	
Output flange			•
Input type			
Motor mounted version		•	•
Type			
Food-grade lubrication ^{a) b)}		•	•
Accessories			
Coupling		•	
Rack		•	
Pinion		•	
Belt pulley			•
B5 flange		•	

^{a)} Power reduction: technical data available upon request ^{b)} Please contact WITTENSTEIN alpha ^{c)} In relation to reference sizes

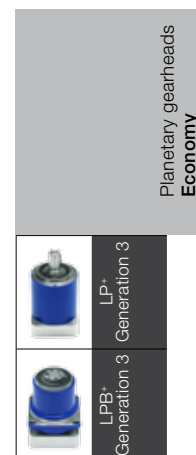

LP+ 050 MF 1/2-stage

			1-stage				2-stage							
Ratio	<i>i</i>		4	5	7	10	16	20	25	35	50	70	100	
Max. acceleration torque (max. 1000 cycles per hour)	T_{2B}	Nm	13	14	14	13	13	13	14	14	14	14	13	
		in.lb	120	120	120	120	120	120	120	120	120	120	120	
Nominal output torque (with n_m)	T_{2N}	Nm	6	6.5	6.5	6	6	6	6.5	6.5	6.5	6.5	6	
		in.lb	53	58	58	53	53	53	58	58	58	58	53	
Emergency stop torque (permitted 1000 times during the service life of the gearhead)	T_{2Not}	Nm	26	26	26	26	26	26	26	26	26	26	26	
		in.lb	230	230	230	230	230	230	230	230	230	230	230	
Nominal input speed (with T_{2N} and 20°C ambient temperature) ^{a)}	n_{1N}	rpm	4000	4000	4000	4000	4000	4000	4000	4000	4000	4000	4000	
Max. input speed	n_{1Max}	rpm	8000	8000	8000	8000	8000	8000	8000	8000	8000	8000	8000	
Mean no load running torque (with $n_1=3000$ rpm and 20°C gearhead temperature)	T_{012}	Nm	0.05	0.05	0.05	0.05	0.05	0.05	0.05	0.05	0.05	0.05	0.05	
		in.lb	0.4	0.4	0.4	0.4	0.4	0.4	0.4	0.4	0.4	0.4	0.4	
Max. torsional backlash	j_t	arcmin	≤ 10				≤ 13							
Torsional rigidity	C_{t21}	Nm/ arcmin	1.5	1.2	1.2	0.9	1.5	1.5	1.2	1.2	1.2	1.2	0.9	
		in.lb/ arcmin	13	11	11	8	13	13	11	11	11	11	8	
Max. axial force ^{b)}	F_{2AMax}	N	700				700							
		lb _f	160				160							
Max. radial force ^{b)}	F_{2RMax}	N	650				650							
		lb _f	150				150							
Efficiency at full load	η	%	97				95							
Service life (For calculation, see the Chapter "Information")	L_h	h	> 20000				> 20000							
Weight incl. standard adapter plate	m	kg	0.75				0.95							
		lb _m	1.7				2.1							
Operating noise for $i=10$ and $n_1=3000$ rpm without load	L_{PA}	dB(A)	≤ 62											
Max. permitted housing temperature	°C		+90											
	F		194											
Ambient temperature	°C		-15 to +40											
	F		5 to 104											
Lubrication	Lubricated for life													
Paint	Blue RAL 5002													
Direction of rotation	Motor and gearhead same direction													
Protection class	IP 64													
Moment of inertia (relates to the drive)	B	11	J_f	kgcm ²	0.05	0.05	0.05	0.05	0.05	0.05	0.05	0.05	0.05	0.05
				10 ⁻³ in.lb.s ²	0.05	0.04	0.04	0.04	0.05	0.04	0.04	0.04	0.04	0.04
Clamping hub diameter (mm)	C	14	J_f	kgcm ²	0.2	0.2	0.2	0.2	0.2	0.2	0.2	0.2	0.2	
				10 ⁻³ in.lb.s ²	0.2	0.2	0.2	0.2	0.2	0.2	0.2	0.2	0.2	0.2

^{a)} For higher ambient temperatures, please reduce input speed

^{b)} Refers to center of the output shaft, if $n_2 = 100$ rpm

View A

View B

LP+ 1-stage:

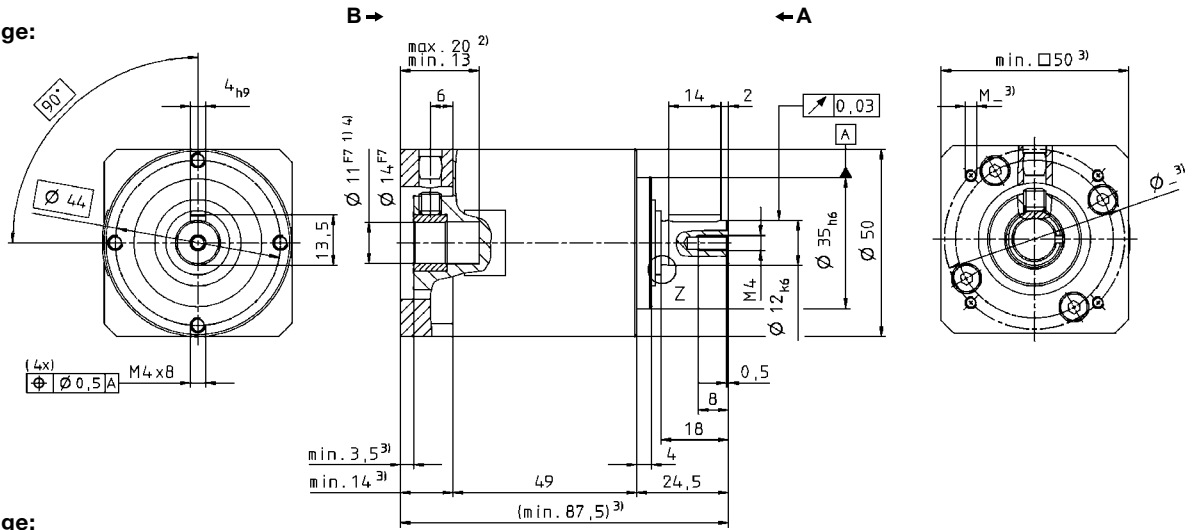

LP+ 2-stage:

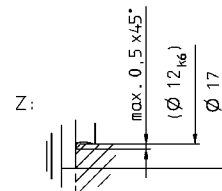
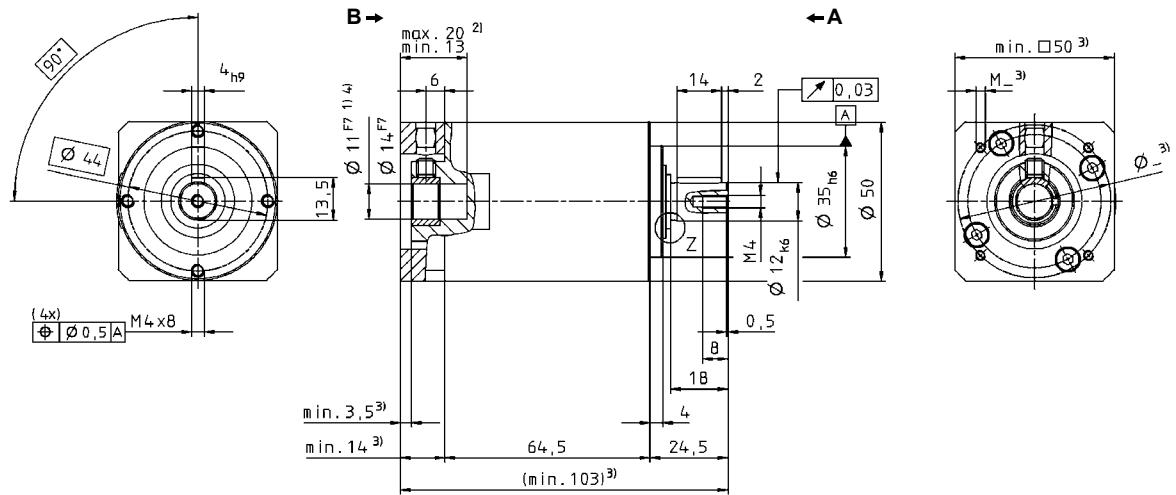

Non-tolerated dimensions $\pm 1\text{mm}$

- 1) Check motor shaft fit.
- 2) Min./Max. permissible motor shaft length. Longer motor shafts are adaptable, please contact us.
- 3) The dimensions depend on the motor.
- 4) Smaller motor shaft diameter is compensated by a bushing. Motor shaft diameters up to 14mm available – please contact WITTENSTEIN alpha

CAD data is available under www.wittenstein-alpha.com

Motor mounting according to operating manual

LP+ 070 MF 1/2-stage

			1-stage					2-stage										
Ratio ^{a)}	<i>i</i>		3	4	5	7	10	9	12	16	20	25	30	40	50	70	100	
Max. acceleration torque (max. 1000 cycles per hour)	T_{2B}	Nm	55	42	40	40	37	55	55	42	42	40	55	42	40	40	37	
		in.lb	490	370	350	350	330	490	490	490	370	350	490	370	350	350	350	330
Nominal output torque (with n_m)	T_{2N}	Nm	29	22	21	21	19	29	29	22	22	21	29	22	21	21	19	
		in.lb	260	190	190	190	170	260	260	260	190	190	260	190	190	190	170	
Emergency stop torque (permitted 1000 times during the service life of the gearhead)	T_{2Not}	Nm	65	75	75	75	75	75	75	75	75	75	75	75	75	75	75	
		in.lb	580	660	660	660	660	660	660	660	660	660	660	660	660	660	660	
Nominal input speed (with T_{2N} and 20°C ambient temperature) ^{b)}	n_{1N}	rpm	3700	3700	3700	3700	3700	3700	3700	3700	3700	3700	3700	3700	3700	3700	3700	
Max. input speed	n_{1Max}	rpm	6000	6000	6000	6000	6000	6000	6000	6000	6000	6000	6000	6000	6000	6000	6000	
Mean no load running torque (with $n_1=3000$ rpm and 20°C gearhead temperature)	T_{012}	Nm	0.3	0.3	0.2	0.1	0.1	0.1	0.1	0.1	0.1	0.1	0.1	0.1	0.1	0.1	0.1	
		in.lb	2.7	2.2	1.8	1.2	1.2	1.2	1.2	1.2	1.2	1.2	1.2	1.2	1.2	1.2	1.2	
Max. torsional backlash	j_t	arcmin	≤ 8					≤ 10										
Torsional rigidity	C_{t21}	Nm/ arcmin	4	4	3.3	3.3	2.8	4.0	4.0	4.0	4.0	4.0	4.0	3.3	3.3	3.3	2.8	
		in.lb/ arcmin	35	35	29	29	25	35	35	35	35	35	35	29	29	29	25	
Max. axial force ^{c)}	F_{2AMax}	N	1550					1550										
		lb _f	349					349										
Max. radial force ^{c)}	F_{2RMax}	N	1450					1450										
		lb _f	326					326										
Efficiency at full load	η	%	97					95										
Service life (For calculation, see the Chapter "Information")	L_n	h	> 20000					> 20000										
Weight incl. standard adapter plate	<i>m</i>	kg	2.0					2.4										
		lb _m	4.4					5.3										
Operating noise for $i=10$ and $n_1 = 3000$ rpm without load	L_{PA}	dB(A)	≤ 64															
Max. permitted housing temperature	°C		+90															
	F		194															
Ambient temperature	°C		-15 to +40															
	F		5 to 104															
Lubrication			Lubricated for life															
Paint			Blue RAL 5002															
Direction of rotation			Motor and gearhead same direction															
Protection class			IP 64															
Moment of inertia (relates to the drive)	D	16	J_f	kgcm ²	0.3	0.3	0.2	0.2	0.2	0.2	0.2	0.2	0.2	0.2	0.2	0.2	0.2	0.2
				10 ⁻³ in.lb.s ²	0.3	0.2	0.2	0.2	0.2	0.2	0.2	0.2	0.2	0.2	0.2	0.2	0.2	0.2
Clamping hub diameter (mm)	E	19	J_f	kgcm ²	0.6	0.5	0.5	0.5	0.5	0.5	0.5	0.5	0.5	0.5	0.5	0.5	0.5	
				10 ⁻³ in.lb.s ²	0.5	0.5	0.5	0.4	0.4	0.5	0.5	0.5	0.5	0.5	0.4	0.5	0.4	0.4

^{a)} Other ratios are available on request: $i = 15, 21, 28$ and 35 .

^{b)} For higher ambient temperatures, please reduce input speed

^{c)} Refers to center of the output shaft, if $n_2 = 100$ rpm

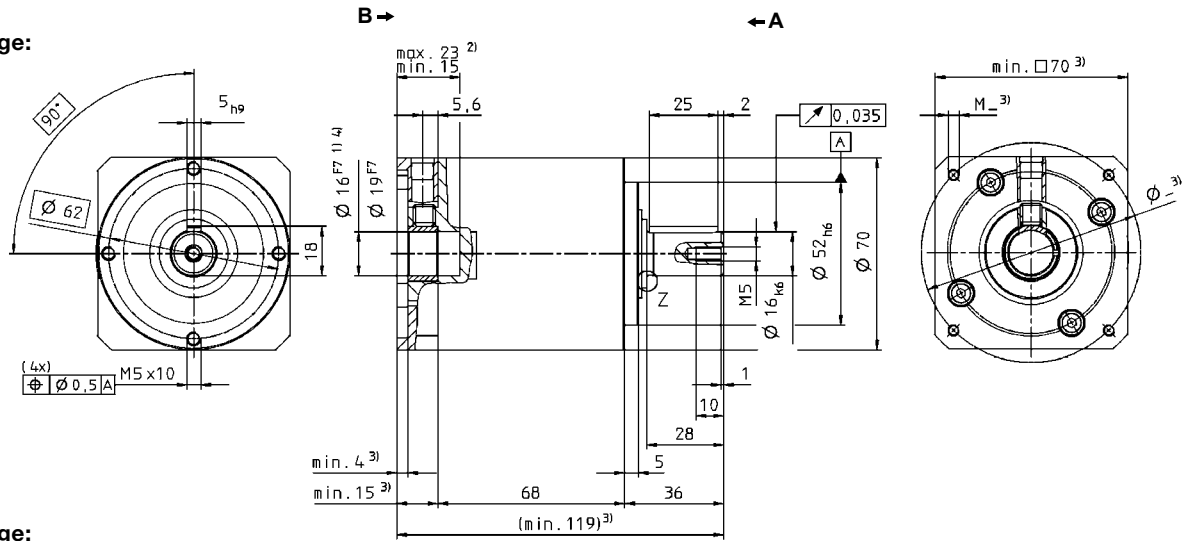
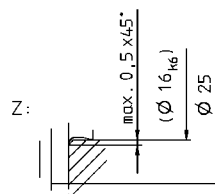
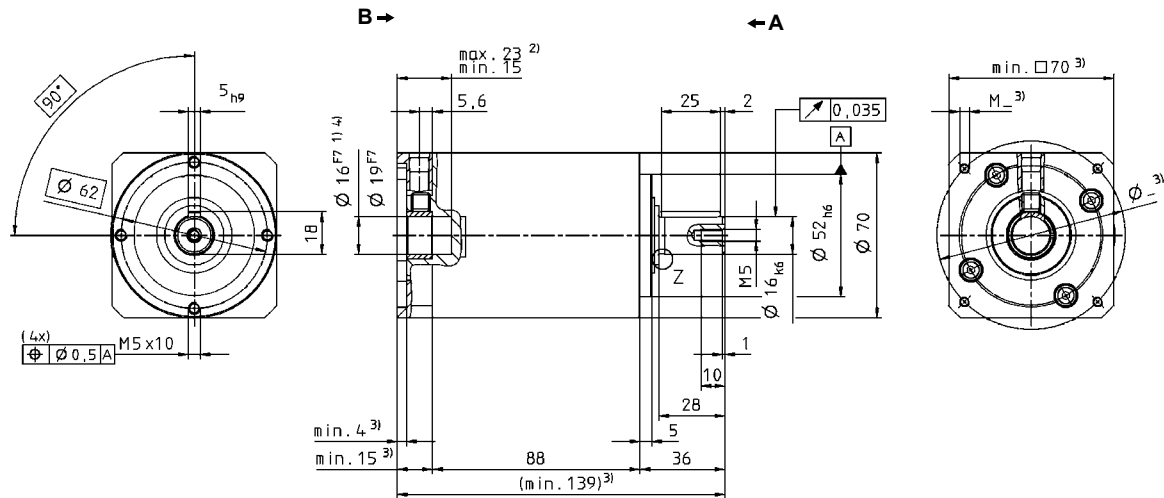
LP+ 1-stage:

LP+ 2-stage:

 Non-tolerated dimensions $\pm 1\text{mm}$

- 1) Check motor shaft fit.
- 2) Min./Max. permissible motor shaft length. Longer motor shafts are adaptable, please contact us.
- 3) The dimensions depend on the motor.
- 4) Smaller motor shaft diameter is compensated by a bushing. Motor shaft diameters up to 19mm available – please contact WITTENSTEIN alpha

 CAD data is available under www.wittenstein-alpha.com

Motor mounting according to operating manual

LP+ 090 MF 1/2-stage

			1-stage					2-stage										
Ratio ^{a)}	<i>i</i>		3	4	5	7	10	9	12	16	20	25	30	40	50	70	100	
Max. acceleration torque (max. 1000 cycles per hour)	T_{2B}	Nm	125	115	100	100	90	125	125	115	115	100	125	115	100	100	90	
		in.lb	1110	1020	890	890	800	1110	1110	1020	1020	890	1110	1020	890	890	800	
Nominal output torque (with n_m)	T_{2N}	Nm	63	58	50	50	45	63	63	58	58	50	63	58	50	50	45	
		in.lb	560	510	440	440	400	560	560	510	510	440	560	510	440	440	400	
Emergency stop torque (permitted 1000 times during the service life of the gearhead)	T_{2Not}	Nm	185	190	190	190	190	190	190	190	190	190	190	190	190	190	190	
		in.lb	1640	1680	1680	1680	1680	1680	1680	1680	1680	1680	1680	1680	1680	1680	1680	
Nominal input speed (with T_{2N} and 20°C ambient temperature) ^{b)}	n_{1N}	rpm	3400	3400	3400	3400	3400	3400	3400	3400	3400	3400	3400	3400	3400	3400	3400	
Max. input speed	n_{1Max}	rpm	6000	6000	6000	6000	6000	6000	6000	6000	6000	6000	6000	6000	6000	6000	6000	
Mean no load running torque (with $n_1=3000$ rpm and 20°C gearhead temperature)	T_{012}	Nm	0.6	0.6	0.5	0.4	0.4	0.3	0.3	0.3	0.3	0.3	0.3	0.3	0.3	0.3	0.3	
		in.lb	5.3	4.9	4.4	3.5	3.4	2.7	2.7	2.7	2.7	2.7	2.7	2.7	2.7	2.2	2.2	
Max. torsional backlash	j_t	arcmin	≤ 8					≤ 10										
Torsional rigidity	C_{t21}	Nm/arcmin	12	12	9.5	9.5	8.5	12	12	12	12	9.5	9.5	12	9.5	9.5	8.5	
		in.lb/arcmin	106	106	84	84	75	106	106	106	106	84	84	106	84	84	75	
Max. axial force ^{c)}	F_{2AMax}	N	1900					1900										
		lb _f	430					430										
Max. radial force ^{c)}	F_{2RMax}	N	2400					2400										
		lb _f	540					540										
Efficiency at full load	η	%	97					95										
Service life (For calculation, see the Chapter "Information")	L_n	h	> 20000					> 20000										
Weight incl. standard adapter plate	<i>m</i>	kg	4.0					5.0										
		lb _m	8.8					11										
Operating noise for $i=10$ and $n_1=3000$ rpm without load	L_{PA}	dB(A)	≤66															
Max. permitted housing temperature	°C		+90															
	F		194															
Ambient temperature	°C		-15 to +40															
	F		5 to 104															
Lubrication			Lubricated for life															
Paint			Blue RAL 5002															
Direction of rotation			Motor and gearhead same direction															
Protection class			IP 64															
Moment of inertia (relates to the drive)	G	24	J_f	kgcm ²	1.8	1.6	1.6	1.5	1.4	1.5	1.5	1.6	1.6	1.5	1.5	1.4	1.4	1.4
				10 ⁻³ in.lb.s ²	1.6	1.4	1.4	1.3	1.3	1.3	1.3	1.4	1.4	1.3	1.3	1.3	1.3	1.3
Clamping hub diameter (mm)	H	28	J_f	kgcm ²	2.1	1.9	1.9	1.8	1.7	1.8	1.8	1.9	1.9	1.8	1.8	1.7	1.7	1.7
				10 ⁻³ in.lb.s ²	1.9	1.7	1.6	1.6	1.5	1.6	1.6	1.6	1.6	1.6	1.6	1.5	1.5	1.5

^{a)} Other ratios are available on request: $i = 15, 21, 28$ and 35 .

^{b)} For higher ambient temperatures, please reduce input speed

^{c)} Refers to center of the output shaft, if $n_2 = 100$ rpm

LP+ 1-stage:

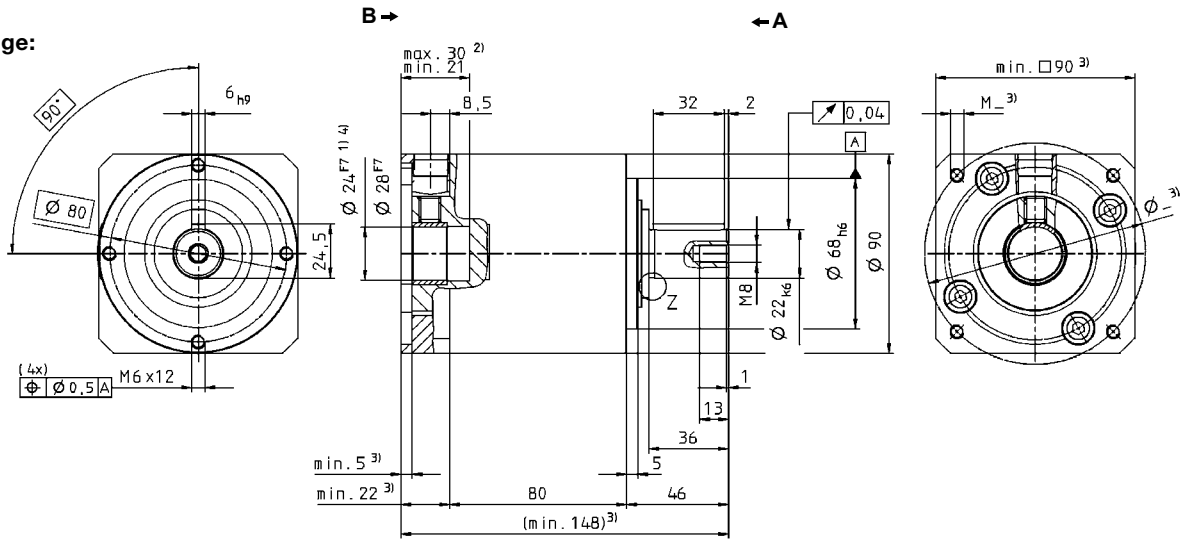

LP+ 2-stage:

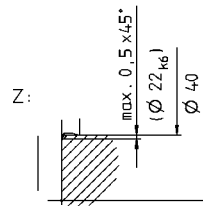
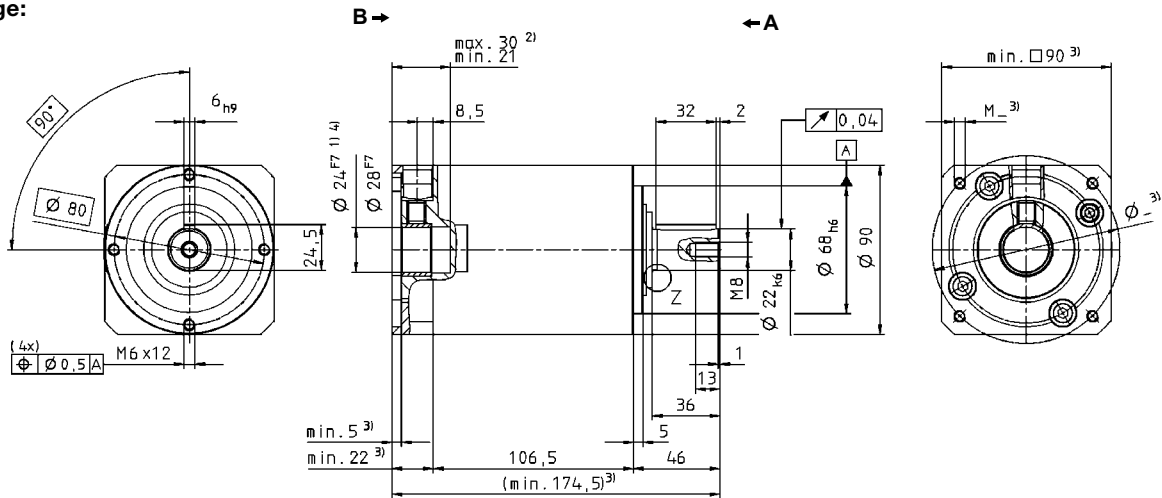

Non-tolerated dimensions $\pm 1\text{mm}$

- 1) Check motor shaft fit.
- 2) Min./Max. permissible motor shaft length. Longer motor shafts are adaptable, please contact us.
- 3) The dimensions depend on the motor.
- 4) Smaller motor shaft diameter is compensated by a bushing. Motor shaft diameters up to 28mm available – please contact WITTENSTEIN alpha

CAD data is available under www.wittenstein-alpha.com

Motor mounting according to operating manual

LP+ 120 MF 1/2-stage

			1-stage					2-stage										
Ratio ^{a)}	<i>i</i>		3	4	5	7	10	9	12	16	20	25	30	40	50	70	100	
Max. acceleration torque (max. 1000 cycles per hour)	T_{2B}	Nm	305	305	250	250	220	305	305	305	305	250	305	305	250	250	220	
		in.lb	2700	2700	2210	2210	1950	2700	2700	2700	2700	2210	2700	2700	2210	2210	1950	
Nominal output torque (with n_m)	T_{2N}	Nm	155	155	125	125	110	155	155	155	155	125	155	155	125	125	110	
		in.lb	1370	1370	1110	1110	970	1370	1370	1370	1370	1110	1370	1370	1110	1110	970	
Emergency stop torque (permitted 1000 times during the service life of the gearhead)	T_{2Not}	Nm	400	480	480	480	480	480	480	480	480	480	480	480	480	480	480	
		in.lb	3540	4250	4250	4250	4250	4250	4250	4250	4250	4250	4250	4250	4250	4250	4250	
Nominal input speed (with T_{2N} and 20°C ambient temperature) ^{b)}	n_{1N}	rpm	2600	2600	2600	2600	2600	2600	2600	2600	2600	2600	2600	2600	2600	2600	2600	
Max. input speed	n_{1Max}	rpm	4800	4800	4800	4800	4800	4800	4800	4800	4800	4800	4800	4800	4800	4800	4800	
Mean no load running torque (with $n_1=3000$ rpm and 20°C gearhead temperature)	T_{012}	Nm	1.1	1.0	0.9	0.8	0.8	0.6	0.6	0.6	0.5	0.5	0.4	0.5	0.4	0.4	0.4	
		in.lb	9.7	8.9	8.0	7.1	7.1	5.3	5.3	4.9	4.4	4.4	3.5	4.4	3.5	3.5	3.5	
Max. torsional backlash	j_t	arcmin	≤ 8					≤ 10										
Torsional rigidity	C_{t21}	Nm/arcmin	30	30	25	25	22	30	30	30	30	25	25	30	25	25	22	
		in.lb/arcmin	270	270	220	220	190	270	270	270	270	220	220	270	220	220	190	
Max. axial force ^{c)}	F_{2AMax}	N	4000					4000										
		lb _f	900					900										
Max. radial force ^{c)}	F_{2RMax}	N	4600					4600										
		lb _f	1035					1035										
Efficiency at full load	η	%	97					95										
Service life (For calculation, see the Chapter "Information")	L_n	h	> 20000					> 20000										
Weight incl. standard adapter plate	m	kg	8.6					11.0										
		lb _m	19.0					24.3										
Operating noise for $i=10$ and $n_1=3000$ rpm without load	L_{PA}	dB(A)	≤ 68															
Max. permitted housing temperature	°C		+90															
	F		194															
Ambient temperature	°C		-15 to +40															
	F		5 to 104															
Lubrication			Lubricated for life															
Paint			Blue RAL 5002															
Direction of rotation			Motor and gearhead same direction															
Protection class			IP 64															
Moment of inertia (relates to the drive)	I	32	J_f	kgcm ²	6.9	5.9	5.6	5.2	5.1	5.4	5.4	5.5	5.5	5.3	5.3	5.0	5.0	5.0
				10 ⁻³ in.lb.s ²	6.1	5.3	4.9	4.6	4.5	4.7	4.7	4.9	4.9	4.7	4.7	4.4	4.4	4.4
Clamping hub diameter (mm)	K	38	J_f	kgcm ²	7.8	6.8	6.4	6.1	5.9	6.2	6.2	6.4	6.4	6.2	6.2	5.9	5.9	5.9
				10 ⁻³ in.lb.s ²	6.9	6.0	5.7	5.4	5.2	5.5	5.5	5.7	5.7	5.5	5.5	5.2	5.2	5.2

^{a)} Other ratios are available on request: $i = 15, 21, 28$ and 35 .

^{b)} For higher ambient temperatures, please reduce input speed

^{c)} Refers to center of the output shaft, if $n_2 = 100$ rpm

LP+ 1-stage:

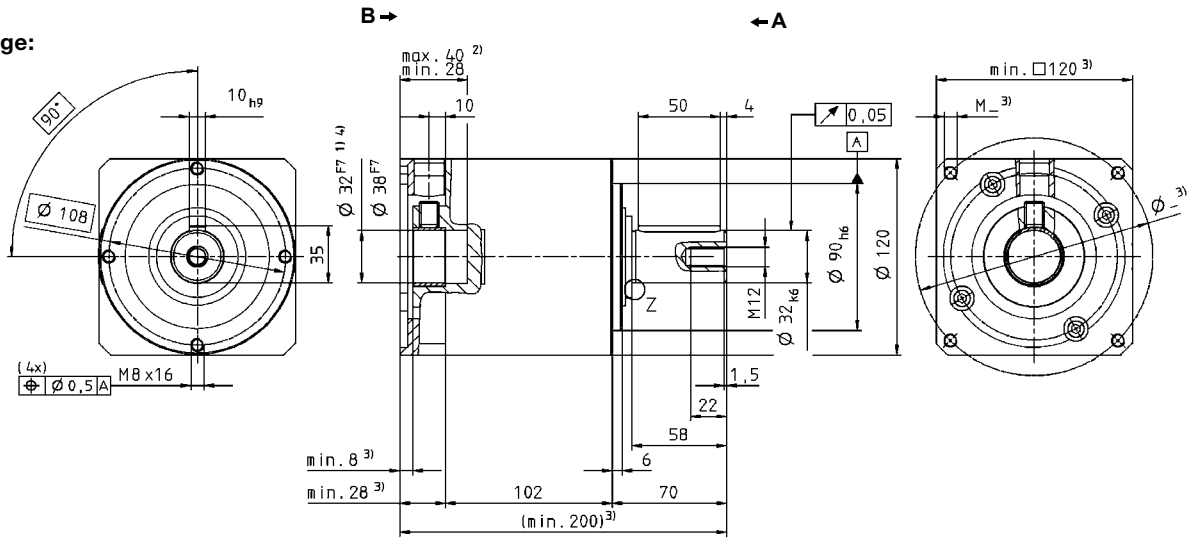

LP+ 2-stage:

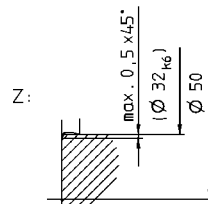
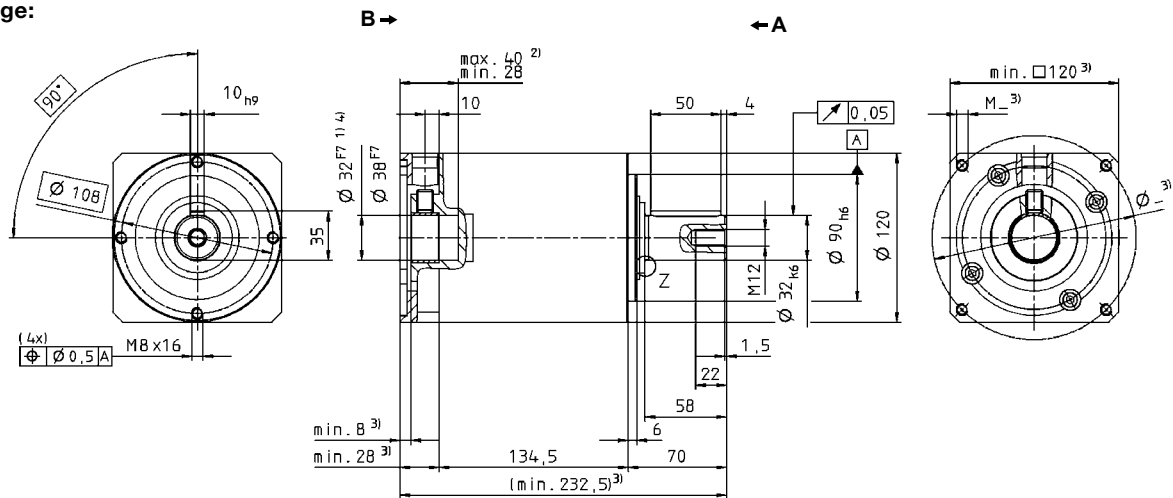

Non-tolerated dimensions $\pm 1\text{mm}$

- 1) Check motor shaft fit.
- 2) Min./Max. permissible motor shaft length. Longer motor shafts are adaptable, please contact us.
- 3) The dimensions depend on the motor.
- 4) Smaller motor shaft diameter is compensated by a bushing. Motor shaft diameters up to 38mm available – please contact WITTENSTEIN alpha

CAD data is available under www.wittenstein-alpha.com

Motor mounting according to operating manual

LP+ 155 MF 1/2-stage

			1-stage		2-stage				
Ratio	<i>i</i>		5	10	25	50	100		
Max. acceleration torque (max. 1000 cycles per hour)	T_{2B}	Nm	500	400	500	500	400		
		in.lb	4430	3540	4430	4430	3540		
Nominal output torque (with n_m)	T_{2N}	Nm	350	200	350	350	200		
		in.lb	3100	1770	3100	3100	1770		
Emergency stop torque (permitted 1000 times during the service life of the gearhead)	T_{2Not}	Nm	1000	1000	1000	1000	1000		
		in.lb	8850	8850	8850	8850	8850		
Nominal input speed (with T_{2N} and 20°C ambient temperature) ^{a)}	n_{1N}	rpm	2000	2000	2000	2000	2000		
Max. input speed	n_{1Max}	rpm	3600	3600	3600	3600	3600		
Mean no load running torque (with $n_1=3000$ rpm and 20°C gearhead temperature)	T_{012}	Nm	2.8	2.5	1.0	0.8	0.7		
		in.lb	25	22	8.9	7.1	6.2		
Max. torsional backlash	j_t	arcmin	≤ 8		≤ 10				
Torsional rigidity	C_{t21}	Nm/ arcmin	55	44	55	55	44		
		in.lb/ arcmin	490	390	490	490	390		
Max. axial force ^{b)}	F_{2AMax}	N	6000			6000			
		lb _f	1350			1350			
Max. radial force ^{b)}	F_{2RMax}	N	7500			7500			
		lb _f	1690			1690			
Efficiency at full load	η	%	97			95			
Service life (For calculation, see the Chapter "Information")	L_n	h	> 20000			> 20000			
Weight incl. standard adapter plate	<i>m</i>	kg	17			21			
		lb _m	38			46			
Operating noise for $i=10$ and $n_1=3000$ rpm without load	L_{PA}	dB(A)	≤ 69						
Max. permitted housing temperature			°C						
			F						
Ambient temperature			°C						
			F						
Lubrication	Lubricated for life								
Paint	Blue RAL 5002								
Direction of rotation	Motor and gearhead same direction								
Protection class	IP 64								
Moment of inertia (relates to the drive)	L	42	J_1	kgcm ²	17	16	–	–	–
				10 ² in.lb.s ²	15	14	–	–	–
Clamping hub diameter (mm)	I	32	J_1	kgcm ²	–	–	5.4	5.0	5.0
				10 ² in.lb.s ²	–	–	4.8	4.4	4.4
	K	38	J_1	kgcm ²	–	–	6.3	5.9	5.9
				10 ² in.lb.s ²	–	–	5.5	5.2	5.2

^{a)} For higher ambient temperatures, please reduce input speed

^{b)} Refers to center of the output shaft, if $n_2 = 100$ rpm

LP+ 1-stage:

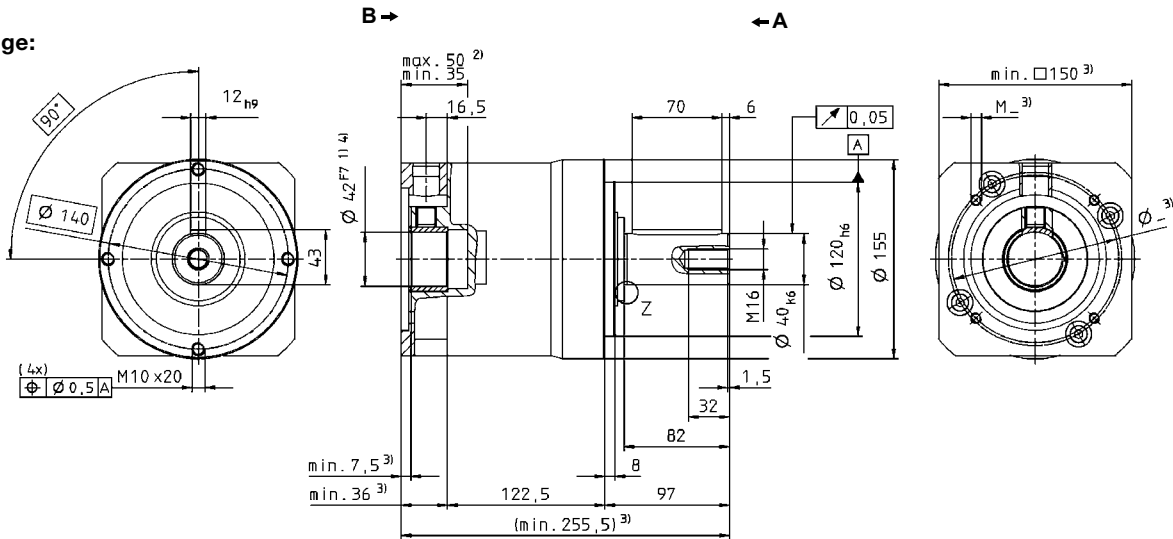

LP+ 2-stage:

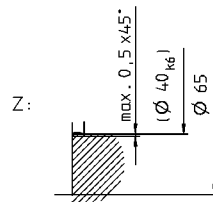
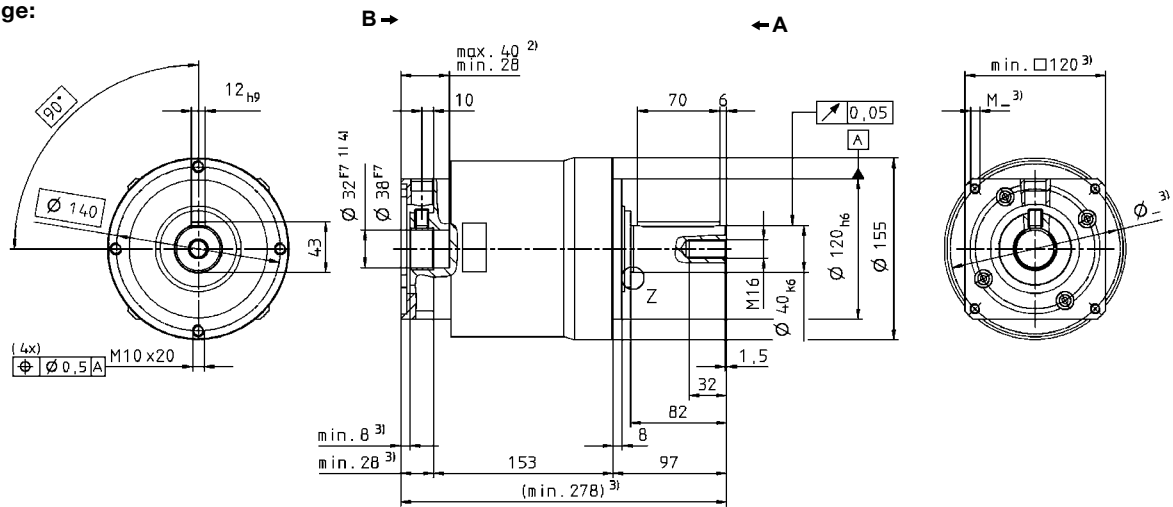

Non-tolerated dimensions ±1mm

- 1) Check motor shaft fit.
- 2) Min./Max. permissible motor shaft length. Longer motor shafts are adaptable, please contact us.
- 3) The dimensions depend on the motor.
- 4) Smaller motor shaft diameter is compensated by a bushing.
LP+ 2-stage: Motor shaft diameters up to 38mm available – please contact WITTENSTEIN alpha

CAD data is available under www.wittenstein-alpha.com

Motor mounting according to operating manual

LPB+ 070 MF 1/2-stage

			1-stage					2-stage									
Ratio ^{d)}	<i>i</i>		3	4	5	7	10	9	12	16	20	25	30	40	50	70	100
Max. acceleration torque (max. 1000 cycles per hour)	T_{2B}	Nm	55	42	40	40	37	55	55	42	42	40	55	42	40	40	37
		in.lb	490	370	350	350	330	490	490	370	370	350	490	370	350	350	330
Nominal output torque (with n_m)	T_{2N}	Nm	29	22	21	21	19	29	29	22	22	21	29	22	21	21	19
		in.lb	260	190	190	190	170	260	260	190	190	190	260	190	190	190	170
Emergency stop torque (permitted 1000 times during the service life of the gearhead)	T_{2Not}	Nm	65	75	75	75	75	75	75	75	75	75	75	75	75	75	75
		in.lb	580	660	660	660	660	660	660	660	660	660	660	660	660	660	660
Nominal input speed (with T_{2N} and 20°C ambient temperature) ^{a)}	n_{1N} rpm		3700	3700	3700	3700	3700	3700	3700	3700	3700	3700	3700	3700	3700	3700	3700
Max. input speed	n_{1Max} rpm		6000	6000	6000	6000	6000	6000	6000	6000	6000	6000	6000	6000	6000	6000	6000
Mean no load running torque (with $n_i=3000$ rpm and 20°C gearhead temperature)	T_{012}	Nm	0.3	0.3	0.2	0.1	0.1	0.1	0.1	0.1	0.1	0.1	0.1	0.1	0.1	0.1	0.1
		in.lb	2.7	2.2	1.8	1.2	1.2	1.2	1.2	1.2	1.2	1.2	1.2	1.2	1.2	1.2	1.2
Max. torsional backlash	j_t arcmin	≤ 8					≤ 10										
Torsional rigidity	C_{t21}	Nm/ arcmin	6.4	6.4	4.8	4.8	3.8	6.4	6.4	6.4	6.4	4.8	6.4	6.4	4.8	4.8	4.8
		in.lb/ arcmin	55	55	40	40	35	55	55	55	55	40	55	55	40	40	35
Max. axial force ^{b)}	F_{2AMax}	N	1550					1550									
		lb _f	350					350									
Max. radial force ^{c)}	F_{2RMax}	N	3000					3000									
		lb _f	680					680									
Efficiency at full load	η %	97					95										
Service life (For calculation, see the Chapter "Information")	L_h h	> 20000					> 20000										
Weight incl. standard adapter plate	<i>m</i>	kg	1.6					2									
		lb _m	3.5					4.4									
Operating noise for $i=10$ and $n_i=3000$ rpm without load	L_{PA} dB(A)	≤64															
Max. permitted housing temperature	°C	+90															
	F	194															
Ambient temperature	°C	-15 to +40															
	F	5 to 104															
Lubrication	Lubricated for life																
Paint	Blue RAL 5002																
Direction of rotation	Motor and gearhead same direction																
Protection class	IP 64																
Moment of inertia (relates to the drive)	D	16	J_f	kgcm ²	0.3	0.3	0.2	0.2	0.2	0.2	0.2	0.2	0.2	0.2	0.2	0.2	0.2
				10 ⁻³ in.lb.s ²	0.3	0.2	0.2	0.2	0.2	0.2	0.2	0.2	0.2	0.2	0.2	0.2	0.2
Clamping hub diameter (mm)	E	19	J_f	kgcm ²	0.6	0.5	0.5	0.5	0.5	0.5	0.5	0.5	0.5	0.5	0.5	0.5	
				10 ⁻³ in.lb.s ²	0.5	0.5	0.5	0.4	0.4	0.5	0.5	0.5	0.5	0.5	0.5	0.4	0.4

^{a)} For higher ambient temperatures, please reduce input speed

^{b)} Based on the center of the output flange at $n_2 = 100$ rpm

^{c)} With mounted PLPB+ belt pulley and 100 rpm

^{d)} Other ratios are available on request: $i = 15, 21, 28$ and 35 .

LPB+ 1-stage:

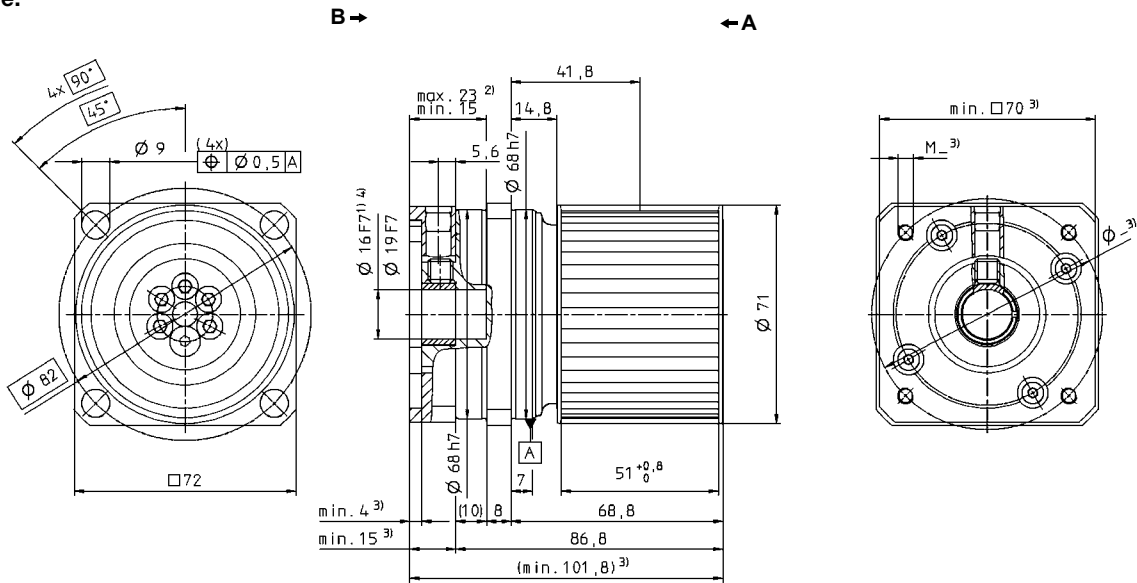

LPB+ 2-stage:

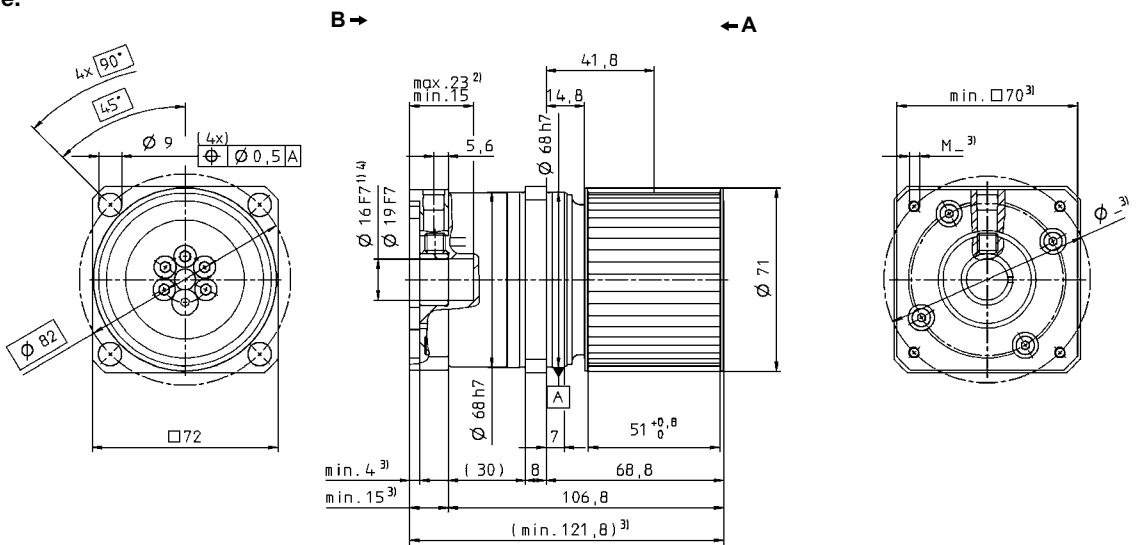

Supplement: Belt pulley PLPB+ (not included in the scope of delivery – please order separately)

Illustration: Output flange without belt pulley

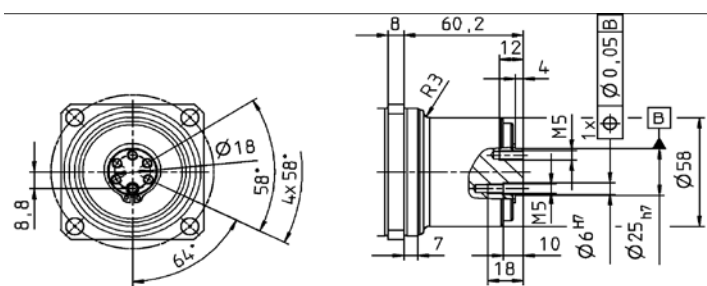

Belt Pulley PLPB+ 070 Profile AT5-0			
Pitch	p	mm	5
Number of teeth	z		43
Circumference	$z * p$	mm/rotation	215
Inertia	J	kgcm ²	3.86
Mass	m	kg	0.48

- Non-tolerated dimensions ±1mm
- 1) Check motor shaft fit.
 - 2) Min./Max. permissible motor shaft length. Longer motor shafts are adaptable, please contact us.
 - 3) The dimensions depend on the motor.
 - 4) Smaller motor shaft diameter is compensated by a bushing. Motor shaft diameters up to 19mm available – please contact WITTENSTEIN alpha

CAD data is available under www.wittenstein-alpha.com

Motor mounting according to operating manual

Planetary gearheads
Economy

LPB+
Generation 3

LPB+ 090 MF 1/2-stage

			1-stage					2-stage										
Ratio ^{d)}	<i>i</i>		3	4	5	7	10	9	12	16	20	25	30	40	50	70	100	
Max. acceleration torque (max. 1000 cycles per hour)	T_{2B}	Nm	125	115	100	100	90	125	125	115	115	100	125	115	100	100	90	
		in.lb	1110	1020	890	890	800	1110	1110	1020	1020	890	1110	1020	890	890	800	
Nominal output torque (with n_m)	T_{2N}	Nm	63	58	50	50	45	63	63	58	58	50	63	58	50	50	45	
		in.lb	560	510	440	440	400	560	560	510	510	440	560	510	440	440	400	
Emergency stop torque (permitted 1000 times during the service life of the gearhead)	T_{2Not}	Nm	185	190	190	190	190	190	190	190	190	190	190	190	190	190	190	
		in.lb	1640	1680	1680	1680	1680	1680	1680	1680	1680	1680	1680	1680	1680	1680	1680	
Nominal input speed (with T_{2N} and 20°C ambient temperature) ^{a)}	n_{1N} rpm		3400	3400	3400	3400	3400	3400	3400	3400	3400	3400	3400	3400	3400	3400	3400	
Max. input speed	n_{1Max} rpm		6000	6000	6000	6000	6000	6000	6000	6000	6000	6000	6000	6000	6000	6000	6000	
Mean no load running torque (with $n_1=3000$ rpm and 20°C gearhead temperature)	T_{012}	Nm	0.6	0.6	0.5	0.4	0.4	0.3	0.3	0.3	0.3	0.3	0.3	0.3	0.3	0.3	0.3	
		in.lb	5.3	4.9	4.4	3.5	3.4	2.7	2.7	2.7	2.7	2.7	2.7	2.7	2.7	2.2	2.2	
Max. torsional backlash	j_t arcmin	≤ 8					≤ 10											
Torsional rigidity	C_{t21}	Nm/arcmin	20	20	14	14	12	20	20	20	20	14	20	20	14	14	12	
		in.lb/arcmin	180	180	120	120	110	180	180	180	180	120	180	180	120	120	110	
Max. axial force ^{b)}	F_{2AMax}	N	1900					1900										
		lb _f	430					430										
Max. radial force ^{c)}	F_{2RMax}	N	4300					4300										
		lb _f	970					970										
Efficiency at full load	η %	97					95											
Service life (For calculation, see the Chapter "Information")	L_h h	> 20000					> 20000											
Weight incl. standard adapter plate	<i>m</i>	kg	3.3					4.3										
		lb _m	7.3					10										
Operating noise for $i=10$ and $n_1=3000$ rpm without load	L_{PA} dB(A)	≤ 66																
Max. permitted housing temperature	°C	+90																
	F	194																
Ambient temperature	°C	-15 to +40																
	F	5 to 104																
Lubrication	Lubricated for life																	
Paint	Blue RAL 5002																	
Direction of rotation	Motor and gearhead same direction																	
Protection class	IP 64																	
Moment of inertia (relates to the drive)	G	24	J_f	kgcm ²	1.8	1.6	1.5	1.5	1.4	1.5	1.5	1.6	1.6	1.5	1.5	1.4	1.4	1.4
				10 ⁻³ in.lb.s ²	1.6	1.4	1.4	1.3	1.3	1.3	1.3	1.4	1.4	1.3	1.3	1.3	1.3	1.3
Clamping hub diameter (mm)	H	28	J_f	kgcm ²	2	1.9	1.8	1.8	1.7	1.8	1.8	1.9	1.9	1.8	1.8	1.7	1.7	1.7
				10 ⁻³ in.lb.s ²	1.9	1.7	1.6	1.6	1.5	1.6	1.6	1.6	1.6	1.6	1.6	1.5	1.5	1.5

^{a)} For higher ambient temperatures, please reduce input speed

^{b)} Based on the center of the output flange at $n_2 = 100$ rpm

^{c)} With mounted PLPB+ belt pulley and 100 rpm

^{d)} Other ratios are available on request: $i = 15, 21, 28$ and 35 .

LPB+ 1-stage:

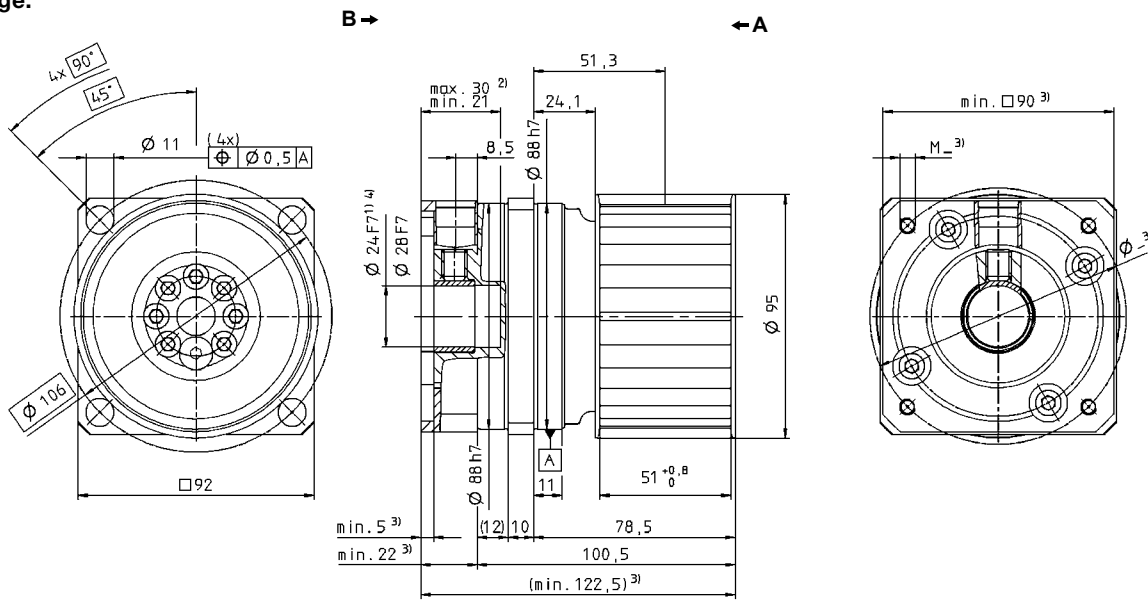

LPB+ 2-stage:

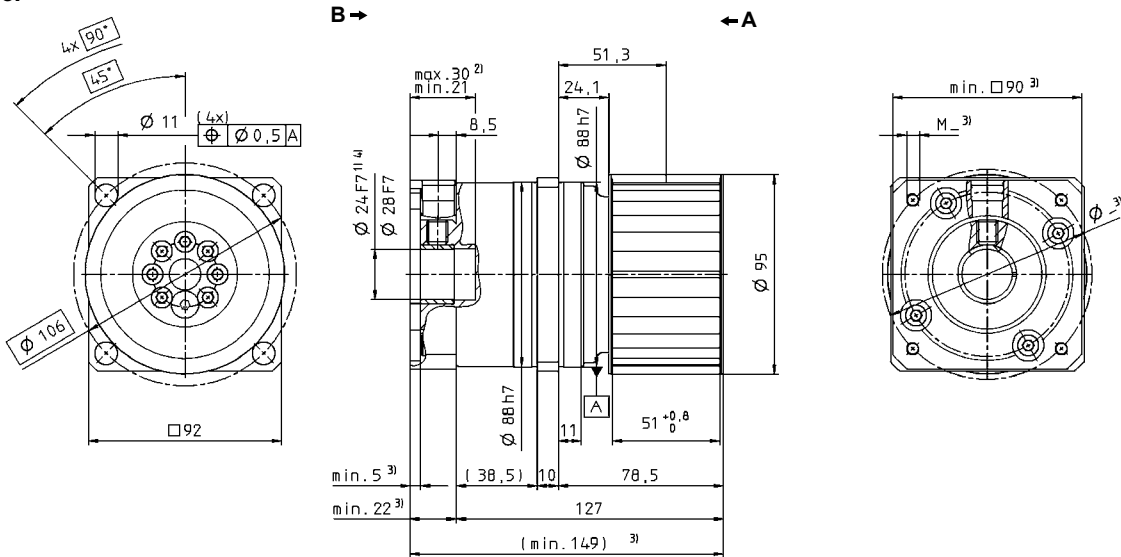

Supplement: Belt pulley PLPB+ (not included in the scope of delivery – please order separately)

Illustration: Output flange without belt pulley

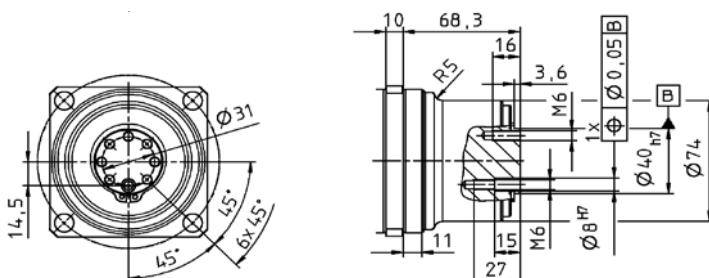

Belt Pulley PLPB+ 090 Profile AT10-0			
Pitch	p	mm	10
Number of teeth	z		28
Circumference	$z * p$	mm/rotation	280
Inertia	J	kgcm ²	10.95
Mass	m	kg	0.82

Non-tolerated dimensions ±1mm

- 1) Check motor shaft fit.
- 2) Min./Max. permissible motor shaft length. Longer motor shafts are adaptable, please contact us.
- 3) The dimensions depend on the motor.
- 4) Smaller motor shaft diameter is compensated by a bushing. Motor shaft diameters up to 28mm available – please contact WITTENSTEIN alpha

CAD data is available under www.wittenstein-alpha.com

Motor mounting according to operating manual

Planetary gearheads
Economy

LPB+
Generation 3

LPB+ 120 MF 1/2-stage

			1-stage					2-stage										
Ratio ^{d)}	<i>i</i>		3	4	5	7	10	9	12	16	20	25	30	40	50	70	100	
Max. acceleration torque (max. 1000 cycles per hour)	T_{2B}	Nm	305	305	250	250	220	305	305	305	305	250	305	305	250	250	220	
		in.lb	2700	2700	2210	2210	1950	2700	2700	2700	2700	2210	2700	2700	2210	2210	1950	
Nominal output torque (with n_m)	T_{2N}	Nm	155	155	125	125	110	155	155	155	155	125	155	155	125	125	110	
		in.lb	1370	1370	1110	1110	970	1370	1370	1370	1370	1110	1370	1370	1110	1110	970	
Emergency stop torque (permitted 1000 times during the service life of the gearhead)	T_{2Not}	Nm	400	480	480	480	480	480	480	480	480	480	480	480	480	480	480	
		in.lb	3540	4250	4250	4250	4250	4250	4250	4250	4250	4250	4250	4250	4250	4250	4250	
Nominal input speed (with T_{2N} and 20°C ambient temperature) ^{a)}	n_{1N} rpm		2600	2600	2600	2600	2600	2600	2600	2600	2600	2600	2600	2600	2600	2600	2600	
Max. input speed	n_{1Max} rpm		4800	4800	4800	4800	4800	4800	4800	4800	4800	4800	4800	4800	4800	4800	4800	
Mean no load running torque (with $n_1=3000$ rpm and 20°C gearhead temperature)	T_{012}	Nm	1.1	1.0	0.9	0.8	0.8	0.6	0.6	0.6	0.5	0.5	0.4	0.5	0.4	0.4	0.4	
		in.lb	9.7	8.9	8.0	7.1	7.1	5.3	5.3	4.9	4.4	4.4	3.5	4.4	3.5	3.5	3.5	
Max. torsional backlash	j_t arcmin	≤ 8					≤ 10											
Torsional rigidity	C_{t21}	Nm/arcmin	47	47	36	36	30	47	47	47	47	36	47	47	36	36	30	
		in.lb/arcmin	420	420	320	320	270	420	420	420	420	320	420	420	320	320	270	
Max. axial force ^{b)}	F_{2AMax}	N	4000					4000										
		lb _f	900					900										
Max. radial force ^{c)}	F_{2RMax}	N	9500					9500										
		lb _f	2140					2140										
Efficiency at full load	η %	97					95											
Service life (For calculation, see the Chapter "Information")	L_h h	> 20000					> 20000											
Weight incl. standard adapter plate	<i>m</i>	kg	7.3					9.7										
		lb _m	16					21										
Operating noise for $i=10$ and $n_1=3000$ rpm without load	L_{PA} dB(A)	≤ 68																
Max. permitted housing temperature	°C	+90																
	F	194																
Ambient temperature	°C	-15 to +40																
	F	5 to 104																
Lubrication	Lubricated for life																	
Paint	Blue RAL 5002																	
Direction of rotation	Motor and gearhead same direction																	
Protection class	IP 64																	
Moment of inertia (relates to the drive)	<i>I</i>	32	J_f	kgcm ²	6.8	5.9	5.6	5.2	5.1	5.4	5.4	5.5	5.5	5.3	5.3	5.0	5.0	5.0
				10 ⁻³ in.lb.s ²	6.1	5.2	4.9	4.6	4.5	4.7	4.7	4.9	4.9	4.7	4.7	4.4	4.4	4.4
Clamping hub diameter (mm)	<i>K</i>	38	J_f	kgcm ²	7.7	6.8	6.4	6.1	5.9	6.2	6.2	6.4	6.4	6.2	6.2	5.9	5.9	5.9
				10 ⁻³ in.lb.s ²	6.8	6.0	5.7	5.4	5.2	5.5	5.5	5.7	5.7	5.5	5.5	5.2	5.2	5.2

^{a)} For higher ambient temperatures, please reduce input speed

^{b)} Based on the center of the output flange at $n_2 = 100$ rpm

^{c)} With mounted PLPB+ belt pulley and 100 rpm

^{d)} Other ratios are available on request: $i = 28$.

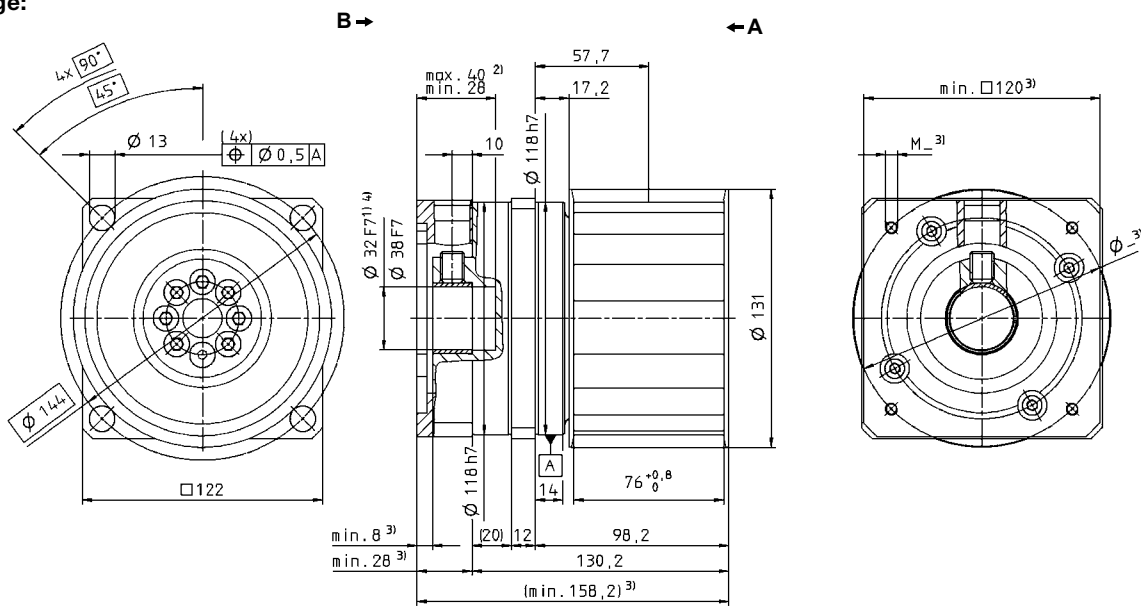
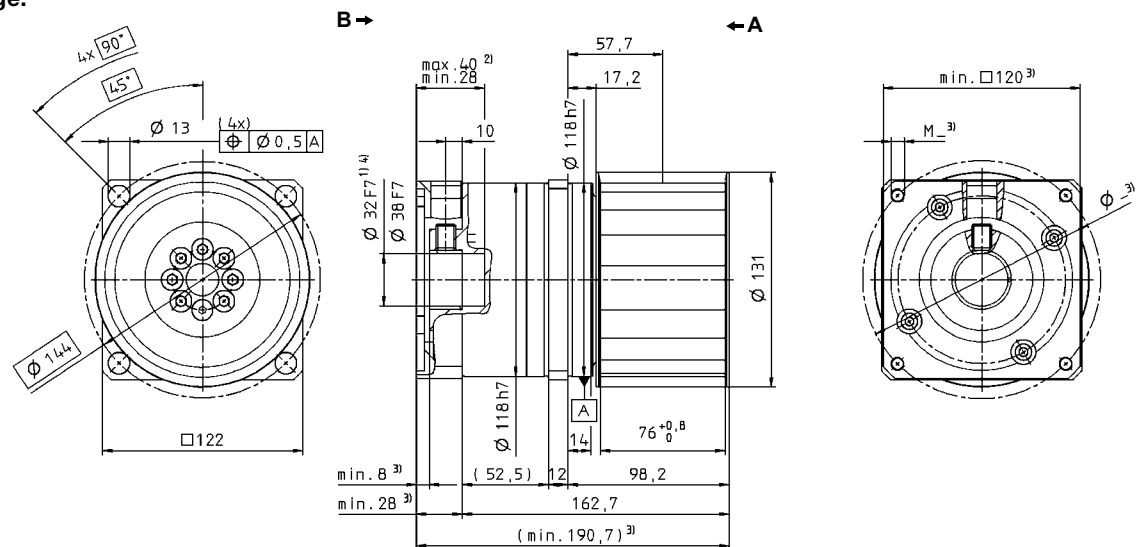
LPB⁺ 1-stage:LPB⁺ 2-stage:

Supplement: Belt pulley PLPB⁺ (not included in the scope of delivery – please order separately)

Illustration: Output flange without belt pulley

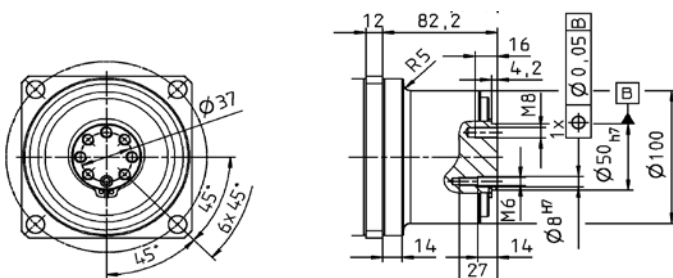

Belt Pulley PLPB ⁺ 120 Profile AT20-0			
Pitch	p	mm	20
Number of teeth	z		19
Circumference	$z \cdot p$	mm/rotation	380
Inertia	J	kgcm ²	50.62
Mass	m	kg	2.61

Non-tolerated dimensions ± 1 mm

- 1) Check motor shaft fit.
- 2) Min./Max. permissible motor shaft length. Longer motor shafts are adaptable, please contact us.
- 3) The dimensions depend on the motor.
- 4) Smaller motor shaft diameter is compensated by a bushing. Motor shaft diameters up to 38mm available – please contact WITTENSTEIN alpha

CAD data is available under www.wittenstein-alpha.com

Motor mounting according to operating manual