

Value Linear Systems from WITTENSTEIN alpha –
flexible all-rounders in the Value Segment

The Value Linear System with **NPR** for use e.g. in plasma cutting systems, water jet cutting systems, simple laser cutting machines or even pipe bending machines with up to 8,000 N/drive train.

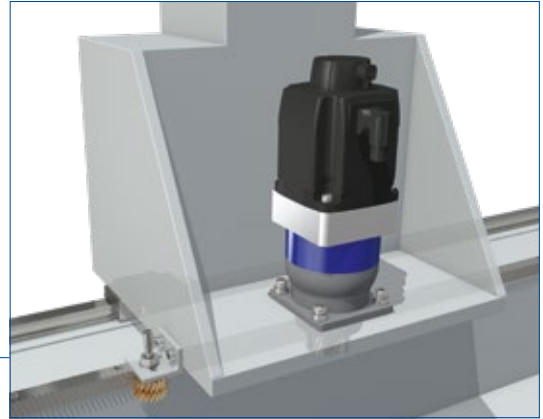

The Value Linear System with **NPR** and **NVS** are used in automation portals, welding robots, pick and place robots, 7th axis, etc.

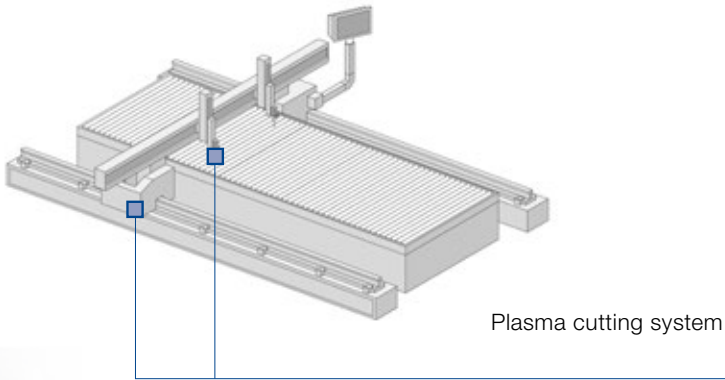
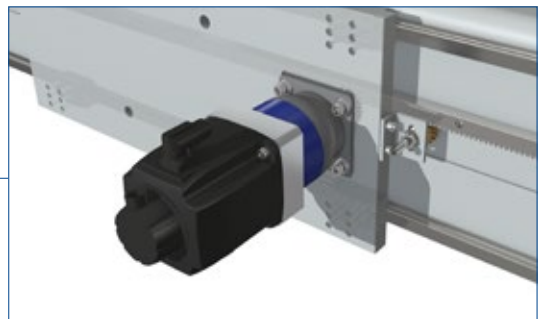
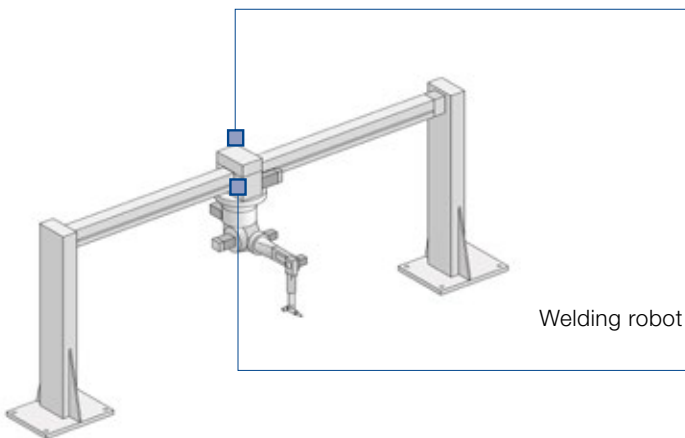

with NPR

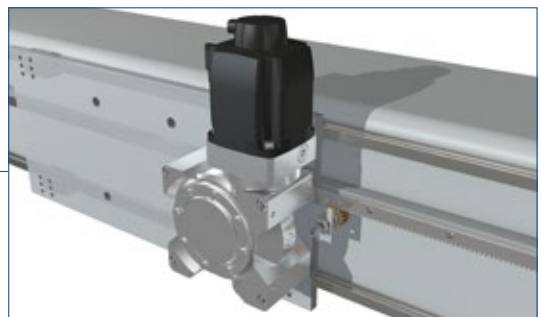

with NVS

The flexible all-rounder in the Value Segment

The Value Linear System is adapted to linear applications in the Value Segment with comparatively low requirements in terms of smooth running, positioning accuracy and feed force. The R-flange of the Premium Segment now allows greater design freedom in the Value Segment.

Your benefits in detail

- **Integrated R-flange for simple design and assembly**
- **Perfectly adapted to the Value Line systems**
- **Available with NVS worm gear**

	Value Linear System	Max. feed force [N]	Max. feed speed [m/min]
with NPR	VLS 2	1890	253
	VLS 3	3220	342
	VLS 4	4300	347
	VLS 6	6150	400
	VLS 8	8000	160

Feed force and feed speed dependent on ratio



NPR

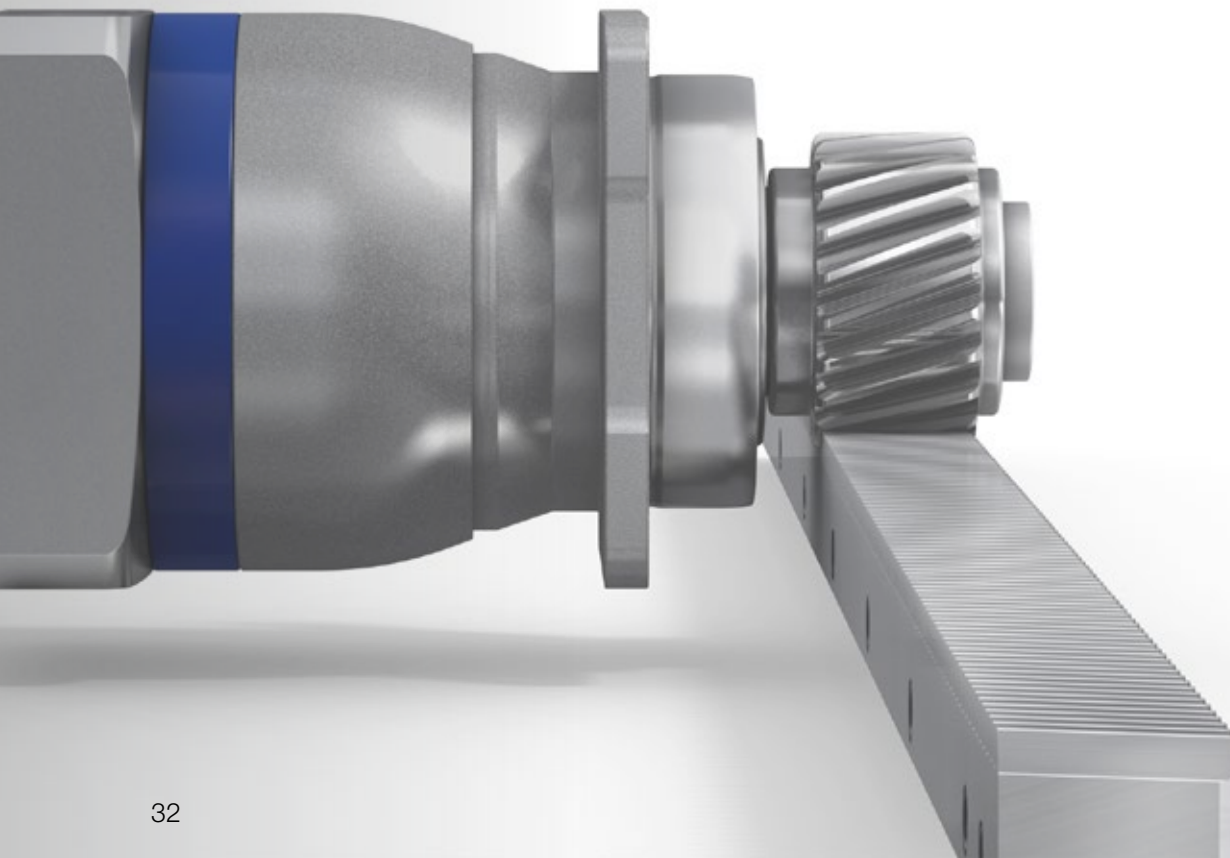

Quick system selection

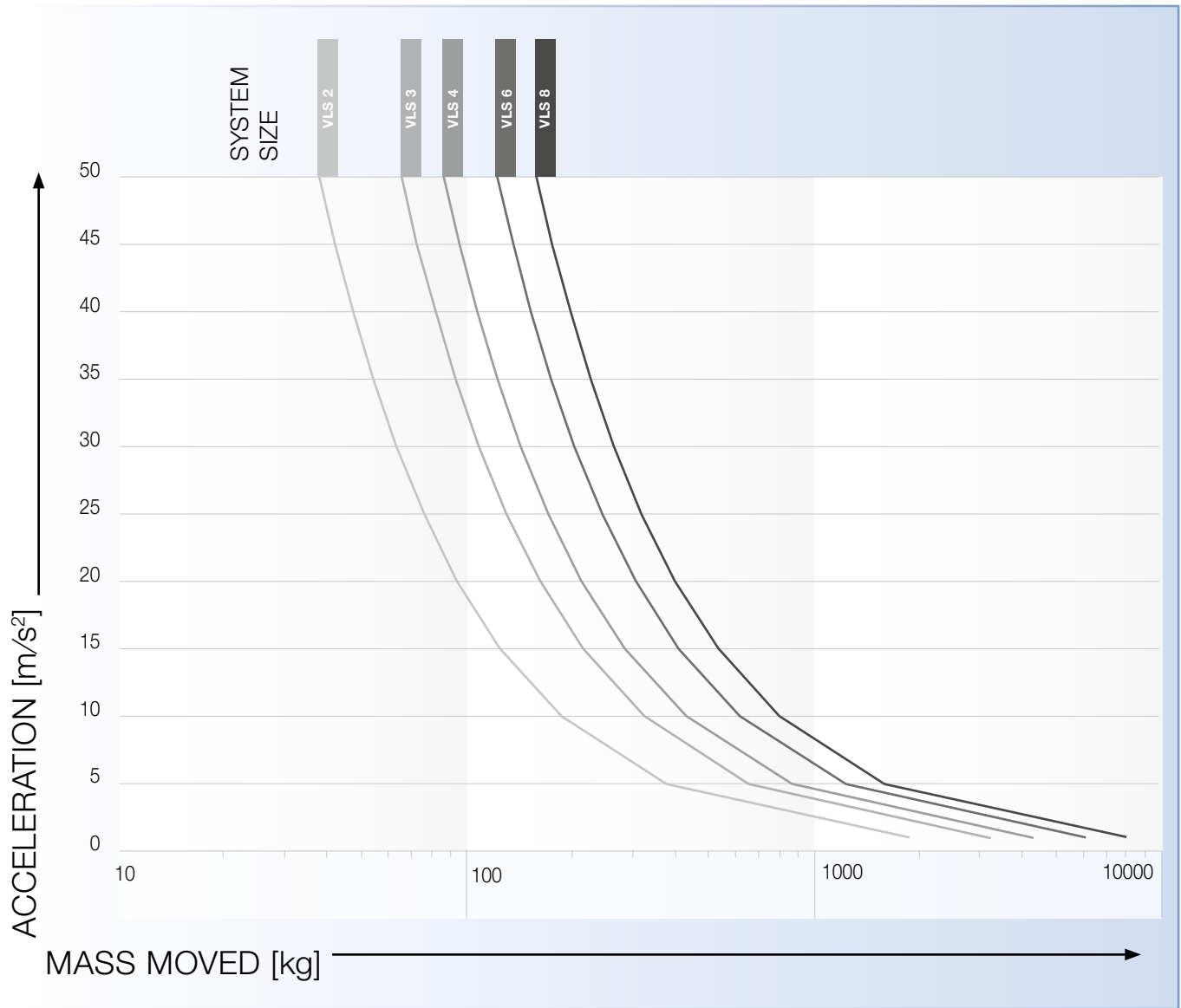

Value Linear Systems overview

Our preferred linear systems are always comprised of the perfect combination of gearbox, pinion, rack and lubrication system. The systems are optimized to achieve the required feed force, feed speed, rigidity and degree of utilization of the individual components. Depending on your individual requirements, you have the option to further configure products via the ordering code. For a detailed dimensioning and configuration of the products we recommend to use cymex® 5.

System	Gearbox	Pinion	Rack
VLS 2	NPR 015S	RMK 150-222-19L1-016	ZST 150-221-1000-R1
VLS 3	NPR 025S	RMK 200-222-22L1-022	ZST 200-221-1000-R1
VLS 4	NPR 035S	RMK 200-222-26L1-032	ZST 200-221-1000-R1
VLS 6	NPR 035S	RMS 300-323-20L1-032	ZST 300-221-1000-R1
VLS 8	NPR 045S	RMS 300-323-20L1-040	ZST 300-221-1000-R1



Assembly accessories can be found starting at page 128 and information on the lubrication system starting at page 116

Ordering code

Gearbox*

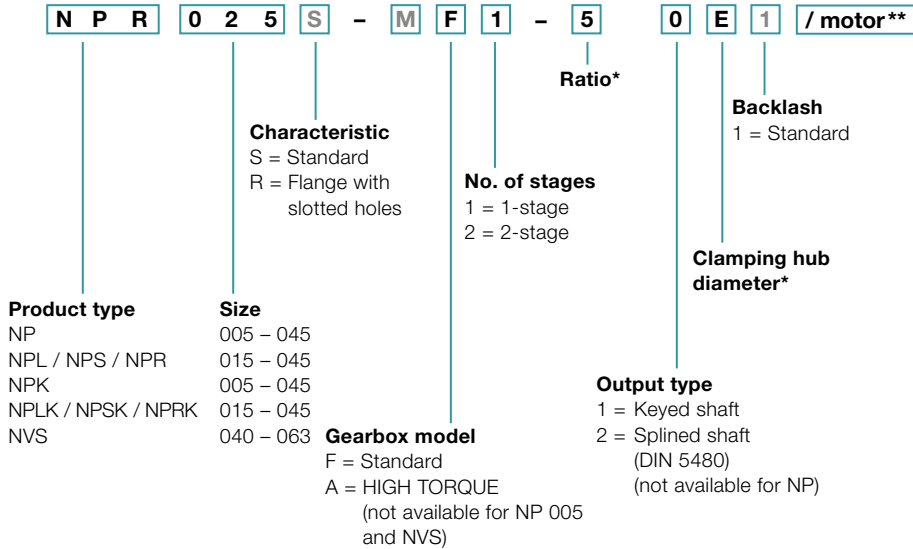

M Components with a gray font cannot be selected

* Further information about the gearboxes is available in the respective catalogs, at www.wittenstein-alpha.com or on request

** Full motor designation only required to determine gearbox mounting parts

Rack

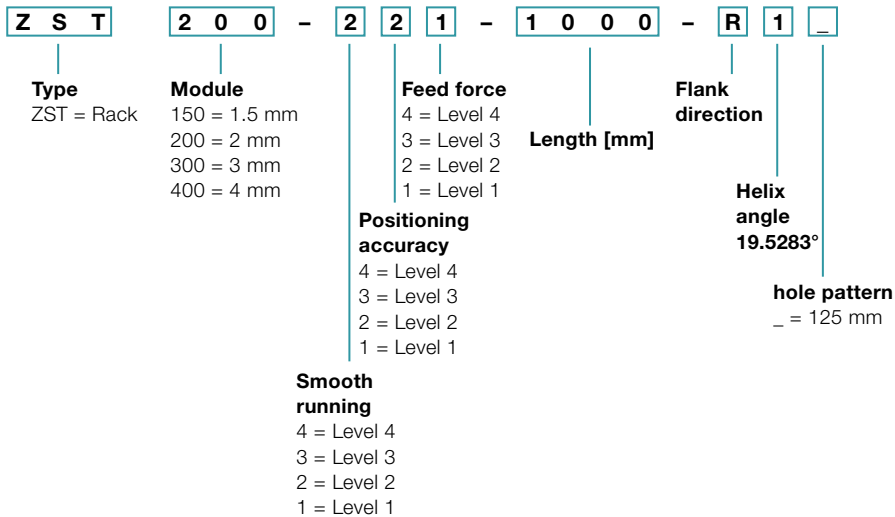

Pinion

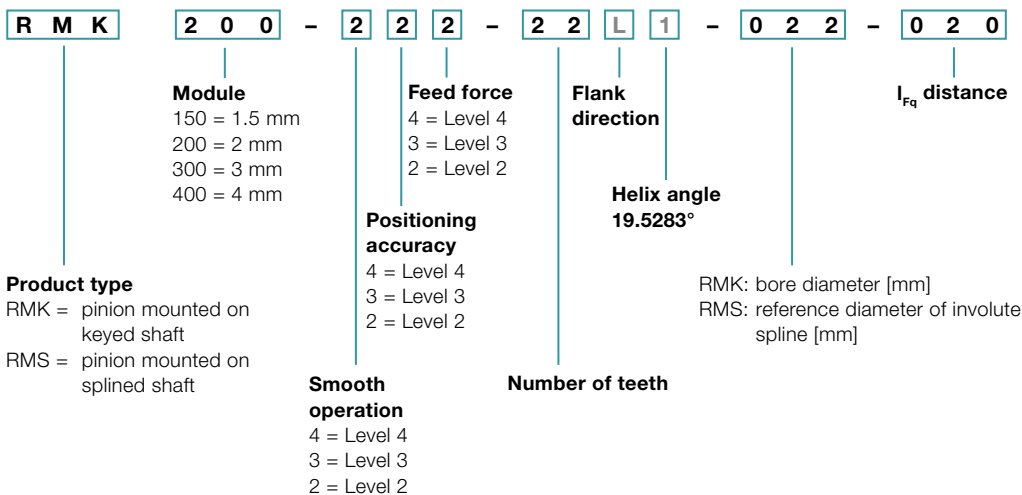

Value Linear System VLS 2 with NPR

Planetary gearbox NPR 015 MF with rack module 1.5 and pinion RMK module 1.5

System	Max. feed force ¹⁾ F_{zT}		1890 N	
	Max. feed speed ²⁾ v_{max}		253 m/min	79 m/min
Gearbox	No. of stages		1	2
	Ratios i		3 / 4 / 5 / 7 / 8 / 10	12 / 15 / 16 / 20 / 25 / 28 / 30 / 32 / 35 / 40 / 50 / 64 / 70 / 100
	Clamping hub diameter		9 / 11 / 14 / 16 / 19 mm	8 / 9 / 11 / 14 mm
	Designation		NPR 015S-MF1-_-_-1_-_-	NPR 015S-MF2-_-_-1_-_-
Pinion	Module m		1.5 mm	
	Number of teeth z		19	
	Pitch circle diameter d		30.239 mm	
	Profile correction factor x		0.3	
	Helix angle β		-19.5283° (left-handed)	
	Designation		RMK 150-222-19L1-016-022	
Rack	Module m		1.5 mm	
	Lengths L		1000 mm	
	Helix angle β		19.5283° (right-handed)	
	Designation		ZST 150-221-1000-R1	
Lubrication system ³⁾	Set consisting of lubrication pinion and axis for	Rack	LMT 150-PU -24L1-020-1	
		Pinion	LMT 150-PU -24R1-020-1	
	Lubricator	125 cm ³	LUC+125-0511-02	
		400 cm ³	LUC+400-0511-02	
	Lubricant		WITTENSTEIN alpha G11	

¹⁾ Maximum feed force depending on ratio and number of stages

²⁾ Calculation with lowest ratio and maximum input speed

³⁾ Impulse-controlled basic version with one output and 2 m hose. See page 116 for further information on the lubrication system.
Application-specific dimensioning with cymex® – www.wittenstein-cymex.com

Alternative system solutions

Pinion			Axis distance	NPS/ NPL/ NPR 015S	NP 015S	NPSK/ NPLK/ NPRK 015S	NPK 015S	NVS 040	Rack
Designation	d [mm]	x []	A [mm]	F_{zT} [N]	F_{zT} [N]	F_{zT} [N]	F_{zT} [N]	F_{zT} [N]	Designation
RMK 150-222-19L1-016-022	30.239	0.3	33.070	1890	1290	1890	1290	1890	ZST 150-221-1000-R1
RMK 200-222-18L1-016-019	38.197	0.4	41.899	2080	1330	2080	1330	2230	ZST 200-221-1000-R1
RMS 200-323-15L1-016	31.831	0.5	38.916	2240	-	2240	-	-	ZST 200-221-1000-R1
RMS 200-323-16L1-016	33.953	0.5	39.977	2220	-	2220	-	-	ZST 200-221-1000-R1
RMS 200-323-18L1-016	38.197	0.4	41.899	2080	-	2080	-	-	ZST 200-221-1000-R1

d = Pitch circle diameter

x = Addendum modification coefficient

A = Distance between pinion axle and rear surface of rack

F_{zT} = Maximum feed force depending on ratio and number of stages

Application-specific dimensioning with cymex® – www.wittenstein-cymex.com

1-stage

up to 14⁴⁾ (C)
clamping hub
diameters

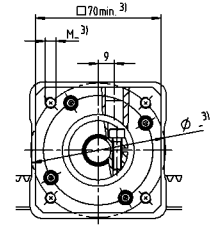
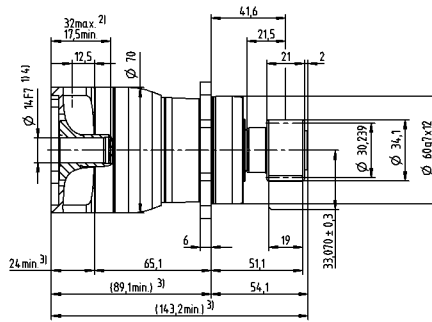
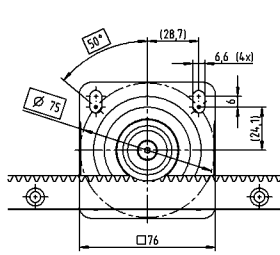

up to 19⁴⁾ (E)
clamping hub
diameters

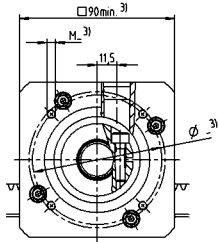
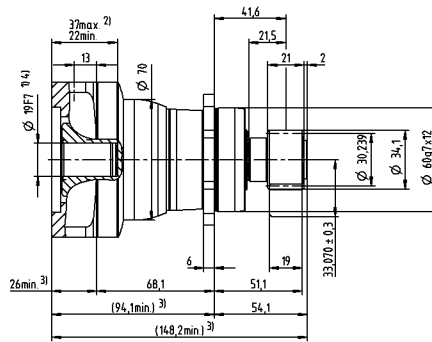
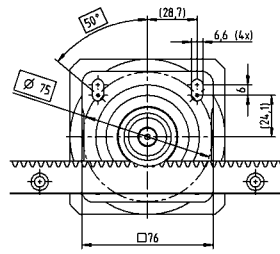

2-stage

up to 11⁴⁾ (B)
clamping hub
diameters

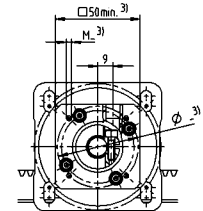
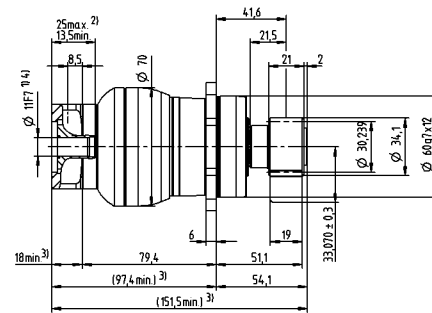
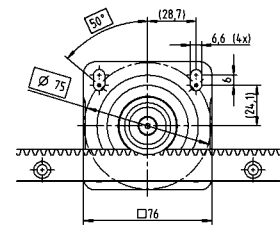

up to 14⁴⁾ (C)
clamping hub
diameter

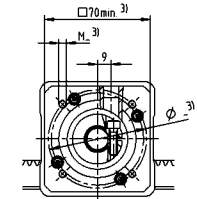
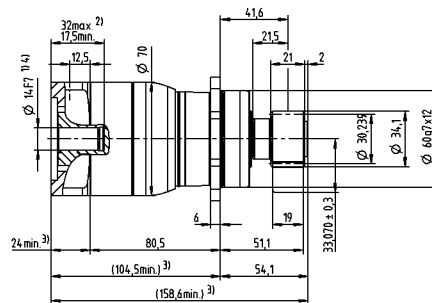
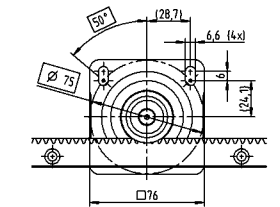

Motor shaft diameter [mm]

Non-tolerated dimensions are nominal dimensions
Detailed rack dimensions starting on page 151
1) Check motor shaft fit
2) Min./Max. permissible motor shaft length. Longer motor shafts are possible, please contact alpha.
3) The dimensions depend on the motor
4) Smaller motor shaft diameter is compensated by a bushing with a minimum thickness of 1 mm

Value Linear System VLS 3 with NPR

Planetary gearbox NPR 025 MF with rack module 2 and pinion RMK module 2

System	Max. feed force ¹⁾ F_{2T}		3220 N	
	Max. feed speed ²⁾ v_{max}		342 m/min	130 m/min
Gearbox	No. of stages		1	2
	Ratios i		3 / 4 / 5 / 7 / 8 / 10	9 / 12 / 15 / 16 / 20 / 25 / 28 / 30 / 32 / 35 / 40 / 50 / 64 / 70 / 100
	Clamping hub diameter		14 / 16 / 19 / 24 / 28 mm	9 / 11 / 14 / 16 / 19 mm
	Designation		NPR 025S-MF1-_-_-1_-_-	NPR 025S-MF2-_-_-1_-_-
Pinion	Module m		2 mm	
	Number of teeth z		22	
	Pitch circle diameter d		46.686 mm	
	Profile correction factor x		0.2	
	Helix angle β		-19.5283° (left-handed)	
	Designation		RMK 200-222-22L1-022-020	
Rack	Module m		2 mm	
	Lengths L		1000 mm	
	Helix angle β		19.5283° (right-handed)	
	Designation		ZST 200-221-1000-R1	
Lubrication system ³⁾	Set consisting of lubrication pinion and axis for	Rack	LMT 200-PU -18L1-024-1	
		Pinion	LMT 200-PU -18R1-024-1	
	Lubricator	125 cm ³	LUC+125-0511-02	
		400 cm ³	LUC+400-0511-02	
	Lubricant		WITTENSTEIN alpha G11	

¹⁾ Maximum feed force depending on ratio and number of stages

²⁾ Calculation with lowest ratio and maximum input speed

³⁾ Impulse-controlled basic version with one output and 2 m hose. See page 116 for further information on the lubrication system.
Application-specific dimensioning with cymex® – www.wittenstein-cymex.com

Alternative system solutions

Pinion			Axis distance	NPS/ NPL/ NPR 025S	NP 025S	NPSK/ NPLK/ NPRK 025S	NPK 025S	NVS 050	Rack
Designation	d [mm]	x []	A [mm]	F_{2T} [N]	F_{2T} [N]	F_{2T} [N]	F_{2T} [N]	F_{2T} [N]	Designation
RMK 200-222-22L1-022-020	46.686	0.2	45.743	3220	2350	3220	2340	3530	ZST 200-221-1000-R1
RMS 200-323-18L1-022	38.197	0.4	41.899	3430	–	3430	–	–	ZST 200-221-1000-R1
RMS 200-323-20L1-022	42.441	0.4	44.021	3250	–	3250	–	–	ZST 200-221-1000-R1
RMS 200-323-22L1-022	46.686	0.4	46.143	3220	–	3220	–	–	ZST 200-221-1000-R1

d = Pitch circle diameter

x = Addendum modification coefficient

A = Distance between pinion axle and rear surface of rack

F_{2T} = Maximum feed force depending on ratio and number of stages

Application-specific dimensioning with cymex® – www.wittenstein-cymex.com

1-stage

up to 19⁴⁾ (E)
clamping hub
diameters

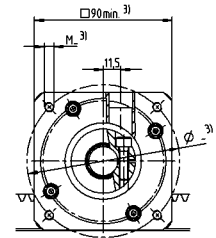
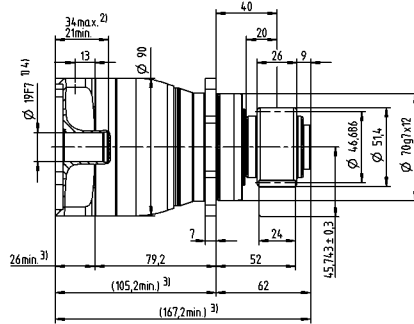
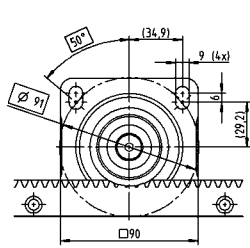

up to 28⁴⁾ (H)
clamping hub
diameters

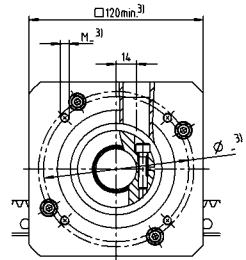
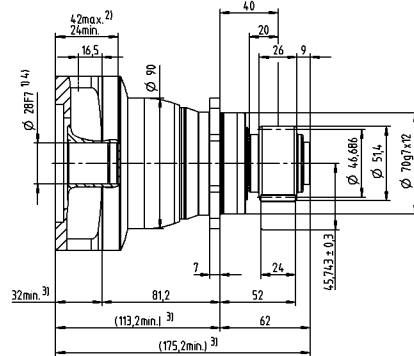
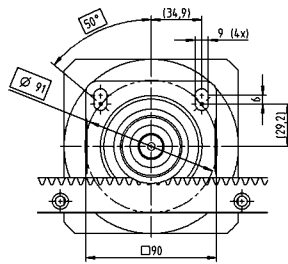

2-stage

up to 14⁴⁾ (C)
clamping hub
diameters

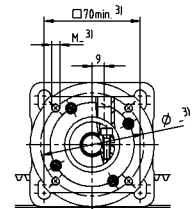
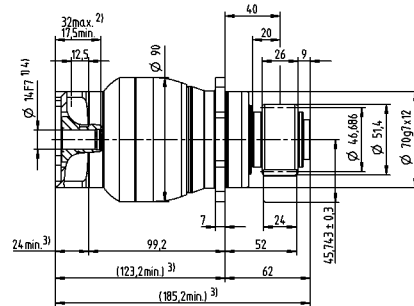
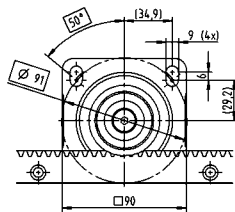

up to 19⁴⁾ (E)
clamping hub
diameters

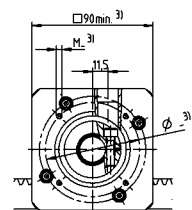
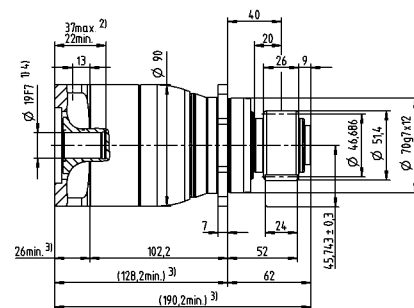
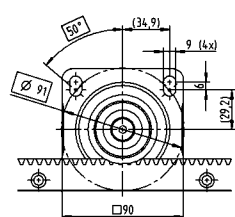

Motor shaft diameter [mm]

Non-tolerated dimensions are nominal dimensions
Detailed rack dimensions starting on page 151

¹⁾ Check motor shaft fit

²⁾ Min./Max. permissible motor shaft length. Longer motor shafts are possible, please contact alpha.

³⁾ The dimensions depend on the motor

⁴⁾ Smaller motor shaft diameter is compensated by a bushing with a minimum thickness of 1 mm

Value Linear System VLS 4 with NPR

Planetary gearbox NPR 035 MF with rack module 2 and pinion RMK module 2

System	Max. feed force ¹⁾ F_{2T}		4300 N	
	Max. feed speed ²⁾ v_{max}		347 m/min	135 m/min
Gearbox	No. of stages		1	2
	Ratios i		3 / 4 / 5 / 7 / 8 / 10	9 / 12 / 15 / 16 / 20 / 25 / 28 / 30 / 32 / 35 / 40 / 50 / 64 / 70 / 100
	Clamping hub diameter		19 / 24 / 28 / 32 / 38 mm	14 / 16 / 19 / 24 / 28 mm
	Designation		NPR 035S-MF1-_-_-1_-_-	NPR 035S-MF2-_-_-1_-_-
Pinion	Module m		2 mm	
	Number of teeth z		26	
	Pitch circle diameter d		55.174 mm	
	Profile correction factor x		0	
	Helix angle β		-19.5283° (left-handed)	
	Designation		RMK 200-222-26L1-032-021	
Rack	Module m		2 mm	
	Lengths L		1000 mm	
	Helix angle β		19.5283° (right-handed)	
	Designation		ZST 200-221-1000-R1	
Lubrication system ³⁾	Set consisting of lubrication pinion and axis for	Rack	LMT 200-PU -18L1-024-1	
		Pinion	LMT 200-PU -18R1-024-1	
	Lubricator	125 cm ³	LUC+125-0511-02	
		400 cm ³	LUC+400-0511-02	
	Lubricant		WITTENSTEIN alpha G11	

¹⁾ Maximum feed force depending on ratio and number of stages

²⁾ Calculation with lowest ratio and maximum input speed

³⁾ Impulse-controlled basic version with one output and 2 m hose. See page 116 for further information on the lubrication system.
Application-specific dimensioning with cymex® – www.wittenstein-cymex.com

Alternative system solutions

Pinion			Axis distance	NPS/ NPL/ NPR 035S	NP 035S	NPSK/ NPLK/ NPRK 035S	NPK 035S	NVS 063	Rack
Designation	d [mm]	x []	A [mm]	F_{2T} [N]	F_{2T} [N]	F_{2T} [N]	F_{2T} [N]	F_{2T} [N]	Designation
RMK 200-222-26L1-032-021	55.174	0	49.587	4300	4300	4300	4300	4300	ZST 200-221-1000-R1
RMS 200-323-23L1-032	48.808	0.4	47.204	4300	–	4300	–	–	ZST 200-221-1000-R1
RMS 200-323-25L1-032	53.052	0.4	49.326	4300	–	4300	–	–	ZST 200-221-1000-R1
RMS 200-323-27L1-032	57.296	0.3	51.248	4300	–	4300	–	–	ZST 200-221-1000-R1

d = Pitch circle diameter

x = Addendum modification coefficient

A = Distance between pinion axle and rear surface of rack

F_{2T} = Maximum feed force depending on ratio and number of stages

Application-specific dimensioning with cymex® – www.wittenstein-cymex.com

1-stage

up to 28⁴⁾ (H)
clamping hub
diameters

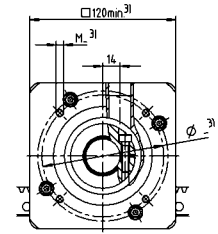
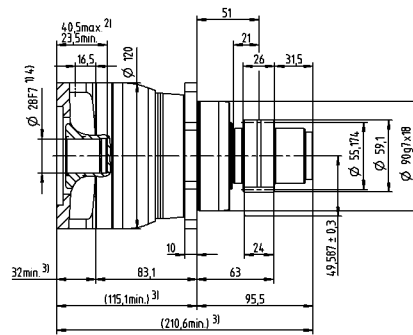
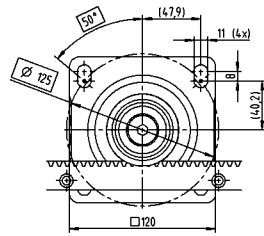

up to 38⁴⁾ (K)
clamping hub
diameters

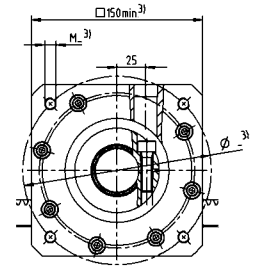
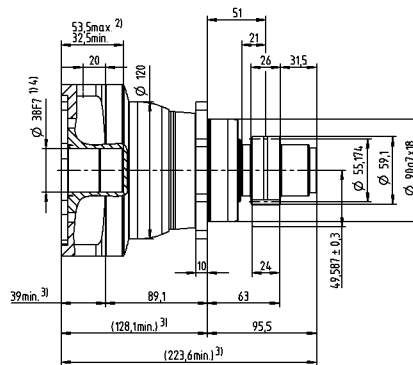
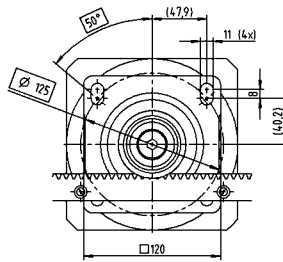

2-stage

up to 19⁴⁾ (E)
clamping hub
diameters

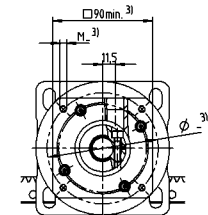
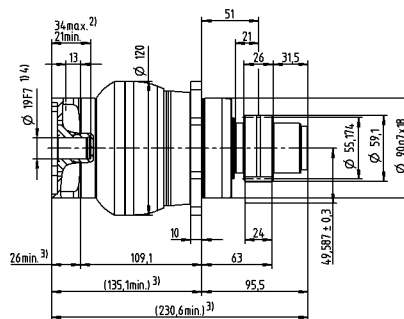
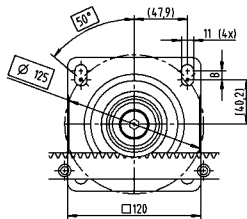

up to 28⁴⁾ (H)
clamping hub
diameters

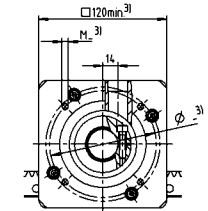
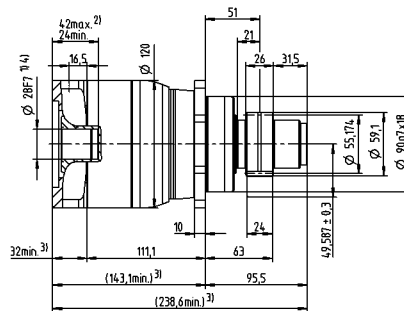
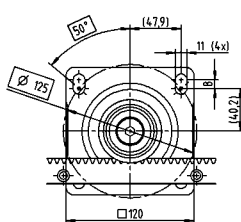

Motor shaft diameter [mm]

Non-olerated dimensions are nominal dimensions
Detailed rack dimensions starting on page 151
1) Check motor shaft fit
2) Min./Max. permissible motor shaft length. Longer motor shafts are possible, please contact alpha.
3) The dimensions depend on the motor
4) Smaller motor shaft diameter is compensated by a bushing with a minimum thickness of 1 mm

Value Linear System VLS 6 with NPR

Planetary gearbox NPR 035 MF with rack module 3 and pinion RMS module 3

System	Max. feed force ¹⁾ F_{zT}	6150 N	
	Max. feed speed ²⁾ v_{max}	400 m/min	156 m/min
Gearbox	No. of stages	1	2
	Ratios i	3 / 4 / 5 / 7 / 8 / 10	9 / 12 / 15 / 16 / 20 / 25 / 28 / 30 / 32 / 35 / 40 / 50 / 64 / 70 / 100
	Clamping hub diameter	19 / 24 / 28 / 32 / 38 mm	14 / 16 / 19 / 24 / 28 mm
	Designation	NPR 035S-MF1-_-_-_-2_-_-	NPR 035S-MF2-_-_-_-2_-_-
Pinion	Module m	3 mm	
	Number of teeth z	20	
	Pitch circle diameter d	63.662 mm	
	Profile correction factor x	0.4	
	Helix angle β	-19.5283° (left-handed)	
	Designation	RMS 300-323-20L1-032	
Rack	Module m	3 mm	
	Lengths L	1000 mm	
	Helix angle β	19.5283° (right-handed)	
	Designation	ZST 300-221-1000-R1	
Lubrication system ³⁾	Set consisting of lubrication pinion and axis for	Rack	LMT 300-PU -18L1-030-1
		Pinion	LMT 300-PU -18R1-030-1
	Lubricator	125 cm ³	LUC+125-0511-02
		400 cm ³	LUC+400-0511-02
	Lubricant	WITTENSTEIN alpha G11	

¹⁾ Maximum feed force depending on ratio and number of stages

²⁾ Calculation with lowest ratio and maximum input speed

³⁾ Impulse-controlled basic version with one output and 2 m hose. See page 116 for further information on the lubrication system.
Application-specific dimensioning with cymex® – www.wittenstein-cymex.com

Alternative system solutions

Pinion			Axis distance	NPS/ NPL/ NPR 035S	NP 035S	NPS/ NPL/ NPR 035S	NP 035S	Rack
Designation	d [mm]	x []	A [mm]	F_{zT} [N]	F_{zT} [N]	F_{zT} [N]	F_{zT} [N]	Designation
RMK 200-222-26L1-032-021	55.174	0	49.587	4300	4300	4300	4300	ZST 200-221-1000-R1
RMS 200-323-23L1-032	48.808	0.4	47.204	4300	–	4300	–	ZST 200-221-1000-R1
RMS 200-323-25L1-032	53.052	0.4	49.326	4300	–	4300	–	ZST 200-221-1000-R1
RMS 200-323-27L1-032	57.296	0.3	51.248	4300	–	4300	–	ZST 200-221-1000-R1
RMS 300-323-20L1-032	63.662	0.4	59.031	6150	–	6150	–	ZST 300-221-1000-R1

d = Pitch circle diameter

x = Addendum modification coefficient

A = Distance between pinion axle and rear surface of rack

F_{zT} = Maximum feed force depending on ratio and number of stages

Application-specific dimensioning with cymex® – www.wittenstein-cymex.com

1-stage

up to 28⁴⁾ (H) clamping hub diameters

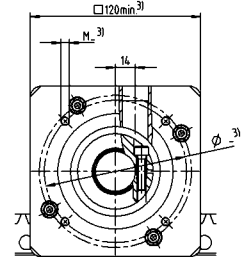
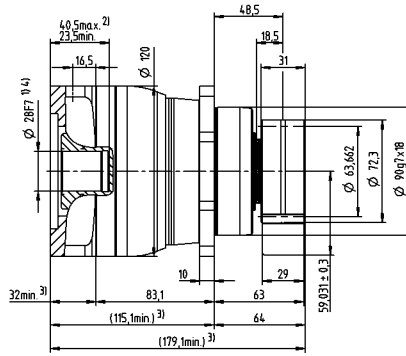
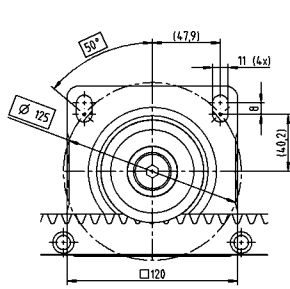

up to 38⁴⁾ (K) clamping hub diameters

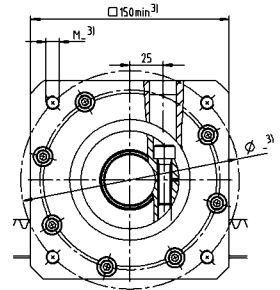
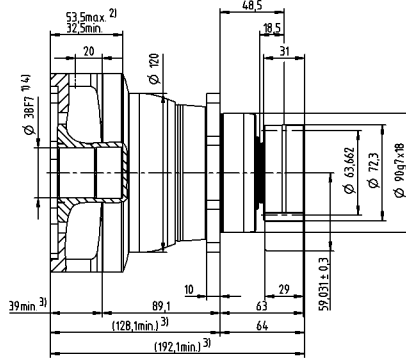
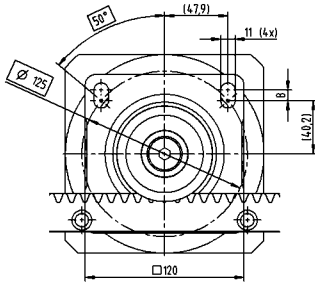

2-stage

up to 19⁴⁾ (E) clamping hub diameters

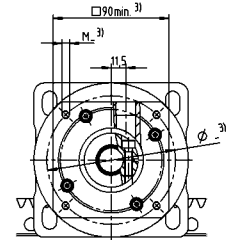
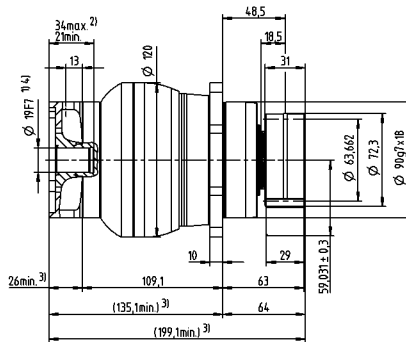
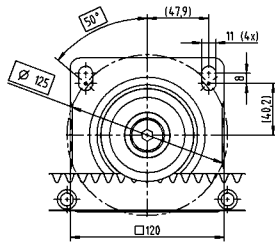

up to 28⁴⁾ (H) clamping hub diameters

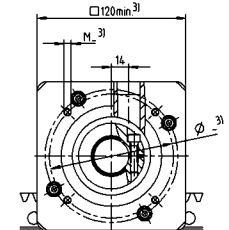
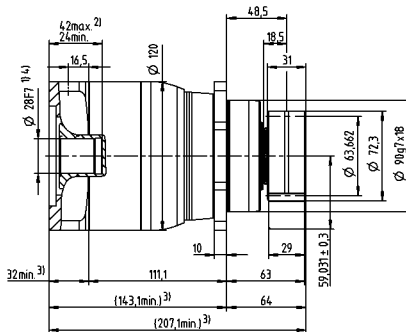
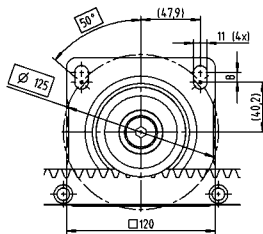

Motor shaft diameter [mm]

Non-tolerated dimensions are nominal dimensions
Detailed rack dimensions starting on page 151

¹⁾ Check motor shaft fit

²⁾ Min./Max. permissible motor shaft length. Longer motor shafts are possible, please contact alpha.

³⁾ The dimensions depend on the motor

⁴⁾ Smaller motor shaft diameter is compensated by a bushing with a minimum thickness of 1 mm

Value Linear System VLS 8 with NPR

Planetary gearbox NPR 045 MF with rack module 3 and pinion RMS module 3

System	Max. feed force ¹⁾ F_{zT}		8000 N	
	Max. feed speed ²⁾ v_{max}		160 m/min	48 m/min
Gearbox	No. of stages		1	2
	Ratios i		5 / 8 / 10	25 / 32 / 50 / 64 / 100
	Clamping hub diameter		38 mm	19 / 24 / 28 / 32 / 38 mm
	Designation		NPR 045S-MF1-_-_-_-2_-_-	NPR 045S-MF2-_-_-_-2_-_-
Pinion	Module m		3 mm	
	Number of teeth z		20	
	Pitch circle diameter d		63.662 mm	
	Profile correction factor x		0.4	
	Helix angle β		-19.5283° (left-handed)	
	Designation		RMS 300-323-20L1-040	
Rack	Module m		3 mm	
	Lengths L		1000 mm	
	Helix angle β		19.5283° (right-handed)	
	Designation		ZST 300-221-1000-R1	
Lubrication system ³⁾	Set consisting of lubrication pinion and axis for	Rack	LMT 300-PU -18L1-030-1	
		Pinion	LMT 300-PU -18R1-030-1	
	Lubricator	125 cm ³	LUC+125-0511-02	
		400 cm ³	LUC+400-0511-02	
	Lubricant		WITTENSTEIN alpha G11	

¹⁾ Maximum feed force depending on ratio and number of stages

²⁾ Calculation with lowest ratio and maximum input speed

³⁾ Impulse-controlled basic version with one output and 2 m hose. See page 116 for further information on the lubrication system.
Application-specific dimensioning with cymex® – www.wittenstein-cymex.com

Alternative system solutions

Pinion			Axis distance	NPS/ NPL/ NPR 045S	NP 045S	NPSK/ NPLK/ NPRK 045S	NPK 045S	Rack
Designation	d [mm]	x []	A [mm]	F_{zT} [N]	F_{zT} [N]	F_{zT} [N]	F_{zT} [N]	Designation
RMK 300-222-24L1-040-035	76.394	0	64.197	8000	7450	8000	7450	ZST 300-221-1000-R1
RMS 300-323-20L1-040	63.662	0.4	59.031	8000	–	8000	–	ZST 300-221-1000-R1
RMS 300-323-22L1-040	70.028	0.4	62.214	8000	–	8000	–	ZST 300-221-1000-R1
RMS 300-323-24L1-040	76.394	0.4	65.397	8000	–	8000	–	ZST 300-221-1000-R1

d = Pitch circle diameter

x = Addendum modification coefficient

A = Distance between pinion axle and rear surface of rack

F_{zT} = Maximum feed force depending on ratio and number of stages

Application-specific dimensioning with cymex® – www.wittenstein-cymex.com

1-stage

up to 38⁴⁾ (K)
clamping hub
diameters

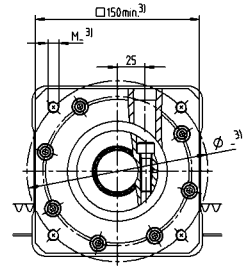
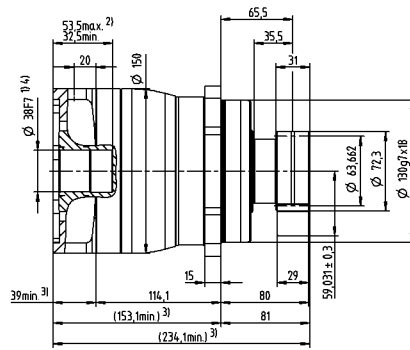
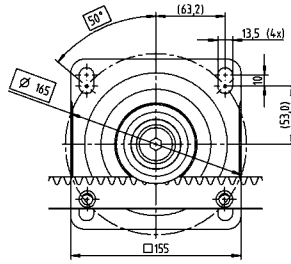

up to 28⁴⁾ (H)
clamping hub
diameters

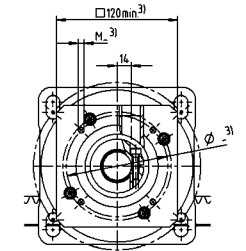
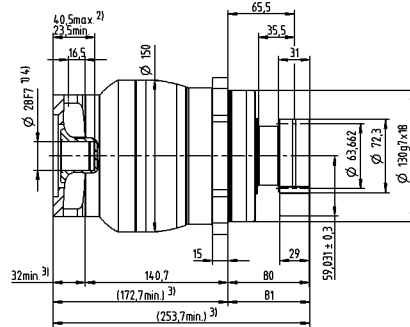
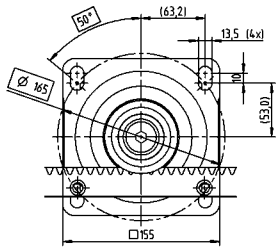

2-stage

up to 38⁴⁾ (K)
clamping hub
diameters

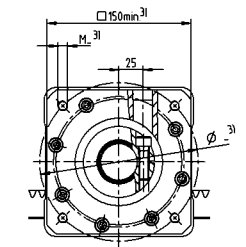
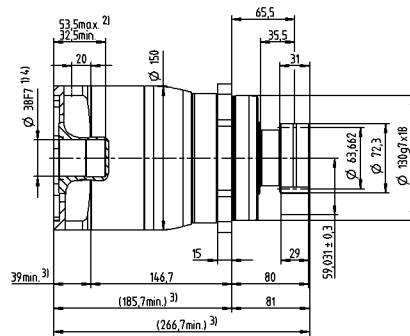
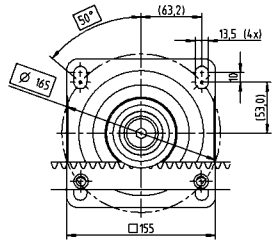

Motor shaft diameter [mm]

Value Linear Systems

Non-tolerated dimensions are nominal dimensions
Detailed rack dimensions starting on page 151
1) Check motor shaft fit
2) Min./Max. permissible motor shaft length. Longer motor shafts are possible, please contact alpha.
3) The dimensions depend on the motor
4) Smaller motor shaft diameter is compensated by a bushing with a minimum thickness of 1 mm