

Premium Linear Systems
from WITTENSTEIN alpha –
Perfection in the application

Premium Linear Systems – the perfect solution for linear feed drives in machine tools and highly dynamic automation solutions

The Premium Linear System with **XP+** and associated right-angle and servo actuator versions is used predominantly as a single drive within a range of up to 10,700 N/drive.

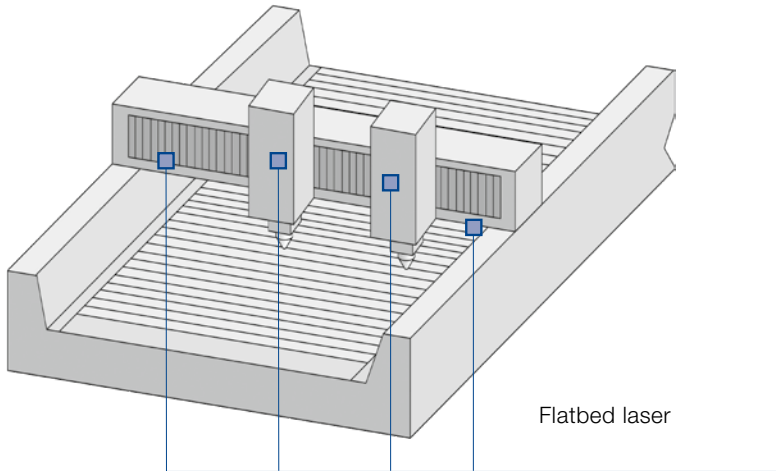

Flatbed laser

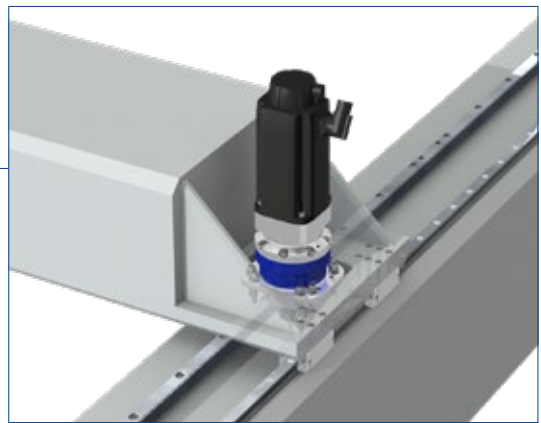

The Premium Linear System with **RP+** and associated right-angle and servo actuator versions is mostly used in an electrically braced master/slave configuration in machine tools, allowing feed forces of up to 113,000 N/drive.

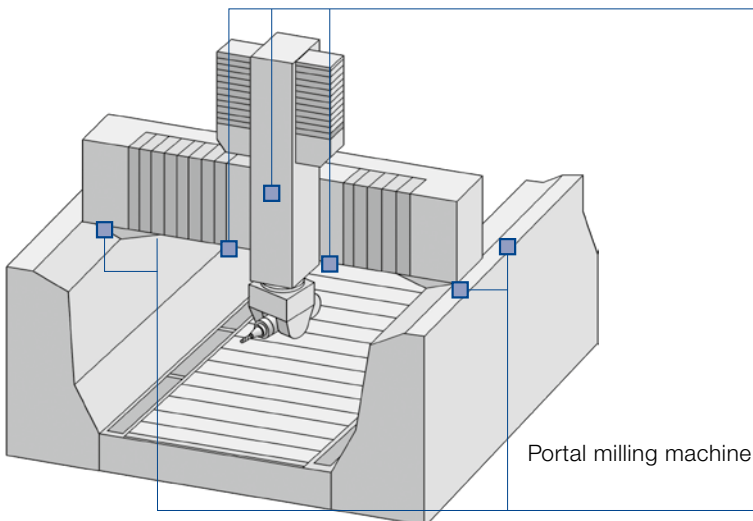

Portal milling machine

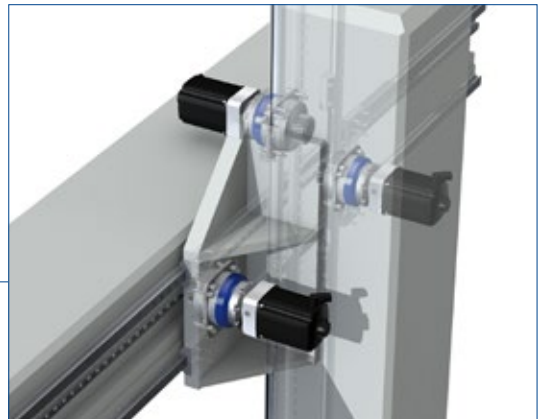

New dimensions in performance

With the Premium Linear System, the performance of the rack and pinion system reaches a new dimension. While others are still busy adapting existing solutions, WITTENSTEIN alpha has stayed several steps ahead with the improved new linear systems. The innovative Premium Linear Systems are used in applications where the individual requirements far exceed what has previously been possible. Compared to the industry standard, the values have been improved by 150 % on average.

Your benefits in comparison to the industry standard

- 150 % Greater feed force
- 100 % Higher power density
- 50 % Greater system reliability
- 50 % Less mounting effort
- 15 % Greater positioning accuracy

	Premium Linear System	Max. feed force [N]	Max. feed speed [m/min]
with XP+	PLS 5	5450	333
	PLS 8	8350	244
	PLS 11	10700	333
with RP+	PLS 10	9750	133
	PLS 13	12900	200
	PLS 20	20300	250
	PLS 22	22300	104
	PLS 36	36100	112
	PLS 47	47000	135
	PLS 75	75000	91
	PLS 112	112000	111

Feed force and feed speed dependent on ratio



XP+



RP+

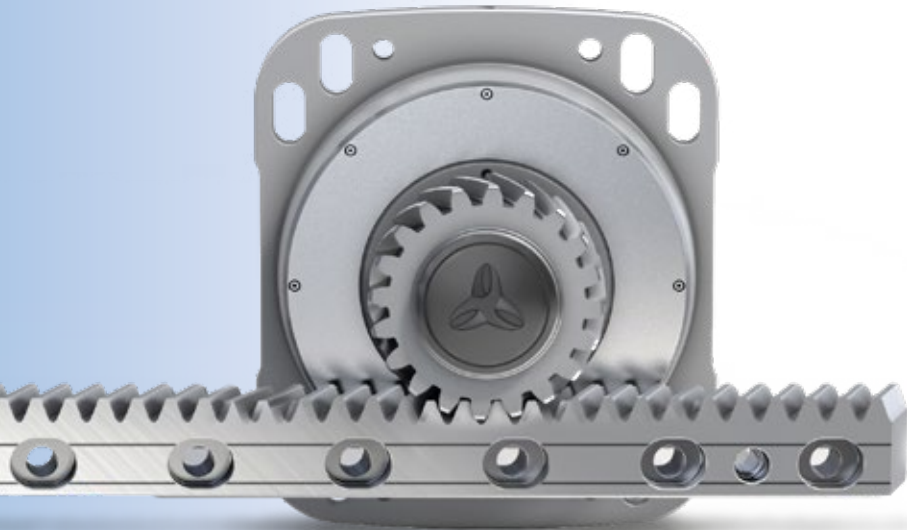

Quick system selection

XP+

RP+

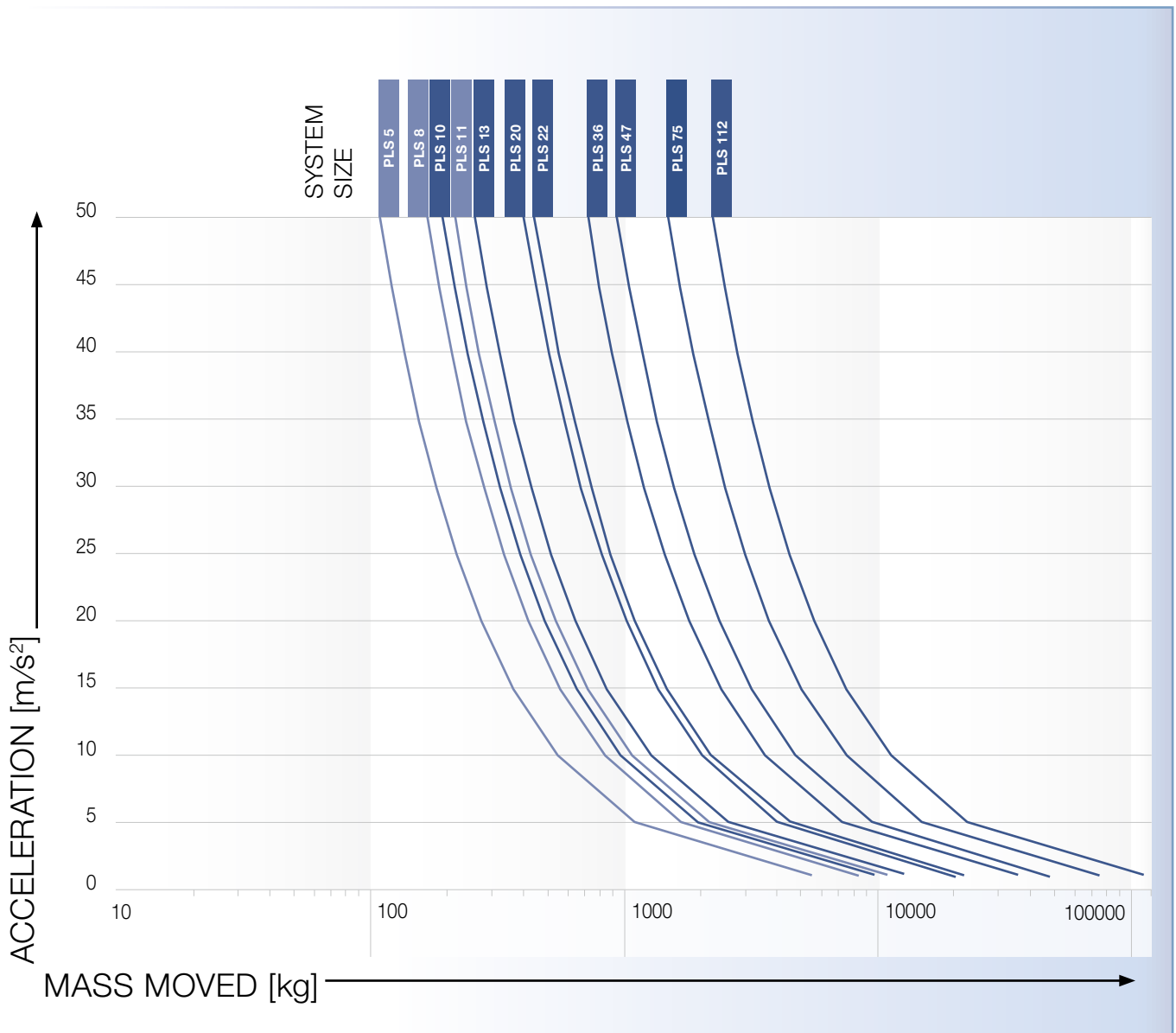

Premium Linear Systems

Premium Linear Systems overview

Our preferred linear systems are always comprised of the perfect combination of gearbox, pinion, rack and lubrication system. The systems are optimized to achieve the required feed force, feed speed, rigidity and degree of utilization of the individual components. Depending on your individual requirements, you have the option to further configure products via the ordering code. For a detailed dimensioning and configuration of the products we recommend to use cymex® 5.

System	Gearbox	Pinion	Rack
PLS 5	XP ⁺ 020R	RMW 200-444-20L1-033	ZST 200-333-1000-R1
PLS 8	XP ⁺ 030R	RMW 200-444-20L1-037	ZST 200-334-1000-R1
PLS 11	XP ⁺ 040R	RMW 300-444-20L1-055	ZST 300-333-1000-R1
PLS 10	RP ⁺ 030S	RMW 200-444-20L1-037	ZST 200-334-1000-R11
PLS 13	RP ⁺ 030S	RMW 300-444-20L1-055	ZST 300-334-1000-R11
PLS 20	RP ⁺ 040S	RMW 300-444-20L1-055	ZST 300-334-1000-R11
PLS 22	RP ⁺ 040S	RMW 400-444-20L1-073	ZST 400-334-1000-R11
PLS 36	RP ⁺ 050S	RMW 400-444-24L1-089	ZST 400-334-1000-R11
PLS 47	RP ⁺ 050S	RMW 500-444-23L1-106	ZST 500-334-1000-R11
PLS 75	RP ⁺ 060S	RMW 600-444-23L1-128	ZST 600-334-1000-R11
PLS 112	RP ⁺ 080S	RMW 800-444-21L1-156	ZST 800-334-960-R11

Assembly accessories can be found starting at page 128 and information on the lubrication system starting at page 116

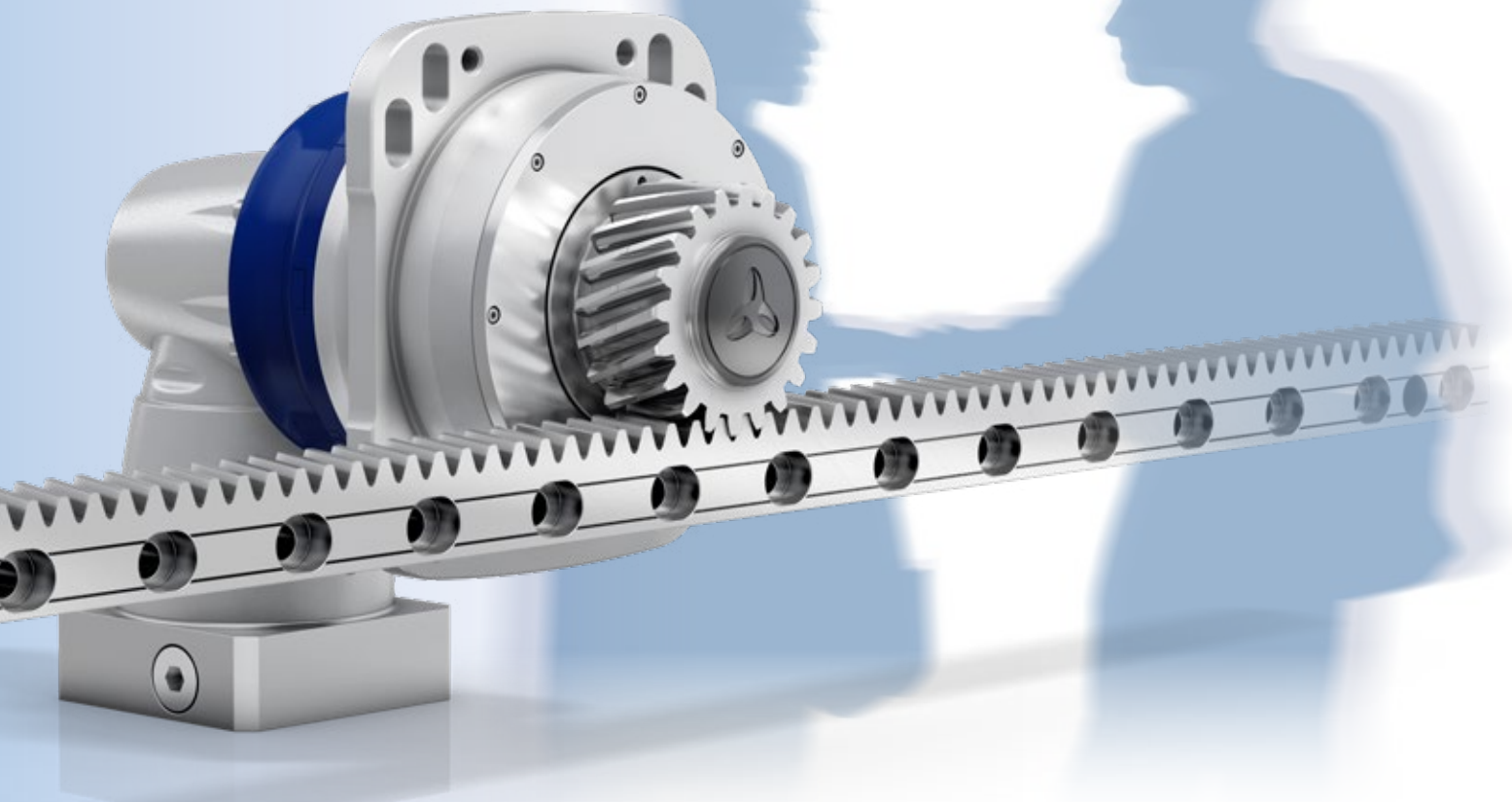

Ordering code

Gearbox*

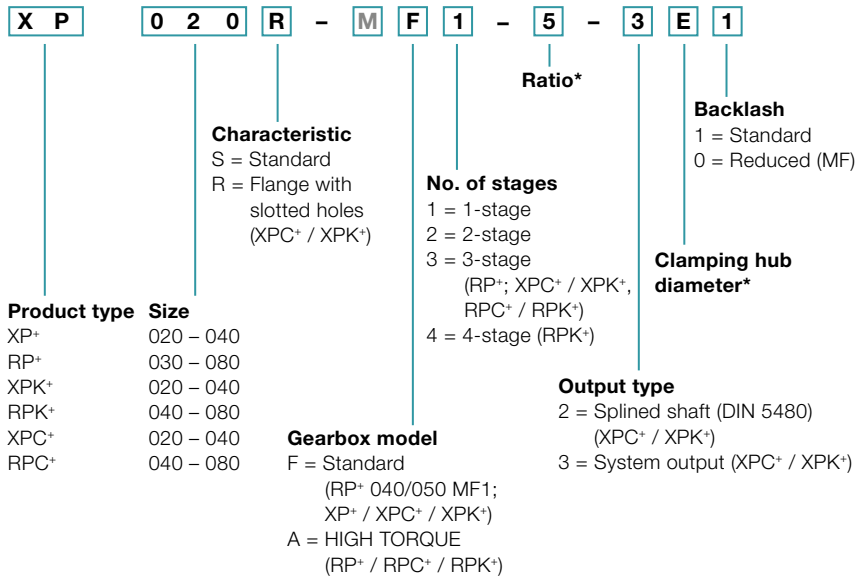

M Components with a gray font cannot be selected

* Further information about the gearboxes can be obtained from the respective catalogs, online at www.wittenstein-alpha.com or on request

** Full motor designation only required to determine gearbox mounting parts

Rack

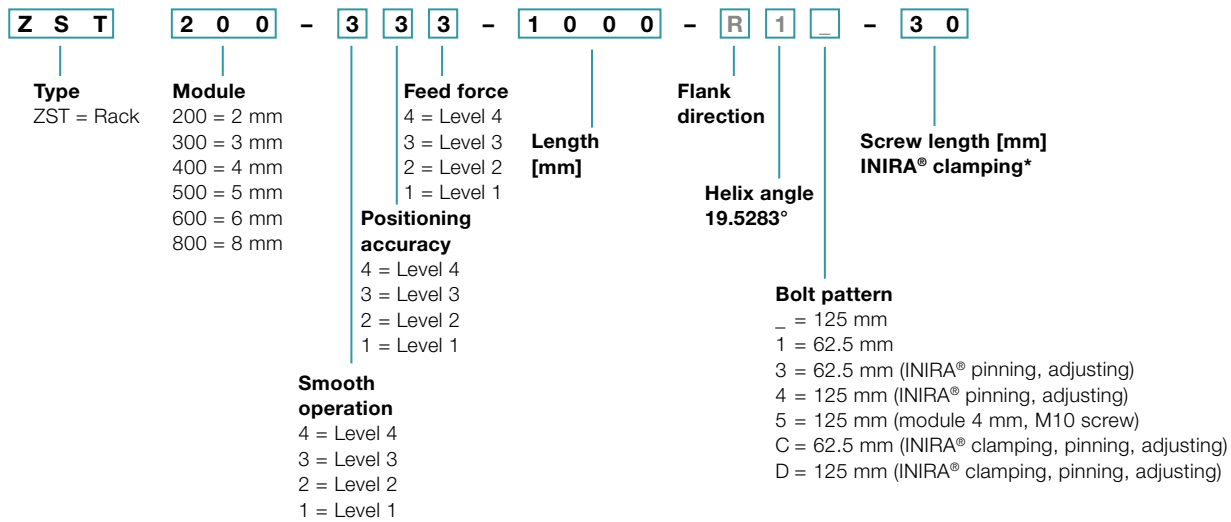

* Please refer to page 130 for an overview of available screw lengths

Pinion

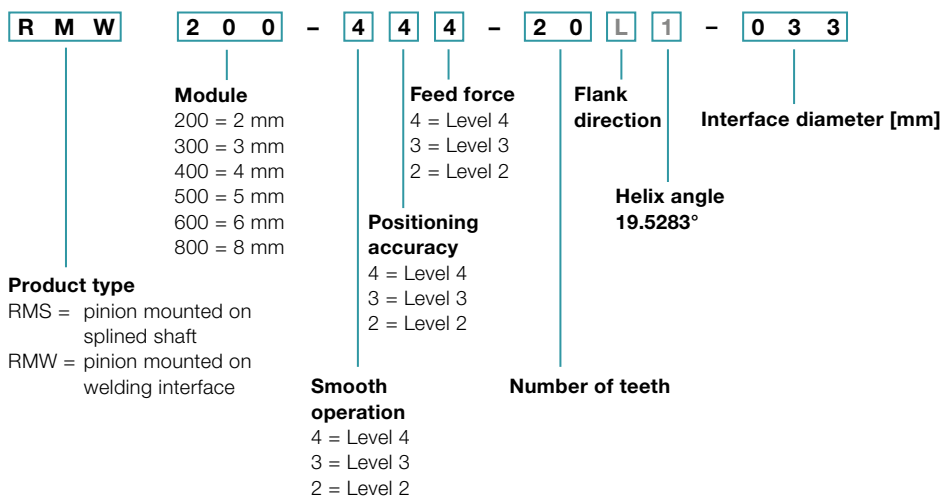

Premium Linear System PLS 5 with XP+

Planetary gearbox XP+ 020R MF with rack module 2 and pinion RMW module 2

System	Max. feed force ¹⁾ F_{zT}	5450 N	
	Max. feed speed ²⁾ v_{max}	333 m/min	71 m/min
Gearbox	No. of stages	1	2
	Ratios i	3 / 4 / 5 / 7 / 8 / 10	16 / 20 / 25 / 28 / 32 / 35 / 40 / 50 / 64 / 70 / 100
	Clamping hub diameter	14 / 24 mm	11 / 19 mm
	Designation	XP 020R-MF1-_-_-_-3_ _	XP 020R-MF2-_-_-_-3_ _
Pinion	Module m	2 mm	
	Number of teeth z	20	
	Pitch circle diameter d	42.441 mm	
	Profile correction factor x	0.4	
	Helix angle β	-19.5283° (left-handed)	
	Designation	RMW 200-444-20L1-033	
Rack	Module m	2 mm	
	Lengths L	1000 mm (500 mm)	
	Helix angle β	19.5283° (right-handed)	
	Designation	ZST 200-333-1000-R1; optionally with INIRA®	
Lubrication system ³⁾	Set consisting of lubrication pinion and axis for	Rack	LMT 200-PU -18L1-024-1
		Pinion	LMT 200-PU -18R1-024-1
	Lubricator	125 cm ³	LUC+125-0511-02
		400 cm ³	LUC+400-0511-02
	Lubricant	WITTENSTEIN alpha G11	

¹⁾ Maximum feed force depending on ratio and number of stages

²⁾ Calculation with lowest ratio and maximum input speed

³⁾ Impulse-controlled basic version with one output and 2 m hose. See page 116 for further information on the lubrication system. Application-specific dimensioning with cymex® – www.wittenstein-cymex.com

Alternative system solutions

Pinion			Axis distance	XP+ 020R	PHG 2R	XPC+ 020R	XPK+ 020R	Rack
Designation	d [mm]	x []	A [mm]	F_{zT} [N]	F_{zT} [N]	F_{zT} [N]	F_{zT} [N]	Designation
RMW 200-444-20L1-033	42.441	0.4	44.021	5450	5450	5450	5450	ZST 200-333-1000-R1; optionally with INIRA®
RMS 200-323-18L1-022	38.197	0.4	41.899	5400	5400	5400	5400	ZST 200-333-1000-R1; optionally with INIRA®
RMS 200-323-20L1-022	42.441	0.4	44.021	5300	5300	5300	5300	ZST 200-333-1000-R1; optionally with INIRA®
RMS 200-323-22L1-022	46.686	0.4	46.143	5100	5100	5100	5100	ZST 200-333-1000-R1; optionally with INIRA®

d = Pitch circle diameter

x = Addendum modification coefficient

A = Distance between pinion axle and rear surface of rack

F_{zT} = Maximum feed force depending on ratio and number of stages

Application-specific dimensioning with cymex® – www.wittenstein-cymex.com

1-stage

greater than 14 (C) up to 19⁴⁾ (E) clamping hub diameters

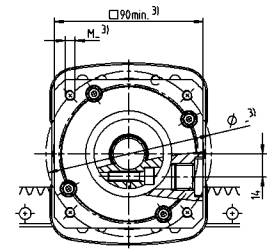
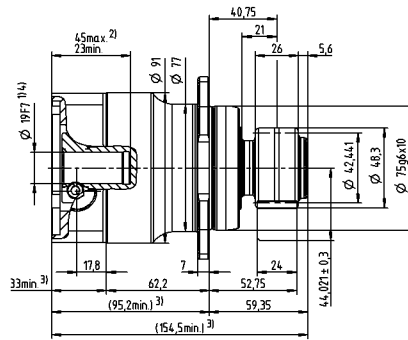
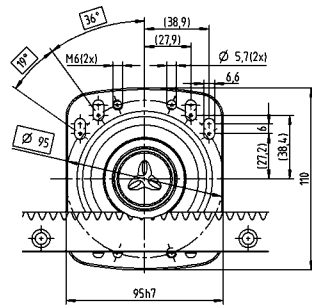

up to 24⁴⁾ (G) clamping hub diameters

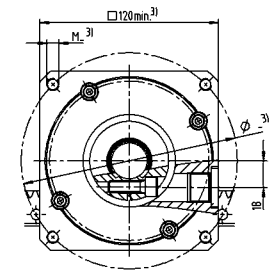
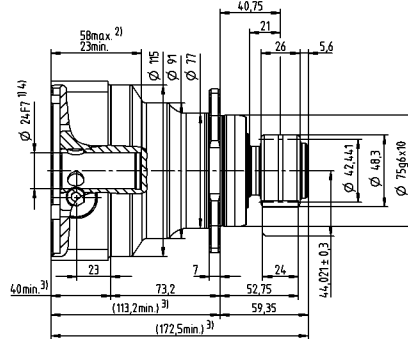
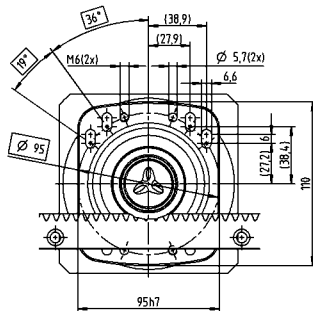

2-stage

greater than 11 (B) up to 14⁴⁾ (C) clamping hub diameters

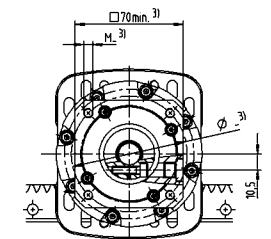
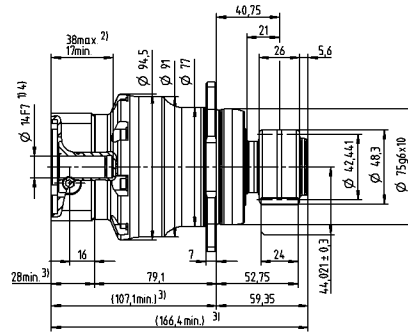
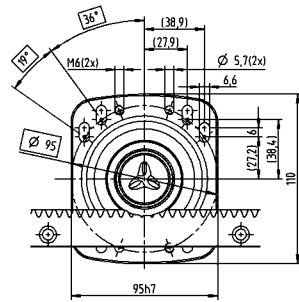

up to 19⁴⁾ (E) clamping hub diameters

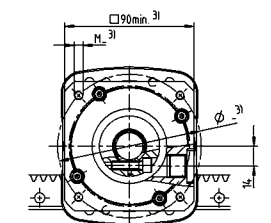
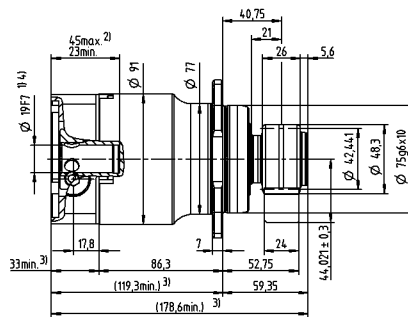
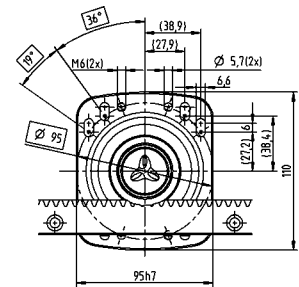

Motor shaft diameter [mm]

Non-tolerated dimensions are nominal dimensions
 Detailed rack dimensions starting on page 151
 1) Check motor shaft fit
 2) Min./Max. permissible motor shaft length. Longer motor shafts are possible, please contact alpha.
 3) The dimensions depend on the motor
 4) Smaller motor shaft diameter is compensated by a bushing with a minimum thickness of 1 mm

Premium Linear Systems

Premium Linear System PLS 8 with XP+

Planetary gearbox XP+ 030R MF with rack module 2 and pinion RMW module 2

System	Max. feed force ¹⁾ F_{2T}	8350 N	
	Max. feed speed ²⁾ v_{max}	244 m/min	54 m/min
Gearbox	No. of stages	1	2
	Ratios i	3 / 4 / 5 / 7 / 8 / 10	16 / 20 / 25 / 28 / 32 / 35 / 40 / 50 / 64 / 70 / 100
	Clamping hub diameter	19 / 24 / 28 / 38 mm	14 / 19 / 24 / 28 mm
	Designation	XP 030R-MF1-_-_-3-_-_-	XP 030R-MF2-_-_-3-_-_-
Pinion	Module m	2 mm	
	Number of teeth z	20	
	Pitch circle diameter d	42.441 mm	
	Profile correction factor x	0.4	
	Helix angle β	-19.5283° (left-handed)	
	Designation	RMW 200-444-20L1-037	
Rack	Module m	2 mm	
	Lengths L	1000 mm (500 mm)	
	Helix angle β	19.5283° (right-handed)	
	Designation	ZST 200-334-1000-R11; optionally with INIRA®	
Lubrication system ³⁾	Set consisting of lubrication pinion and axis for	Rack	LMT 200-PU -18L1-024-1
		Pinion	LMT 200-PU -18R1-024-1
	Lubricator	125 cm ³	LUC+125-0511-02
		400 cm ³	LUC+400-0511-02
	Lubricant	WITTENSTEIN alpha G11	

¹⁾ Maximum feed force depending on ratio and number of stages

²⁾ Calculation with lowest ratio and maximum input speed

³⁾ Impulse-controlled basic version with one output and 2 m hose. See page 116 for further information on the lubrication system. Application-specific dimensioning with cymex® – www.wittenstein-cymex.com

Alternative system solutions

Pinion			Axis distance	XP+ 030R	PHG 3R	XPC+ 030R	XPK+ 030R	Rack
Designation	d [mm]	x []	A [mm]	F_{2T} [N]	F_{2T} [N]	F_{2T} [N]	F_{2T} [N]	Designation
RMW 200-444-20L1-037	42.441	0.4	44.021	8350	8350	8350	8350	ZST 200-334-1000-R11; optionally with INIRA®
RMW 200-444-40L1-037	84.883	0.3	65.041	6080	6080	6080	6080	ZST 200-332-1000-R1; optionally with INIRA®
RMW 300-444-20L1-037	63.662	0.4	59.031	7200	7200	7200	7200	ZST 300-332-1000-R1; optionally with INIRA®
RMS 200-323-23L1-032	48.808	0.4	47.204	8350	8350	8350	8350	ZST 200-334-1000-R11; optionally with INIRA®
RMS 200-323-25L1-032	53.052	0.4	49.326	8350	8350	8350	8350	ZST 200-334-1000-R11; optionally with INIRA®
RMS 200-323-27L1-032	57.296	0.3	51.248	8350	8350	8350	8350	ZST 200-334-1000-R11; optionally with INIRA®

d = Pitch circle diameter

x = Addendum modification coefficient

A = Distance between pinion axle and rear surface of rack

F_{2T} = Maximum feed force depending on ratio and number of stages

Application-specific dimensioning with cymex® – www.wittenstein-cymex.com

1-stage

greater than 19 (E)
up to 24/28⁴⁾ (G/H)
clamping hub
diameters

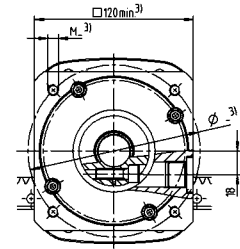
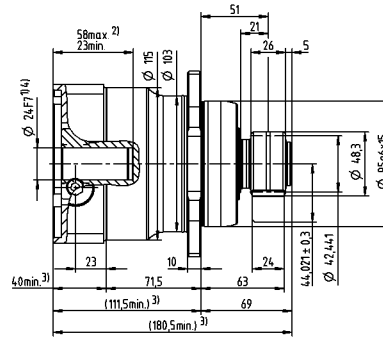
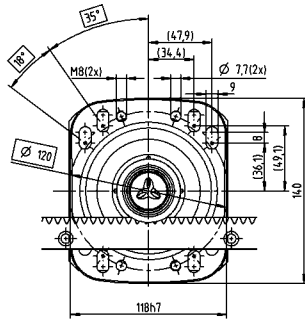

up to 38⁴⁾ (K)
clamping hub
diameters

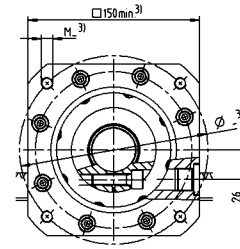
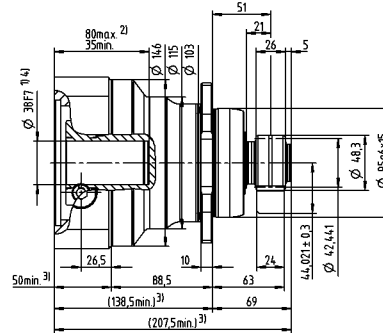
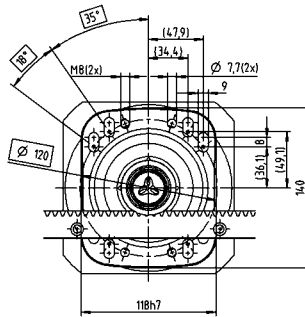

2-stage

greater than 14 (C)
up to 19⁴⁾ (E)
clamping hub
diameters

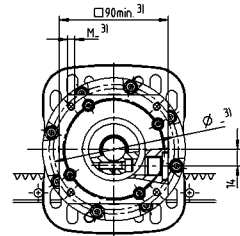
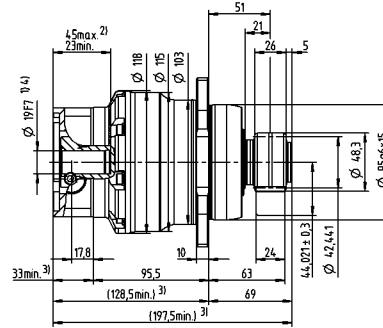
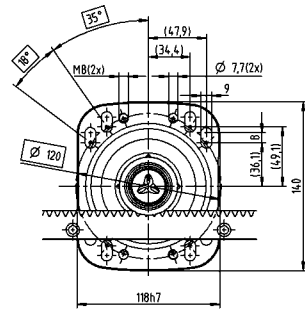

up to 28⁴⁾ (G)
clamping hub
diameters

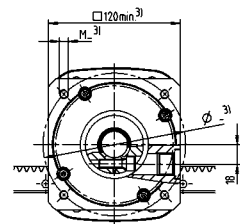
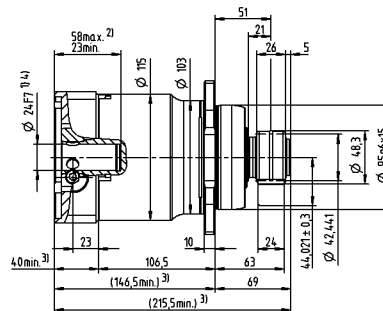
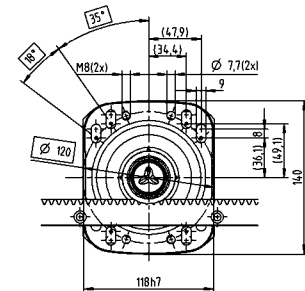

Non-tolerated dimensions are nominal dimensions
Detailed rack dimensions starting on page 151

¹⁾ Check motor shaft fit

²⁾ Min./Max. permissible motor shaft length. Longer motor shafts are possible, please contact alpha.

³⁾ The dimensions depend on the motor

⁴⁾ Smaller motor shaft diameter is compensated by a bushing with a minimum thickness of 1 mm

Motor shaft diameter [mm]

Premium Linear System PLS 11 with XP+

Planetary gearbox XP+ 040R MF with rack module 3 and pinion RMW module 3

System	Max. feed force ¹⁾ F_{2T}	10700 N	
	Max. feed speed ²⁾ v_{max}	333 m/min	75 m/min
Gearbox	No. of stages	1	2
	Ratios i	3 / 4 / 5 / 7 / 8 / 10	16 / 20 / 25 / 28 / 32 / 35 / 40 / 50 / 64 / 70 / 100
	Clamping hub diameter	24 / 32 / 38 / 48 mm	19 / 24 / 38 mm
	Designation	XP 040R-MF1-_-_-3_-_-	XP 040R-MF2-_-_-3_-_-
Pinion	Module m	3 mm	
	Number of teeth z	20	
	Pitch circle diameter d	63.662 mm	
	Profile correction factor x	0.4	
	Helix angle β	-19.5283° (left-handed)	
	Designation	RMW 300-444-20L1-055	
Rack	Module m	3 mm	
	Lengths L	1000 mm (500 mm)	
	Helix angle β	19.5283° (right-handed)	
	Designation	ZST 300-333-1000-R1; optionally with INIRA®	
Lubrication system ³⁾	Set consisting of lubrication pinion and axis for	Rack	LMT 300-PU -18L1-030-1
		Pinion	LMT 300-PU -18R1-030-1
	Lubricator	125 cm ³	LUC+125-0511-02
		400 cm ³	LUC+400-0511-02
	Lubricant	WITTENSTEIN alpha G11	

¹⁾ Maximum feed force depending on ratio and number of stages

²⁾ Calculation with lowest ratio and maximum input speed

³⁾ Impulse-controlled basic version with one output and 2 m hose. See page 116 for further information on the lubrication system.
Application-specific dimensioning with cymex® – www.wittenstein-cymex.com

Alternative system solutions

Pinion			Axis distance	XP+ 040R	XPK+ 040R	XPC+ 040R	Rack
Designation	d [mm]	x []	A [mm]	F_{2T} [N]	F_{2T} [N]	F_{2T} [N]	Designation
RMW 200-444-40L1-055	84.883	0	64.441	10700	10700	10700	ZST 200-334-1000-R11; optionally with INIRA®
RMW 300-444-20L1-055	63.662	0.4	59.031	10700	10700	10700	ZST 300-333-1000-R1; optionally with INIRA®
RMW 300-444-34L1-055	108.226	0	80.113	10700	10700	10700	ZST 300-333-1000-R1; optionally with INIRA®
RMS 300-323-20L1-040	63.662	0.4	59.031	10700	10700	10700	ZST 300-332-1000-R1; optionally with INIRA®
RMS 300-323-22L1-040	70.028	0.4	62.214	10700	10700	10700	ZST 300-332-1000-R1; optionally with INIRA®
RMS 300-323-24L1-040	76.394	0.4	65.397	10700	10700	10700	ZST 300-332-1000-R1; optionally with INIRA®

d = Pitch circle diameter

x = Addendum modification coefficient

A = Distance between pinion axle and rear surface of rack

F_{2T} = Maximum feed force depending on ratio and number of stages

Application-specific dimensioning with cymex® – www.wittenstein-cymex.com

1-stage

greater than 24 (G)
up to 32/38⁴⁾ (I/K)
clamping hub
diameters

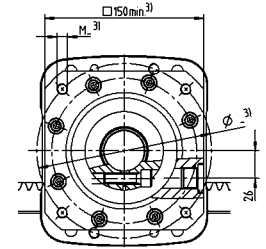
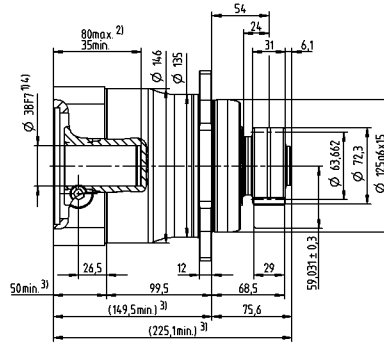
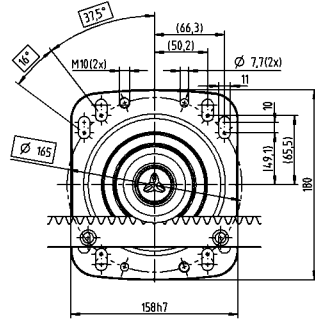

up to 48⁴⁾ (M)
clamping hub
diameters

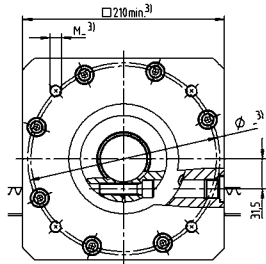
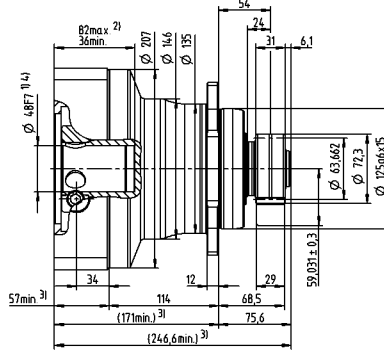
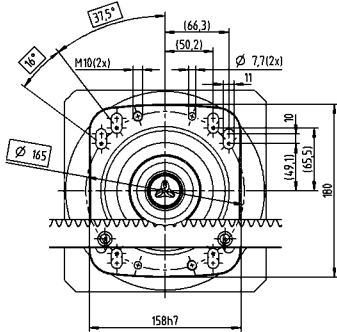

2-stage

greater than 19 (E)
up to 24⁴⁾ (G)
clamping hub
diameters

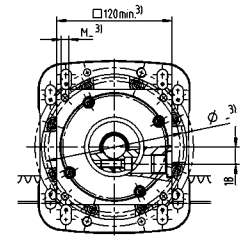
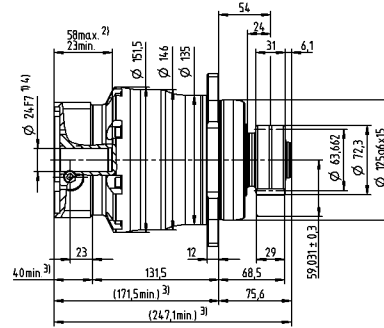
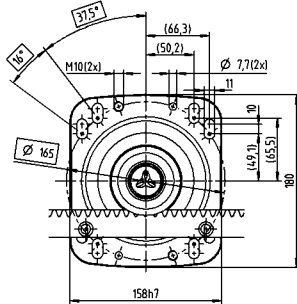

up to 38⁴⁾ (K)
clamping hub
diameters

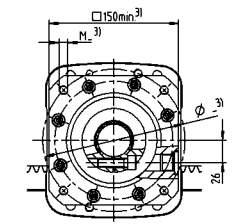
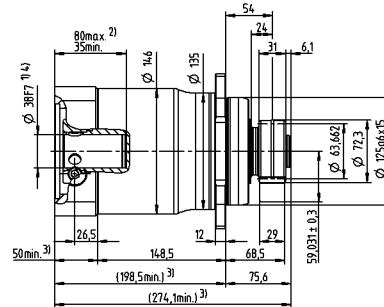
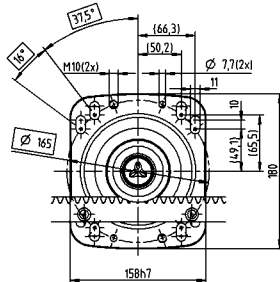

Motor shaft diameter [mm]

Non-tolerated dimensions are nominal dimensions
Detailed rack dimensions starting on page 151

¹⁾ Check motor shaft fit

²⁾ Min./Max. permissible motor shaft length. Longer motor shafts are possible, please contact alpha.

³⁾ The dimensions depend on the motor

⁴⁾ Smaller motor shaft diameter is compensated by a bushing with a minimum thickness of 1 mm

Premium Linear System PLS 10 with RP+

Planetary gearbox RP+ 030 MA with rack module 2 and pinion RMW module 2

System	Max. feed force ¹⁾ F_{zT}	9750 N	
	Max. feed speed ²⁾ v_{max}	133 m/min	
Gearbox	No. of stages ⁴⁾	1	
	Ratios i ⁵⁾	5.5	
	Clamping hub diameter	19 / 24 / 38 mm	
	Designation	RP 030S-MA1-_-_-_-3_ _	
Pinion	Module m	2 mm	
	Number of teeth z	20	
	Pitch circle diameter d	42.441 mm	
	Profile correction factor x	0.4	
	Helix angle β	-19.5283° (left-handed)	
	Designation	RMW 200-444-20L1-037	
Rack	Module m	2 mm	
	Lengths L	1000 mm (500 mm)	
	Helix angle β	19.5283° (right-handed)	
	Designation	ZST 200-334-1000-R11; optionally with INIRA®	
Lubrication system ³⁾	Set consisting of lubrication pinion and axis for	Rack	LMT 200-PU -18L1-024-1
		Pinion	LMT 200-PU -18L1-024-1
	Lubricator	125 cm ³	LUC+125-0511-02
		400 cm ³	LUC+400-0511-02
	Lubricant		WITTENSTEIN alpha G11

¹⁾ Maximum feed force depending on ratio and number of stages

²⁾ Calculation with lowest ratio and maximum input speed

³⁾ Impulse-controlled basic version with one output and 2 m hose. See page 116 for further information on the lubrication system.

Application-specific dimensioning with cymex® – www.wittenstein-cymex.com

⁴⁾ Also available with multiple stages.

⁵⁾ Additional 1-stage ratios 4 / 5 / 7 / 10 available for RP+ 030 MF

Alternative system solutions

Pinion			Axis distance	RP+ 030S	Rack
Designation	d [mm]	x []	A [mm]	F_{zT} [N]	Designation
RMW 200-444-40L1-055	84.883	0	64.441	11300	ZST 200-334-1000-R11; optionally with INIRA®
RMW 300-444-20L1-055	63.662	0.4	59.031	12900	ZST 300-333-1000-R1; optionally with INIRA®
RMW 300-444-34L1-055	108.226	0	80.113	9800	ZST 300-332-1000-R1; optionally with INIRA®
RMW 400-444-20L1-055	84.882	0.2	78.241	12500	ZST 400-332-1000-R1; optionally with INIRA®

d = Pitch circle diameter

x = Addendum modification coefficient

A = Distance between pinion axle and rear surface of rack

F_{zT} = Maximum feed force depending on ratio and number of stages

RPM+ available in customized version

Application-specific dimensioning with cymex® – www.wittenstein-cymex.com

1-stage

up to 19⁴⁾ (E)
clamping hub
diameters

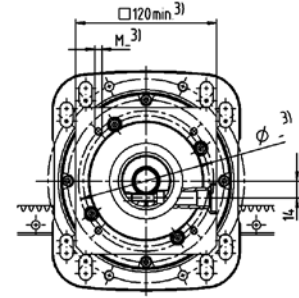
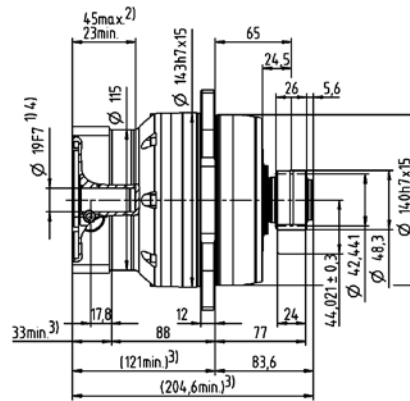
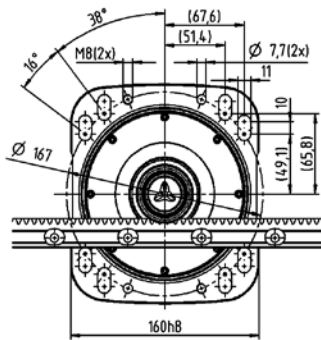

up to 24⁴⁾ (G)
clamping hub
diameters

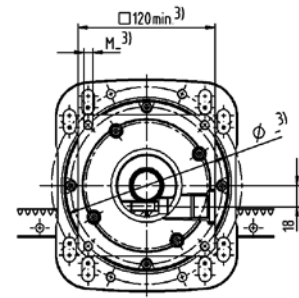
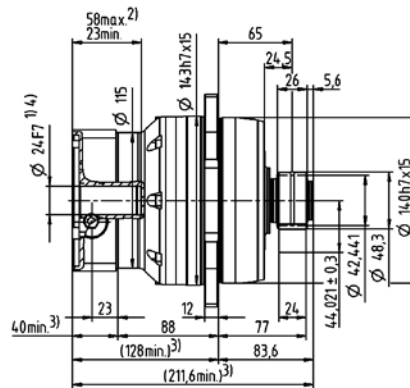
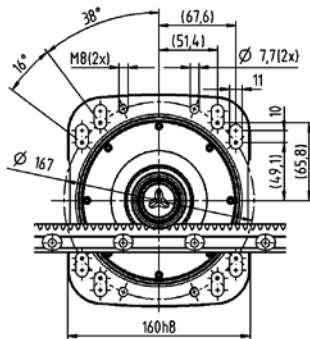

up to 38⁴⁾ (K)
clamping hub
diameters

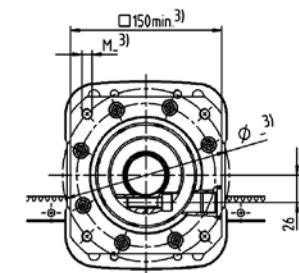
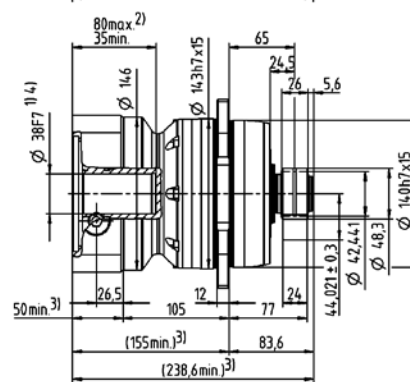
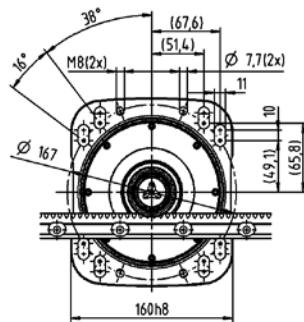

Motor shaft diameter [mm]

Non-tolerated dimensions are nominal dimensions
Detailed rack dimensions starting on page 151

¹⁾ Check motor shaft fit

²⁾ Min./Max. permissible motor shaft length. Longer motor shafts are possible, please contact alpha.

³⁾ The dimensions depend on the motor

⁴⁾ Smaller motor shaft diameter is compensated by a bushing with a minimum thickness of 1 mm

Premium Linear System PLS 13 with RP+

Planetary gearbox RP+ 030 MA with rack module 3 and pinion RMW module 3

System	Max. feed force ¹⁾ F_{zT}		12900 N
	Max. feed speed ²⁾ v_{max}		200 m/min
Gearbox	No. of stages ⁴⁾		1
	Ratios i ⁵⁾		5.5
	Clamping hub diameter		19 / 24 / 38 mm
	Designation		RP 030S-MA1-__-3__
Pinion	Module m		3 mm
	Number of teeth z		20
	Pitch circle diameter d		63.662 mm
	Profile correction factor x		0.4
	Helix angle β		-19.5283° (left-handed)
	Designation		RMW 300-444-20L1-055
Rack	Module m		3 mm
	Lengths L		1000 mm (500 mm)
	Helix angle β		19.5283° (right-handed)
	Designation		ZST 300-334-1000-R11; optionally with INIRA®
Lubrication system ³⁾	Set consisting of lubrication pinion and axis for	Rack	LMT 300-PU -18L1-030-1
		Pinion	LMT 300-PU -18R1-030-1
	Lubricator	125 cm ³	LUC+125-0511-02
		400 cm ³	LUC+400-0511-02
	Lubricant		WITTENSTEIN alpha G11

¹⁾ Maximum feed force depending on ratio and number of stages

²⁾ Calculation with lowest ratio and maximum input speed

³⁾ Impulse-controlled basic version with one output and 2 m hose. See page 116 for further information on the lubrication system.

Application-specific dimensioning with cymex® – www.wittenstein-cymex.com

⁴⁾ Also available with multiple stages.

⁵⁾ Additional 1-stage ratios 4 / 5 / 7 / 10 available for RP+ 030 MF

Alternative system solutions

Pinion			Axis distance	RP+ 030S	Rack
Designation	d [mm]	x []	A [mm]	F_{zT} [N]	Designation
RMW 200-444-20L1-037	42.441	0.4	44.021	9750	ZST 200-334-1000-R11; optionally with INIRA®
RMW 200-444-40L1-055	84.883	0	64.441	11300	ZST 200-334-1000-R11; optionally with INIRA®
RMW 300-444-34L1-055	108.226	0	80.113	9800	ZST 300-332-1000-R1; optionally with INIRA®
RMW 400-444-20L1-055	84.882	0.2	78.241	12500	ZST 400-332-1000-R1; optionally with INIRA®

d = Pitch circle diameter

x = Addendum modification coefficient

A = Distance between pinion axle and rear surface of rack

F_{zT} = Maximum feed force depending on ratio and number of stages

RPM+ available in customized version

Application-specific dimensioning with cymex® – www.wittenstein-cymex.com

1-stage

up to 19⁴⁾ (E)
clamping hub
diameters

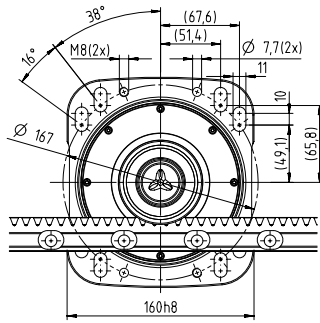

up to 24⁴⁾ (G)
clamping hub
diameters

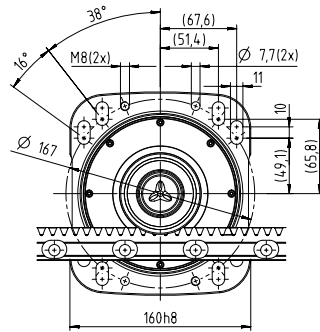

up to 38⁴⁾ (K)
clamping hub
diameters

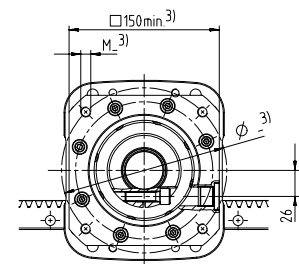
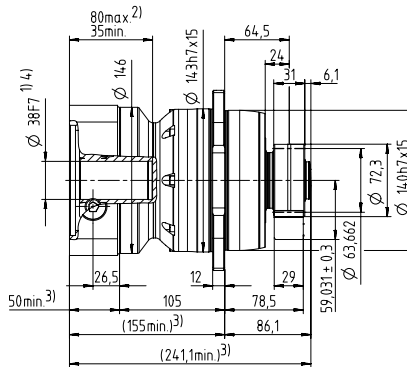
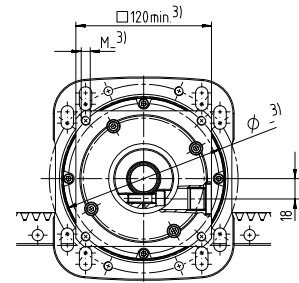
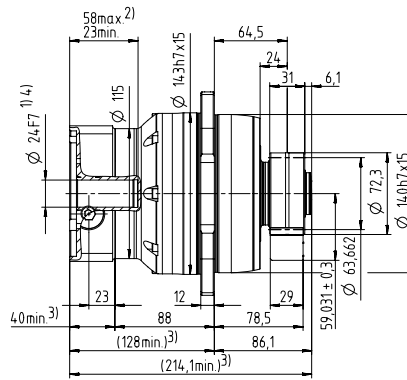
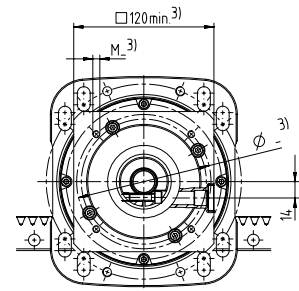
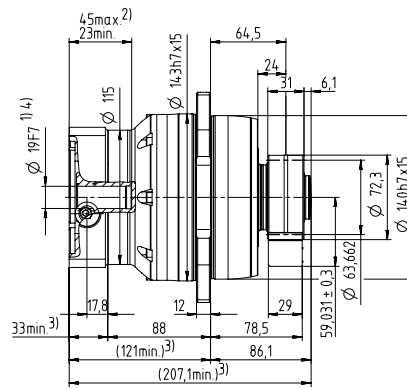
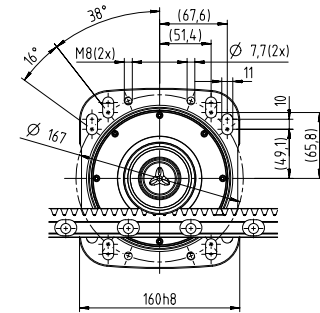

Non-tolerated dimensions are nominal dimensions
Detailed rack dimensions starting on page 151

¹⁾ Check motor shaft fit

²⁾ Min./Max. permissible motor shaft length. Longer motor shafts are possible, please contact alpha.

³⁾ The dimensions depend on the motor

⁴⁾ Smaller motor shaft diameter is compensated by a bushing with a minimum thickness of 1 mm

Motor shaft diameter [mm]

Premium Linear System PLS 20 with RP+

Planetary gearbox RP+ 040 MF with rack module 3 and pinion RMW module 3

System	Max. feed force ¹⁾ F_{zT}		20300 N
	Max. feed speed ²⁾ v_{max}		250 m/min
Gearbox	No. of stages		1
	Ratios i		4 / 5 / 7 / 10
	Clamping hub diameter		24 / 38 / 48 mm
	Designation		RP 040S-MF1-_-_-3_-_-
Pinion	Module m		3 mm
	Number of teeth z		20
	Pitch circle diameter d		63.662 mm
	Profile correction factor x		0.4
	Helix angle β		-19.5283° (left-handed)
	Designation		RMW 300-444-20L1-055
Rack	Module m		3 mm
	Lengths L		1000 mm (500 mm)
	Helix angle β		19.5283° (right-handed)
	Designation		ZST 300-334-1000-R11; optionally with INIRA®
Lubrication system ³⁾	Set consisting of lubrication pinion and axis for	Rack	LMT 300-PU -18L1-030-1
		Pinion	LMT 300-PU -18R1-030-1
	Lubricator	125 cm ³	LUC+125-0511-02
		400 cm ³	LUC+400-0511-02
	Lubricant		WITTENSTEIN alpha G11

¹⁾ Maximum feed force depending on ratio and number of stages

²⁾ Calculation with lowest ratio and maximum input speed

³⁾ Impulse-controlled basic version with one output and 2 m hose. See page 116 for further information on the lubrication system.
Application-specific dimensioning with cymex® – www.wittenstein-cymex.com

Alternative system solutions

Pinion			Axis distance	RP+ 040S	RPM+ 040S	RPC+ 040S	RPK+ 040S	Rack
Designation	d [mm]	x []	A [mm]	F_{zT} [N]	F_{zT} [N]	F_{zT} [N]	F_{zT} [N]	Designation
RMW 300-444-20L1-055	63.662	0.4	59.031	20300	20300	20300	20300	ZST 300-334-1000-R11; optionally with INIRA®
RMW 300-444-34L1-073	108.226	0	80.113	12900	12900	12900	12900	ZST 300-334-1000-R11; optionally with INIRA®
RMW 400-444-20L1-073	84.882	0.2	78.241	16400	16400	16400	16400	ZST 400-333-1000-R1; optionally with INIRA®

d = Pitch circle diameter

x = Addendum modification coefficient

A = Distance between pinion axle and rear surface of rack

F_{zT} = Maximum feed force depending on ratio and number of stages

RPM+ available in customized version

Application-specific dimensioning with cymex® – www.wittenstein-cymex.com

1-stage

up to 24⁴⁾ (G)
clamping hub
diameters

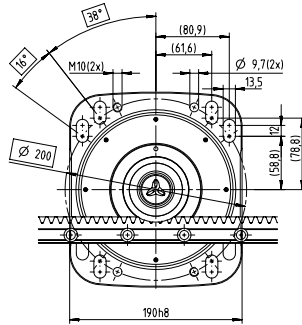

up to 38⁴⁾ (K)
clamping hub
diameters

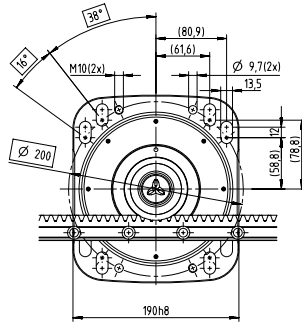

up to 48⁴⁾ (M)
clamping hub
diameters

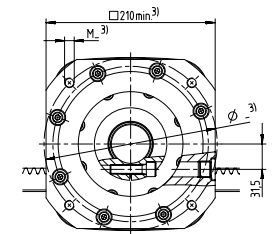
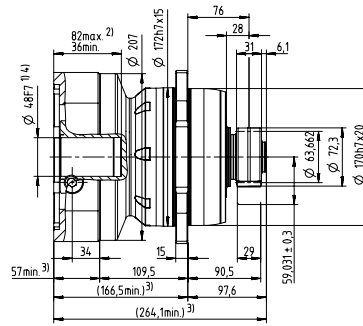
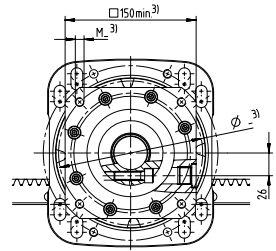
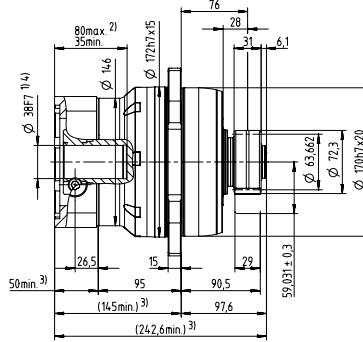
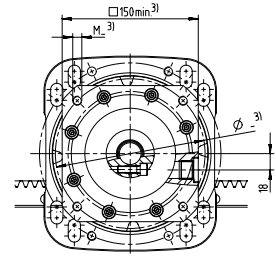
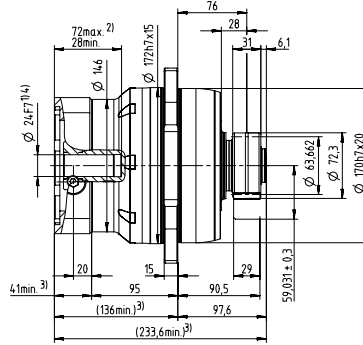
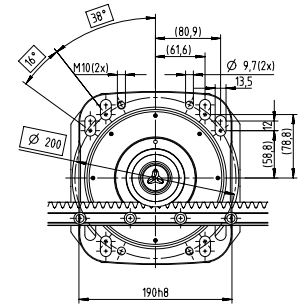

Motor shaft diameter [mm]

Non-tolerated dimensions are nominal dimensions
Detailed rack dimensions starting on page 151

¹⁾ Check motor shaft fit

²⁾ Min./Max. permissible motor shaft length. Longer motor shafts are possible, please contact alpha.

³⁾ The dimensions depend on the motor

⁴⁾ Smaller motor shaft diameter is compensated by a bushing with a minimum thickness of 1 mm

Premium Linear System PLS 22 with RP+

Planetary gearbox RP+ 040 MA with rack module 4 and pinion RMW module 4

System	Max. feed force ¹⁾ F_{zT}		22300 N	
	Max. feed speed ²⁾ v_{max}		104 m/min	25 m/min
Gearbox	No. of stages ³⁾		2	3
	Ratios i		16 / 22 / 27.5 / 38.5 / 55	66 / 88 / 110 / 154 / 220
	Clamping hub diameter		24 / 38 mm	24 mm
	Designation		RP 040S-MA2-_-_-_-3_-_-	RP 040S-MA3-_-_-_-3_-_-
Pinion	Module m		4 mm	
	Number of teeth z		20	
	Pitch circle diameter d		84.883 mm	
	Profile correction factor x		0.2	
	Helix angle β		-19.5283° (left-handed)	
	Designation		RMW 400-444-20L1-073	
Rack	Module m		4 mm	
	Lengths L		1000 mm (493 mm)	
	Helix angle β		19.5283° (right-handed)	
	Designation		ZST 400-334-1000-R11; optionally with INIRA®	
Lubrication system ⁴⁾	Set consisting of lubrication pinion and axis for	Rack	LMT 400-PU -18L1-040-1	
		Pinion	LMT 400-PU -18R1-040-1	
	Lubricator	125 cm ³	LUC+125-0511-02	
		400 cm ³	LUC+400-0511-02	
	Lubricant		WITTENSTEIN alpha G11	

¹⁾ Maximum feed force depending on ratio and number of stages

²⁾ Calculation with lowest ratio and maximum input speed

³⁾ Single-stage also available

⁴⁾ Impulse-controlled basic version with one output and 2 m hose. See page 116 for further information on the lubrication system.

Application-specific dimensioning with cymex® – www.wittenstein-cymex.com

Alternative system solutions

Pinion			Axis distance	RP+ 040S	RPM+ 040S	RPC+ 040S	RPK+ 040S	Rack
Designation	d [mm]	x []	A [mm]	F_{zT} [N]	F_{zT} [N]	F_{zT} [N]	F_{zT} [N]	Designation
RMW 300-444-20L1-055	63.662	0.4	59.031	20300	20300	20300	20300	ZST 300-334-1000-R11; optionally with INIRA®
RMW 300-444-34L1-073	108.226	0	80.113	20300	20300	20300	20300	ZST 300-334-1000-R11; optionally with INIRA®
RMW 400-444-20L1-073	84.882	0.2	78.241	22300	22300	22300	22300	ZST 400-333-1000-R15; optionally with INIRA®
RMW 400-444-24L1-073	101.859	0	85.930	20300	20300	20300	20300	ZST 400-332-1000-R15; optionally with INIRA®

d = Pitch circle diameter

x = Addendum modification coefficient

A = Distance between pinion axle and rear surface of rack

F_{zT} = Maximum feed force depending on ratio and number of stages

RPM+ available in customized version

Application-specific dimensioning with cymex® – www.wittenstein-cymex.com

2-stage

up to 24⁴⁾ (G)
clamping hub
diameters

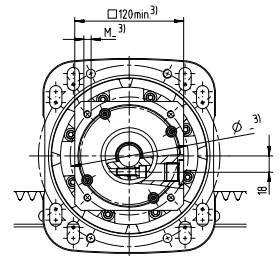
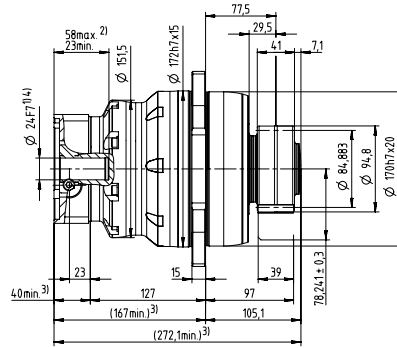
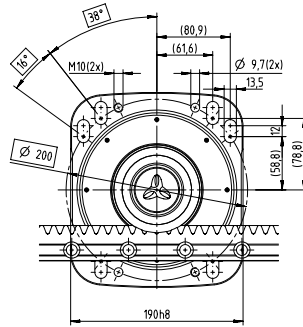

up to 38⁴⁾ (K)
clamping hub
diameters

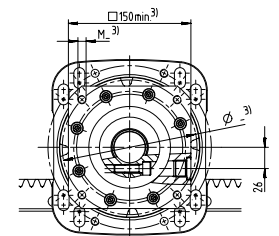
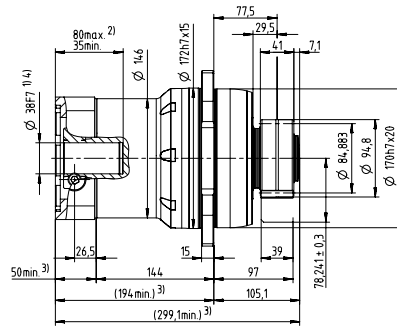
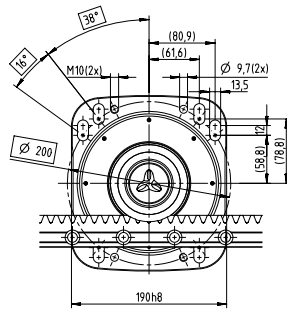

3-stage

up to 24⁴⁾ (G)
clamping hub
diameters

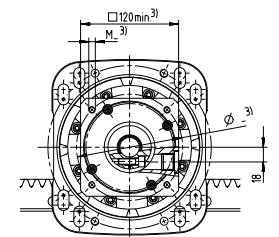
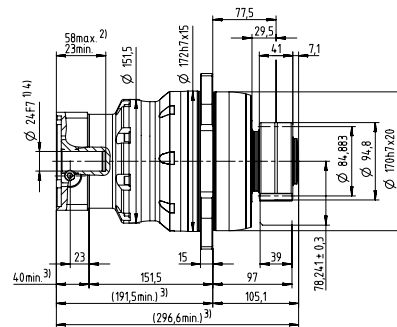
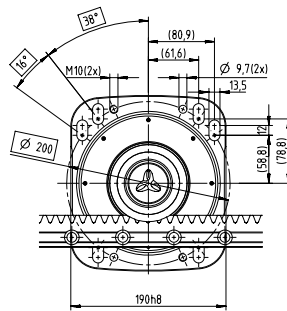

Motor shaft diameter [mm]

Premium Linear
Systems

Non-tolerated dimensions are nominal dimensions
Detailed rack dimensions starting on page 151

¹⁾ Check motor shaft fit

²⁾ Min./Max. permissible motor shaft length. Longer motor shafts are possible, please contact alpha.

³⁾ The dimensions depend on the motor

⁴⁾ Smaller motor shaft diameter is compensated by a bushing with a minimum thickness of 1 mm

Premium Linear System PLS 36 with RP+

Planetary gearbox RP+ 050 MA with rack module 4 and pinion RMW module 4

System	Max. feed force ¹⁾ F_{zT}		36100 N	
	Max. feed speed ²⁾ v_{max}		112 m/min	27 m/min
Gearbox	No. of stages ³⁾		2	3
	Ratios i		16 / 22 / 27.5 / 38.5 / 55	66 / 88 / 110 / 154 / 220
	Clamping hub diameter		38 / 48 mm	38 mm
	Designation		RP 050S-MA2-_-_-_-3_ _	RP 050S-MA3-_-_-_-3_ _
Pinion	Module m		4 mm	
	Number of teeth z		24	
	Pitch circle diameter d		101.859 mm	
	Profile correction factor x		0	
	Helix angle β		-19.5283° (left-handed)	
	Designation		RMW 400-444-24L1-089	
Rack	Module m		4 mm	
	Lengths L		1000 mm (493 mm)	
	Helix angle β		19.5283° (right-handed)	
	Designation		ZST 400-334-1000-R11; optionally with INIRA®	
Lubrication system ⁴⁾	Set consisting of lubrication pinion and axis for	Rack	LMT 400-PU -18L1-040-1	
		Pinion	LMT 400-PU -18R1-040-1	
	Lubricator	125 cm ³	LUC+125-0511-02	
		400 cm ³	LUC+400-0511-02	
	Lubricant		WITTENSTEIN alpha G11	

¹⁾ Maximum feed force depending on ratio and number of stages

²⁾ Calculation with lowest ratio and maximum input speed

³⁾ Single-stage also available

⁴⁾ Impulse-controlled basic version with one output and 2 m hose. See page 116 for further information on the lubrication system.

Application-specific dimensioning with cymex® – www.wittenstein-cymex.com

Alternative system solutions

Pinion			Axis distance	RP+ 050S	RPM+ 050S	RPC+ 050S	RPK+ 050S	Rack
Designation	d [mm]	x []	A [mm]	F_{zT} [N]	F_{zT} [N]	F_{zT} [N]	F_{zT} [N]	Designation
RMW 400-444-24L1-089	101.859	0	85.930	36100	36100	36100	36100	ZST 400-334-1000-R11; optionally with INIRA®
RMW 400-444-30L1-089	127.324	0	98.662	31400	31400	31400	31400	ZST 400-334-1000-R11; optionally with INIRA®
RMW 500-444-19L1-089	100.798	0.4	86.399	36500	36500	36500	36500	ZST 500-333-1000-R1; optionally with INIRA®
RMW 500-444-23L1-106	122.019	0	95.009	47200	47200	47200	47200	ZST 500-334-1000-R11; optionally with INIRA®
RMW 500-444-30L1-106	159.155	0	113.578	39200	39200	39200	39200	ZST 500-334-1000-R11; optionally with INIRA®
RMW 600-444-19L1-106	120.958	0.4	105.879	47200	47200	47200	47200	ZST 600-334-1000-R11; optionally with INIRA®
RMW 600-444-23L1-106	146.423	0	116.211	41500	41500	41500	41500	ZST 600-332-1000-R1; optionally with INIRA®

d = Pitch circle diameter

x = Addendum modification coefficient

A = Distance between pinion axle and rear surface of rack

F_{zT} = Maximum feed force depending on ratio and number of stages

RPM+ available in customized version

Application-specific dimensioning with cymex® – www.wittenstein-cymex.com

2-stage

up to 38⁴⁾ (K)
clamping hub
diameters

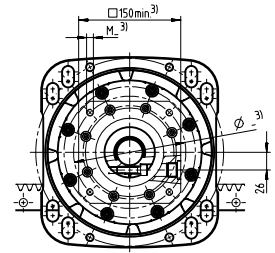
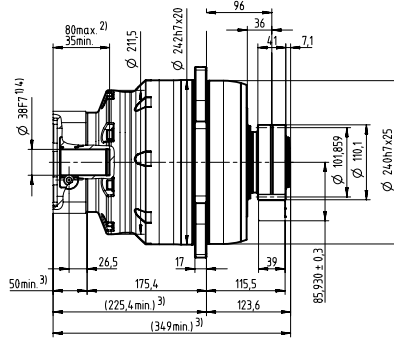
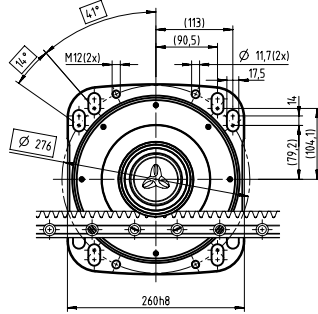

up to 48⁴⁾ (M)
clamping hub
diameters

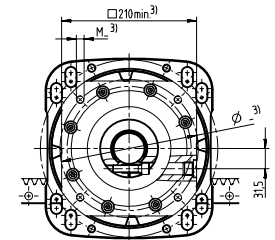
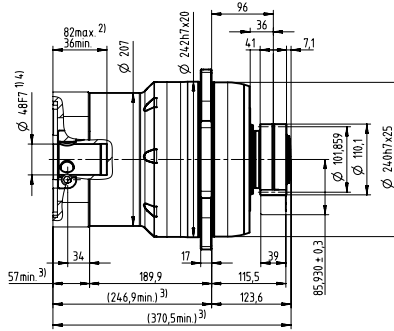
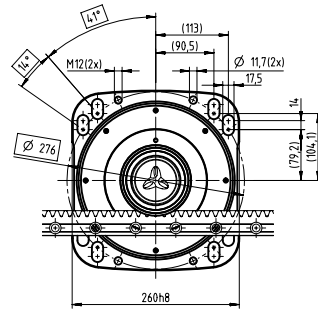

3-stage

up to 38⁴⁾ (K)
clamping hub
diameters

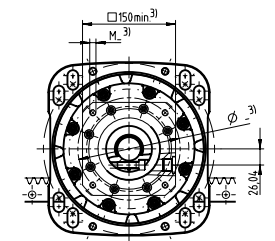
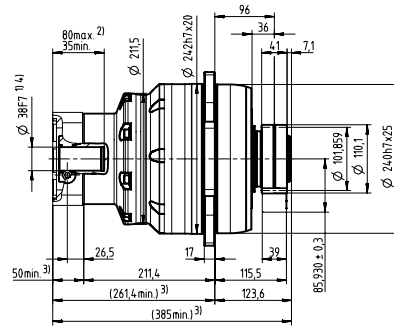
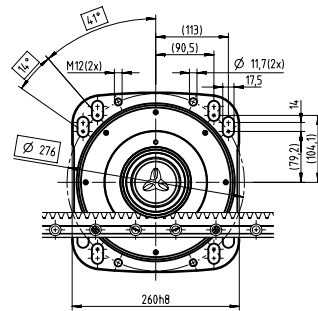

Motor shaft diameter [mm]

Non-tolerated dimensions are nominal dimensions
Detailed rack dimensions starting on page 151

¹⁾ Check motor shaft fit

²⁾ Min./Max. permissible motor shaft length. Longer motor shafts are possible, please contact alpha.

³⁾ The dimensions depend on the motor

⁴⁾ Smaller motor shaft diameter is compensated by a bushing with a minimum thickness of 1 mm

Premium Linear System PLS 47 with RP+

Planetary gearbox RP+ 050 MA with rack module 5 and pinion RMW module 5

System	Max. feed force ¹⁾ F_{zT}		47000 N	
	Max. feed speed ²⁾ v_{max}		135 m/min	33 m/min
Gearbox	No. of stages ³⁾		2	3
	Ratios i		22 / 27.5 / 38.5 / 55	66 / 88 / 110 / 154 / 220
	Clamping hub diameter		38 / 48 mm	38 mm
	Designation		RP 050S-MA2-_-_-_-3_ _	RP 050S-MA3-_-_-_-3_ _
Pinion	Module m		5 mm	
	Number of teeth z		23	
	Pitch circle diameter d		122.019 mm	
	Profile correction factor x		0	
	Helix angle β		-19.5283° (left-handed)	
	Designation		RMW 500-444-23L1-106	
Rack	Module m		5 mm	
	Lengths L		1000 mm (500 mm)	
	Helix angle β		19.5283° (right-handed)	
	Designation		ZST 500-334-1000-R11; optionally with INIRA®	
Lubrication system ⁴⁾	Set consisting of lubrication pinion and axis for	Rack	LMT 500-PU -17L1-050-1	
		Pinion	LMT 500-PU -17R1-050-1	
	Lubricator	125 cm ³	LUC+125-0511-02	
		400 cm ³	LUC+400-0511-02	
	Lubricant		WITTENSTEIN alpha G11	

¹⁾ Maximum feed force depending on ratio and number of stages

²⁾ Calculation with lowest ratio and maximum input speed

³⁾ Single-stage also available

⁴⁾ Impulse-controlled basic version with one output and 2 m hose. See page 116 for further information on the lubrication system.

Application-specific dimensioning with cymex® – www.wittenstein-cymex.com

Alternative system solutions

Pinion			Axis distance	RP+ 050S	RPM+ 050S	RPC+ 050S	RPK+ 050S	Rack
Designation	d [mm]	x []	A [mm]	F_{zT} [N]	F_{zT} [N]	F_{zT} [N]	F_{zT} [N]	Designation
RMW 400-444-24L1-089	101.859	0	85.930	36100	36100	36100	36100	ZST 400-334-1000-R11; optionally with INIRA®
RMW 400-444-30L1-089	127.324	0	98.662	31400	31400	31400	31400	ZST 400-334-1000-R11; optionally with INIRA®
RMW 500-444-19L1-089	100.798	0.4	86.399	36500	36500	36500	36500	ZST 500-333-1000-R1; optionally with INIRA®
RMW 500-444-23L1-106	122.019	0	95.009	47200	47200	47200	47200	ZST 500-334-1000-R11; optionally with INIRA®
RMW 500-444-30L1-106	159.155	0	113.578	39200	39200	39200	39200	ZST 500-334-1000-R11; optionally with INIRA®
RMW 600-444-19L1-106	120.958	0.4	105.879	47200	47200	47200	47200	ZST 600-333-1000-R1; optionally with INIRA®
RMW 600-444-23L1-106	146.423	0	116.211	41500	41500	41500	41500	ZST 600-332-1000-R1; optionally with INIRA®

d = Pitch circle diameter

x = Addendum modification coefficient

A = Distance between pinion axle and rear surface of rack

F_{zT} = Maximum feed force depending on ratio and number of stages

RPM+ available in customized version

Application-specific dimensioning with cymex® – www.wittenstein-cymex.com

2-stage

up to 38⁴⁾ (K)
clamping hub
diameters

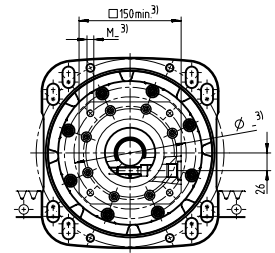
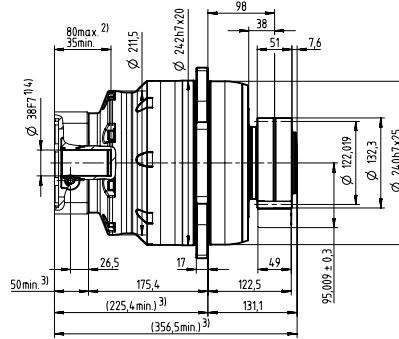
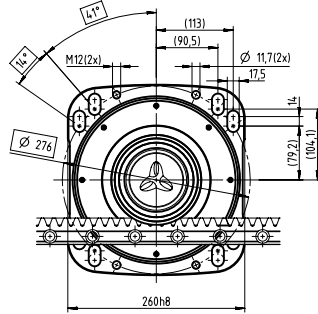

up to 48⁴⁾ (M)
clamping hub
diameters

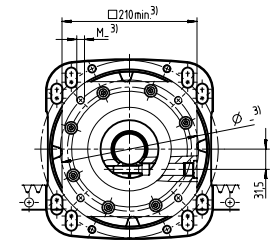
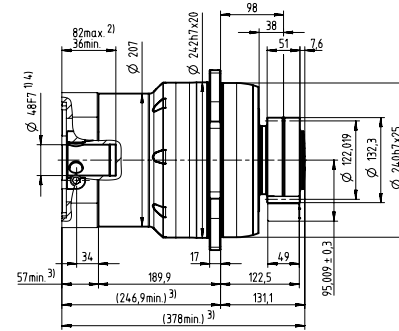
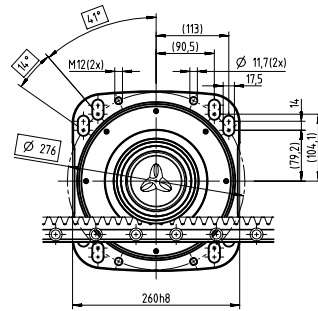

3-stage

up to 38⁴⁾ (K)
clamping hub
diameters

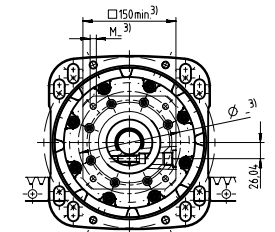
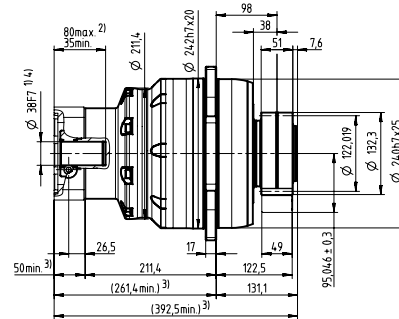
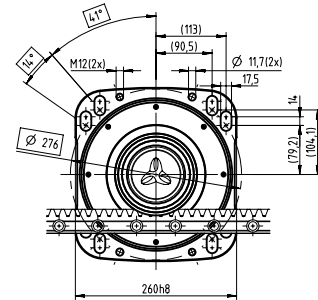

Motor shaft diameter [mm]

Non-tolerated dimensions are nominal dimensions
Detailed rack dimensions starting on page 151

- ¹⁾ Check motor shaft fit
- ²⁾ Min./Max. permissible motor shaft length. Longer motor shafts are possible, please contact alpha.
- ³⁾ The dimensions depend on the motor
- ⁴⁾ Smaller motor shaft diameter is compensated by a bushing with a minimum thickness of 1 mm

Premium Linear System PLS 75 with RP+

Planetary gearbox RP+ 060 MA with rack module 6 and pinion RMW module 6

System	Max. feed force ¹⁾ F_{zT}		75000 N	
	Max. feed speed ²⁾ v_{max}		91 m/min	30 m/min
Gearbox	No. of stages ³⁾		2	3
	Ratios i		22 / 27.5 / 38.5 / 55	66 / 88 / 110 / 154 / 220
	Clamping hub diameter		48 mm	38 mm
	Designation		RP 060S-MA2-_-_-_-3_ _	RP 060S-MA3-_-_-_-3_ _
Pinion	Module m		6 mm	
	Number of teeth z		23	
	Pitch circle diameter d		146.423 mm	
	Profile correction factor x		0	
	Helix angle β		-19.5283° (left-handed)	
	Designation		RMW 600-444-23L1-128	
Rack	Module m		6 mm	
	Lengths L		1000 mm (500 mm)	
	Helix angle β		19.5283° (right-handed)	
	Designation		ZST 600-334-1000-R11; optionally with INIRA®	
Lubrication system ⁴⁾	Set consisting of lubrication pinion and axis for	Rack	LMT 600-PU -17L1-060-1	
		Pinion	LMT 600-PU -17R1-060-1	
	Lubricator	125 cm ³	LUC+125-0511-02	
		400 cm ³	LUC+400-0511-02	
	Lubricant		WITTENSTEIN alpha G11	

¹⁾ Maximum feed force depending on ratio and number of stages

²⁾ Calculation with lowest ratio and maximum input speed

³⁾ Single-stage also available

⁴⁾ Impulse-controlled basic version with one output and 2 m hose. See page 116 for further information on the lubrication system.

Application-specific dimensioning with cymex® – www.wittenstein-cymex.com

Alternative system solutions

Pinion			Axis distance	RP+ 060S	RPM+ 060S	RPC+ 060S	RPK+ 060S	Rack
Designation	d [mm]	x []	A [mm]	F_{zT} [N]	F_{zT} [N]	F_{zT} [N]	F_{zT} [N]	Designation
RMW 500-444-23L1-106	122.019	0	95.009	47000	47000	47000	47000	ZST 500-334-1000-R11; optionally with INIRA®
RMW 500-444-30L1-106	159.155	0	113.578	39400	39400	39400	39400	ZST 500-334-1000-R11; optionally with INIRA®
RMW 600-444-19L1-106	120.958	0.4	105.879	47200	47200	47200	47200	ZST 600-333-1000-R1; optionally with INIRA®
RMW 600-444-23L1-128	146.423	0	116.211	75000	75000	75000	75000	ZST 600-334-1000-R11; optionally with INIRA®
RMW 600-444-28L1-128	178.254	0	132.127	61500	61500	61500	61500	ZST 600-334-1000-R11; optionally with INIRA®

d = Pitch circle diameter

x = Addendum modification coefficient

A = Distance between pinion axle and rear surface of rack

F_{zT} = Maximum feed force depending on ratio and number of stages

RPM+ available in customized version

Application-specific dimensioning with cymex® – www.wittenstein-cymex.com

2-stage

up to 48⁴⁾ (M)
clamping hub
diameters

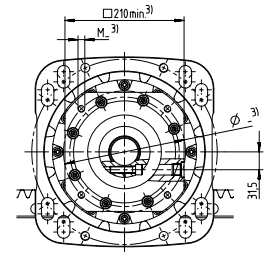
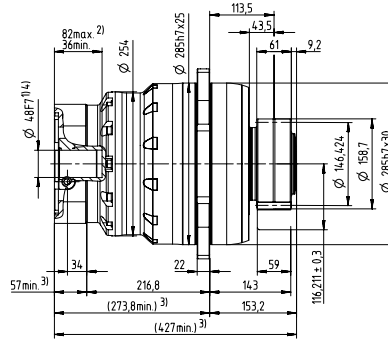
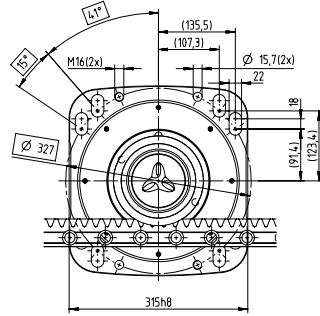

3-stage

up to 38⁴⁾ (K)
clamping hub
diameters

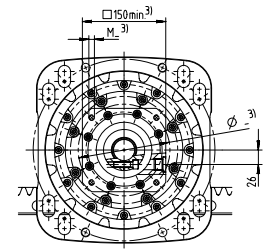
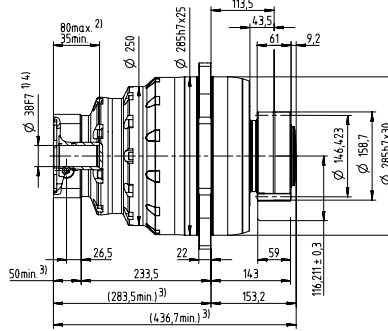
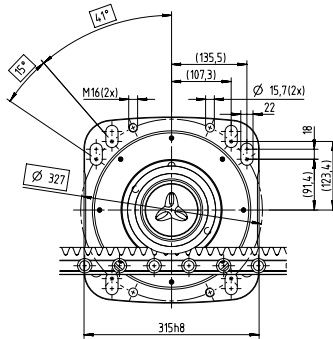

Motor shaft diameter [mm]

Non-tolerated dimensions are nominal dimensions
Detailed rack dimensions starting on page 151

¹⁾ Check motor shaft fit

²⁾ Min./Max. permissible motor shaft length. Longer motor shafts are possible, please contact alpha.

³⁾ The dimensions depend on the motor

⁴⁾ Smaller motor shaft diameter is compensated by a bushing with a minimum thickness of 1 mm

Premium Linear System PLS 112 with RP+

Planetary gearbox RP+ 080 MA with rack module 8 and pinion RMW module 8

System	Max. feed force ¹⁾ F_{2T}		112000 N	
	Max. feed speed ²⁾ v_{max}		111 m/min	37 m/min
Gearbox	No. of stages ³⁾		2	3
	Ratios i		22 / 27.5 / 38.5 / 55	66 / 88 / 110 / 154 / 220
	Clamping hub diameter		48 mm	38 / 48 mm
	Designation		RP 080S-MA2-_-_-_-3_ _	RP 080S-MA3-_-_-_-3_ _
Pinion	Module m		8 mm	
	Number of teeth z		21	
	Pitch circle diameter d		178.254 mm	
	Profile correction factor x		0.2	
	Helix angle β		-19.5283° (left-handed)	
	Designation		RMW 800-444-21L1-156	
Rack	Module m		8 mm	
	Lengths L		960 mm	
	Helix angle β		19.5283° (right-handed)	
	Designation		ZST 800-334- 960-R11; optionally with INIRA®	
Lubrication system ⁴⁾	Set consisting of lubrication pinion and axis for	Rack	LMT 800-PU -17L1-080-1	
		Pinion	LMT 800-PU -17R1-080-1	
	Lubricator	125 cm ³	LUC+125-0511-02	
		400 cm ³	LUC+400-0511-02	
	Lubricant		WITTENSTEIN alpha G11	

¹⁾ Maximum feed force depending on ratio and number of stages

²⁾ Calculation with lowest ratio and maximum input speed

³⁾ Single-stage also available

⁴⁾ Impulse-controlled basic version with one output and 2 m hose. See page 116 for further information on the lubrication system.

Application-specific dimensioning with cymex® – www.wittenstein-cymex.com

Alternative system solutions

Pinion			Axis distance	RP+ 080S	RPM+ 080S	RPC+ 080S	RPK+ 080S	Rack
Designation	d [mm]	x []	A [mm]	F_{2T} [N]	F_{2T} [N]	F_{2T} [N]	F_{2T} [N]	Designation
RMW 600-444-23L1-128	146.423	0	116.211	75000	75000	75000	75000	ZST 600-334-1000-R11; optionally with INIRA®
RMW 600-444-28L1-128	178.254	0	132.127	64500	64500	64500	64500	ZST 600-334-1000-R11; optionally with INIRA®
RMW 800-444-21L1-156	178.254	0.2	161.727	112000	112000	112000	112000	ZST 800-334- 960-R11; optionally with INIRA®

d = Pitch circle diameter

x = Addendum modification coefficient

A = Distance between pinion axle and rear surface of rack

F_{2T} = Maximum feed force depending on ratio and number of stages

RPM+ available in customized version

Application-specific dimensioning with cymex® – www.wittenstein-cymex.com

2-stage

up to 48⁴⁾ (M)
clamping hub
diameters

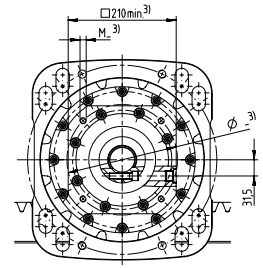
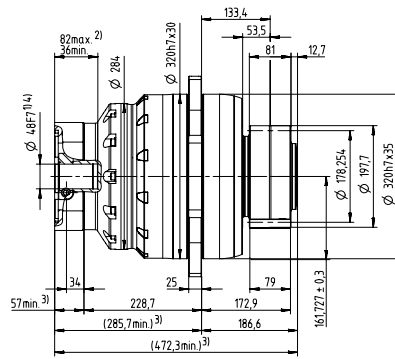
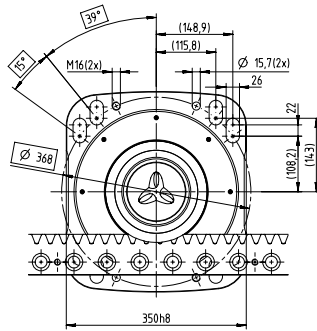

3-stage

up to 38⁴⁾ (K)
clamping hub
diameters

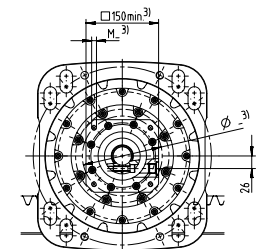
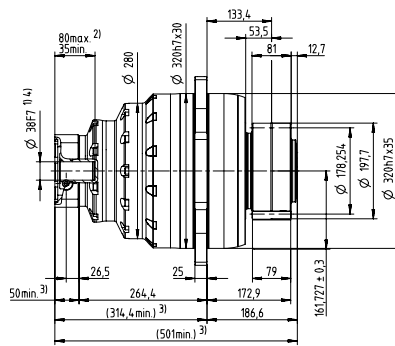
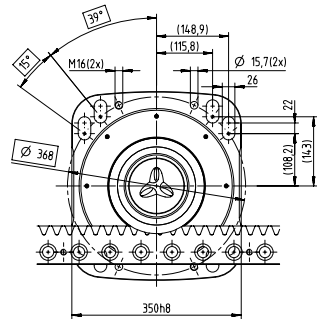

Motor shaft diameter [mm]

up to 48⁴⁾ (M)
clamping hub
diameters

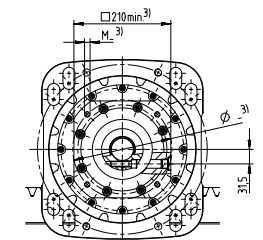
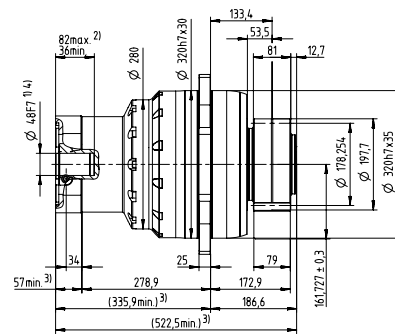
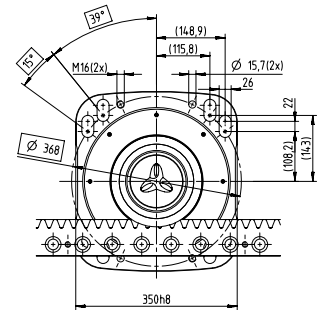

Non-tolerated dimensions are nominal dimensions
Detailed rack dimensions starting on page 151

¹⁾ Check motor shaft fit

²⁾ Min./Max. permissible motor shaft length. Longer motor shafts are possible, please contact alpha.

³⁾ The dimensions depend on the motor

⁴⁾ Smaller motor shaft diameter is compensated by a bushing with a minimum thickness of 1 mm