

Application-specific solutions

HYGIENIC DESIGN HDV

Our Hygienic Design products are specially developed for unusual fields of application in food processing. They are made with highly resistant stainless steel and ideally suited for cleaning with aggressive cleaning agents and disinfectants. Direct process integration allows new design freedom and an open machine concept without encasings.



The world's first
EHEDG-certified
planetary gearbox

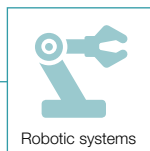

Robotic systems



Food and drinks industry

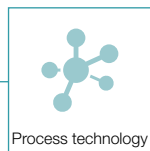

Process technology



Cosmetics



Pharmaceuticals

AREAS OF APPLICATION

HDV – Reliably Clean



HDV

Aseptic, highly dynamic, and outstanding positioning accuracy: the HDV is the world's first planetary gearbox with EHEDG certification and meets the strict hygiene requirements of production and packaging facilities. The gearbox in hygienic design not only offers you maximum safety against contamination-related product and process risks, but also guarantees maximum plant availability and productivity of the equipment.

PRODUCT HIGHLIGHTS



New design freedom

Direct process integration opens up new design options.



Resistance

Resistant against chemical cleaning agents and disinfectants.



Cleaning

Fast, efficient, and safe cleaning, also suitable for CIP processes.

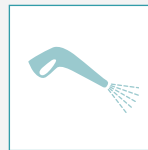

Max. achievable impermeability

IP69X (max. 30 bar).
Relating to DIN 60529:2014-09



The world's first
EHEDG-certified
planetary gearbox



Pharmaceuticals – bottling plant for liquid pharmaceutical products



Cosmetics – bottling plant for creams



More information about the HDV: simply scan the QR code using your smartphone.
www.wittenstein.de/en-en/hygienic-design/



A Certification

- World's first EHEDG-certified planetary gearbox
- FDA certified
- NSF certified

D Maximum safety

- Triple sealing concept
- Seals resistant to cleaning agents
- IP69X (max. 30 bar)

B Surface texture

- Smooth-rolled surface made of hygienic steel 1.4404
- Electropolished surface also optionally possible

C Cavity-free housing design

- No undercuts
- Large radii
- No horizontal surfaces



Sweet goods – packaging plant for cookies



Milk products – cheese processing plant

HDV 015 MF 1-/2-stage

			1-stage				2-stage							
Ratio	i		4	5	7	10	16	20	25	35	50	70	100	
Max. torque ^{a) b) e)}	T_{2a}	Nm	51	51	51	46	51	51	51	51	51	51	46	
		in.lb	451	451	451	407	451	451	451	451	451	451	407	
Max. acceleration torque ^{e)} (max. 1000 cycles per hour)	T_{2B}	Nm	32	32	32	29	32	32	32	32	32	32	29	
		in.lb	283	283	283	257	283	283	283	283	283	283	257	
Emergency stop torque ^{a) b) e)} (permitted 1000 times during the service life of the gearbox)	T_{2Not}	Nm	75	75	75	75	75	75	75	75	75	75	75	
		in.lb	664	664	664	664	664	664	664	664	664	664	664	
Permitted average input speed ^{d)} (at T_{2a} and 20 °C ambient temperature)	n_{1N}	rpm	3000	3000	3000	3000	3700	3700	3700	3700	3700	3700	3700	
Max. input speed	n_{1Max}	rpm	6000	6000	6000	6000	6000	6000	6000	6000	6000	6000	6000	
Mean no load running torque ^{b)} (at $n_1=3000$ rpm and 20 °C gearbox temperature)	T_{012}	Nm	0.15	0.15	0.15	0.15	0.15	0.15	0.15	0.15	0.15	0.15	0.15	
		in.lb	1.3	1.3	1.3	1.3	1.3	1.3	1.3	1.3	1.3	1.3	1.3	
Max. backlash	j_t	arcmin	≤ 10				≤ 15							
Torsional rigidity ^{b)}	C_{t21}	Nm/arcmin	2.3	2.3	2.3	2	2.3	2.3	2.3	2.3	2.3	2.3	2	
		in.lb/arcmin	20	20	20	18	20	20	20	20	20	20	18	
Max. axial force ^{c)} (Standard / HIGH FORCES)	F_{2AMax}	N	500 / 1000				500 / 1000							
		lb _f	113 / 225				113 / 225							
Max. lateral force ^{c)} (Standard / HIGH FORCES)	F_{2QMax}	N	350 / 1600				350 / 1600							
		lb _f	79 / 360				79 / 360							
Max. tilting moment (Standard / HIGH FORCES)	M_{2KMax}	Nm	20 / 105				20 / 105							
		in.lb	177 / 929				177 / 929							
Efficiency at full load	η	%	97				95							
Service life	L_n	h	> 20000				> 20000							
Weight (incl. standard adapter plate)	m	kg	3.2				3.8							
		lb _m	7.1				8.4							
Operating noise (at reference ratio and reference speed – ratio-specific values available in cymex®)	L_{PA}	dB(A)	≤ 60				≤ 60							
Max. permitted housing temperature		°C	+90				+90							
		°F	+194				+194							
Ambient temperature		°C	-25 to +40				-25 to +40							
		°F	-13 to +104				-13 to +104							
Lubrication			Lubricated for life											
Direction of rotation			In- and output same direction											
Protection class			IP 69X											
Mass moment of inertia (relates to the drive) Clamping hub diameter [mm]	C	14	J_1	kgcm ²	0.18	0.17	0.15	0.15	0.17	0.16	0.16	0.15	0.15	0.15
				10 ⁻³ in.lb.s ²	0.16	0.15	0.13	0.13	0.15	0.14	0.14	0.13	0.13	0.13

Please use our sizing software cymex® for a detailed sizing – www.wittenstein-cymex.com

^{a)} Valid for torque transmission only

^{b)} Valid for standard clamping hub diameter

^{c)} Refers to center of the output shaft or flange

^{d)} Please reduce input speed at higher ambient temperatures

^{e)} Valid for: Smooth shaft

1-stage

up to 14⁴⁾ (C)⁵⁾
clamping hub
diameter

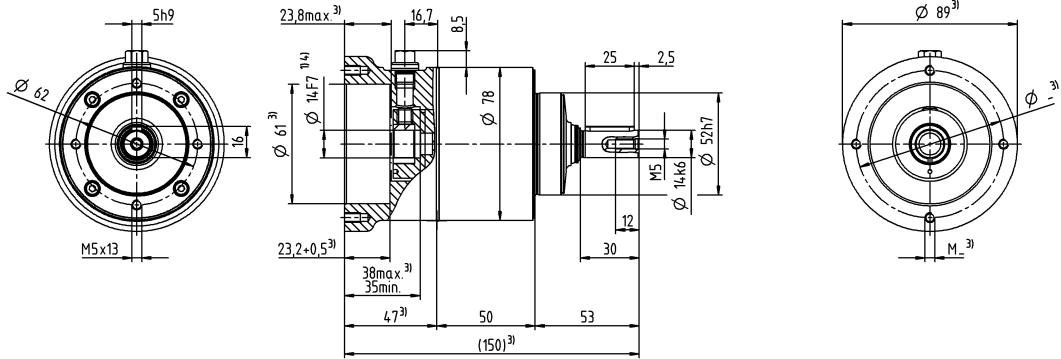

2-stage

up to 14⁴⁾ (C)⁵⁾
clamping hub
diameter

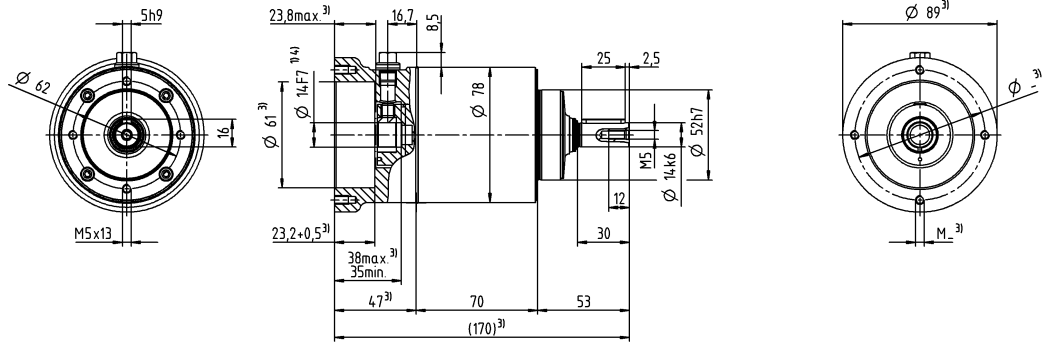

Motor shaft diameter [mm]

Other output variants

Smooth shaft

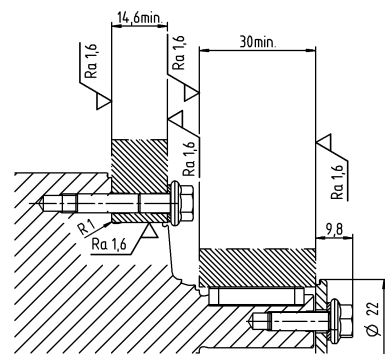
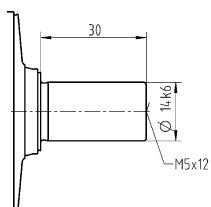

Mounting accessories:
Mounting kit comprising stainless steel screws, washers, seals and O-rings available as an option.

- Non-tolerated dimensions are nominal dimensions
- ¹⁾ Check motor shaft fit
- ²⁾ Min. / Max. permissible motor shaft length
Longer motor shafts are possible, please contact alpha
- ³⁾ The dimensions depend on the motor
- ⁴⁾ Smaller motor shaft diameter is compensated by a bushing with a minimum thickness of 1 mm
- ⁵⁾ Standard clamping hub diameter

HDV 025 MF 1-/2-stage

			1-stage				2-stage								
Ratio	i		4	5	7	10	16	20	25	35	50	70	100		
Max. torque ^{a) b) e)}	T_{2a}	Nm	128	128	128	115	128	128	128	128	128	128	115		
		in.lb	1133	1133	1133	1018	1133	1133	1133	1133	1133	1133	1018		
Max. acceleration torque ^{e)} (max. 1000 cycles per hour)	T_{2B}	Nm	80	80	80	72	80	80	80	80	80	80	72		
		in.lb	708	708	708	637	708	708	708	708	708	708	637		
Emergency stop torque ^{a) b) e)} (permitted 1000 times during the service life of the gearbox)	T_{2Not}	Nm	190	190	190	190	190	190	190	190	190	190	190		
		in.lb	1682	1682	1682	1682	1682	1682	1682	1682	1682	1682	1682		
Permitted average input speed ^{d)} (at T_{2a} and 20 °C ambient temperature)	n_{1N}	rpm	2700	2700	2700	2700	3400	3400	3400	3400	3400	3400	3400		
Max. input speed	n_{1Max}	rpm	6000	6000	6000	6000	6000	6000	6000	6000	6000	6000	6000		
Mean no load running torque ^{b)} (at $n_1=3000$ rpm and 20 °C gearbox temperature)	T_{012}	Nm	0.3	0.3	0.3	0.3	0.3	0.3	0.3	0.3	0.3	0.3	0.3		
		in.lb	2.7	2.7	2.7	2.7	2.7	2.7	2.7	2.7	2.7	2.7	2.7		
Max. backlash	j_1	arcmin	≤ 10				≤ 15								
Torsional rigidity ^{b)}	C_{121}	Nm/arcmin	7.5	7.5	7.5	5.5	7.5	7.5	7.5	7.5	7.5	7.5	7.5	5.5	
		in.lb/arcmin	66	66	66	49	66	66	66	66	66	66	66	49	
Max. axial force ^{c)} (Standard / HIGH FORCES)	F_{2AMax}	N	500 / 1500				500 / 1500								
		lb _f	113 / 338				113 / 338								
Max. lateral force ^{c)} (Standard / HIGH FORCES)	F_{2QMax}	N	500 / 2500				500 / 2500								
		lb _f	113 / 563				113 / 563								
Max. tilting moment (Standard / HIGH FORCES)	M_{2KMax}	Nm	31 / 185				31 / 185								
		in.lb	274 / 1637				274 / 1637								
Efficiency at full load	η	%	97				95								
Service life	L_n	h	> 20000				> 20000								
Weight (incl. standard adapter plate)	m	kg	5.2				6.5								
		lb _m	11				14								
Operating noise (at reference ratio and reference speed – ratio-specific values available in cymex®)	L_{PA}	dB(A)	≤ 63				≤ 63								
Max. permitted housing temperature		°C	+90				+90								
		°F	+194				+194								
Ambient temperature		°C	-25 to +40				-25 to +40								
		°F	-13 to +104				-13 to +104								
Lubrication			Lubricated for life												
Direction of rotation			In- and output same direction												
Protection class			IP 69X												
Mass moment of inertia (relates to the drive) Clamping hub diameter [mm]	E	19	J_1	kgcm ²	0.63	0.54	0.52	0.46	0.6	0.52	0.54	0.5	0.52	0.52	0.46
				10 ⁻³ in.lb.s ²	0.56	0.48	0.46	0.41	0.53	0.46	0.48	0.44	0.46	0.46	0.41

Please use our sizing software cymex® for a detailed sizing – www.wittenstein-cymex.com

^{a)} Valid for torque transmission only

^{b)} Valid for standard clamping hub diameter

^{c)} Refers to center of the output shaft or flange

^{d)} Please reduce input speed at higher ambient temperatures

^{e)} Valid for: Smooth shaft

1-stage

up to 19⁴⁾ (E⁵⁾
clamping hub
diameter

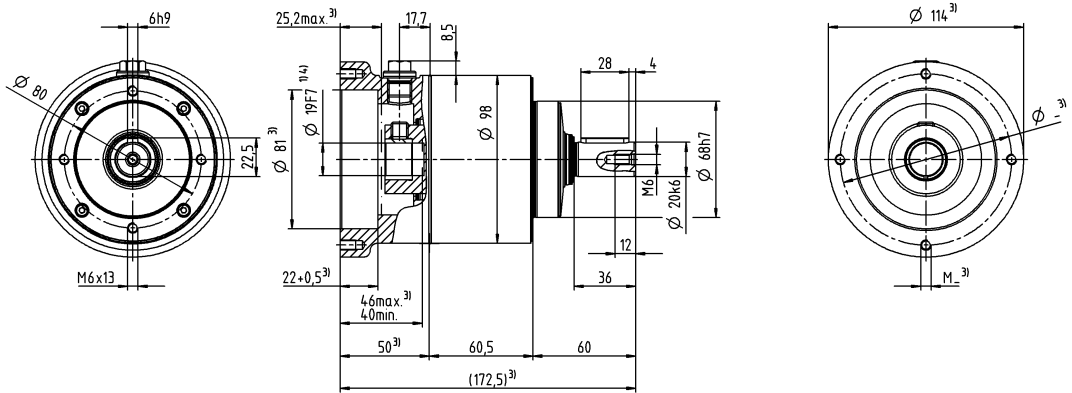

2-stage

up to 19⁴⁾ (E⁵⁾
clamping hub
diameter

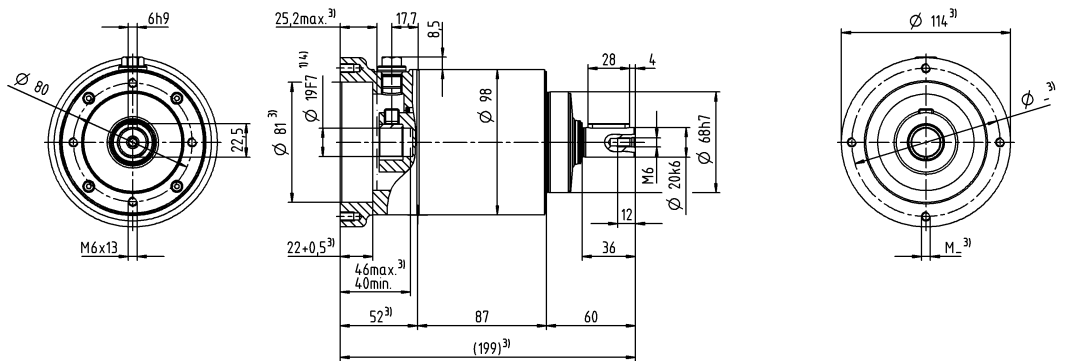

Motor shaft diameter [mm]

Other output variants

Smooth shaft

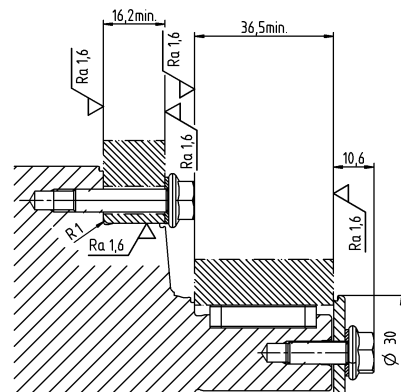
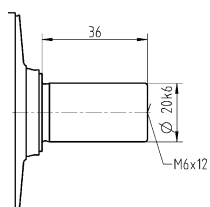

Mounting accessories:
Mounting kit comprising stainless steel screws, washers, seals and O-rings available as an option.

- Non-tolerated dimensions are nominal dimensions
- ¹⁾ Check motor shaft fit
- ²⁾ Min. / Max. permissible motor shaft length
Longer motor shafts are possible, please contact alpha
- ³⁾ The dimensions depend on the motor
- ⁴⁾ Smaller motor shaft diameter is compensated by a bushing with a minimum thickness of 1 mm
- ⁵⁾ Standard clamping hub diameter

HDV 035 MF 1-/2-stage

			1-stage				2-stage								
Ratio	i		4	5	7	10	16	20	25	35	50	70	100		
Max. torque ^{a) b) e)}	T_{2a}	Nm	320	320	320	288	320	320	320	320	320	320	288		
		in.lb	2832	2832	2832	2549	2832	2832	2832	2832	2832	2832	2832	2549	
Max. acceleration torque ^{e)} (max. 1000 cycles per hour)	T_{2B}	Nm	200	200	200	180	200	200	200	200	200	200	180		
		in.lb	1770	1770	1770	1593	1770	1770	1770	1770	1770	1770	1770	1593	
Emergency stop torque ^{a) b) e)} (permitted 1000 times during the service life of the gearbox)	T_{2Not}	Nm	480	480	480	480	480	480	480	480	480	480	480		
		in.lb	4248	4248	4248	4248	4248	4248	4248	4248	4248	4248	4248	4248	
Permitted average input speed ^{d)} (at T_{2a} and 20 °C ambient temperature)	n_{1N}	rpm	2000	2000	2000	2000	2600	2600	2600	2600	2600	2600	2600		
Max. input speed	n_{1Max}	rpm	4800	4800	4800	4800	4800	4800	4800	4800	4800	4800	4800		
Mean no load running torque ^{b)} (at $n_1=3000$ rpm and 20 °C gearbox temperature)	T_{012}	Nm	0.5	0.5	0.5	0.5	0.5	0.5	0.5	0.5	0.5	0.5	0.5		
		in.lb	4.4	4.4	4.4	4.4	4.4	4.4	4.4	4.4	4.4	4.4	4.4	4.4	
Max. backlash	j_1	arcmin	≤ 10				≤ 15								
Torsional rigidity ^{b)}	C_{012}	Nm/arcmin	24	24	24	24	24	24	24	24	24	24	24		
		in.lb/arcmin	212	212	212	212	212	212	212	212	212	212	212	212	
Max. axial force ^{c)} (Standard / HIGH FORCES)	F_{2AMax}	N	1700 / 3000				1700 / 3000								
		lb _f	383 / 675				383 / 675								
Max. lateral force ^{c)} (Standard / HIGH FORCES)	F_{2QMax}	N	1200 / 4250				1200 / 4250								
		lb _f	270 / 956				270 / 956								
Max. tilting moment (Standard / HIGH FORCES)	M_{2KMax}	Nm	95 / 407				95 / 407								
		in.lb	841 / 3602				841 / 3602								
Efficiency at full load	η	%	97				95								
Service life	L_n	h	> 20000				> 20000								
Weight (incl. standard adapter plate)	m	kg	13.6				16.6								
		lb _m	30				37								
Operating noise (at reference ratio and reference speed – ratio-specific values available in cymex®)	L_{PA}	dB(A)	≤ 68				≤ 68								
Max. permitted housing temperature		°C	+90				+90								
		°F	+194				+194								
Ambient temperature		°C	-25 to +40				-25 to +40								
		°F	-13 to +104				-13 to +104								
Lubrication			Lubricated for life												
Direction of rotation			In- and output same direction												
Protection class			IP 69X												
Mass moment of inertia (relates to the drive) Clamping hub diameter [mm]	G	24	J_1	kgcm ²	2.6	2.3	2	1.8	2.3	2.1	2.1	1.9	1.8	1.8	1.8
				10 ⁻³ in.lb.s ²	2.3	2	1.8	1.6	2	1.9	1.9	1.7	1.6	1.6	1.6

Please use our sizing software cymex® for a detailed sizing – www.wittenstein-cymex.com

^{a)} Valid for torque transmission only

^{b)} Valid for standard clamping hub diameter

^{c)} Refers to center of the output shaft or flange

^{d)} Please reduce input speed at higher ambient temperatures

^{e)} Valid for: Smooth shaft

1-stage

up to 24⁴⁾ (G)⁵⁾
clamping hub diameter

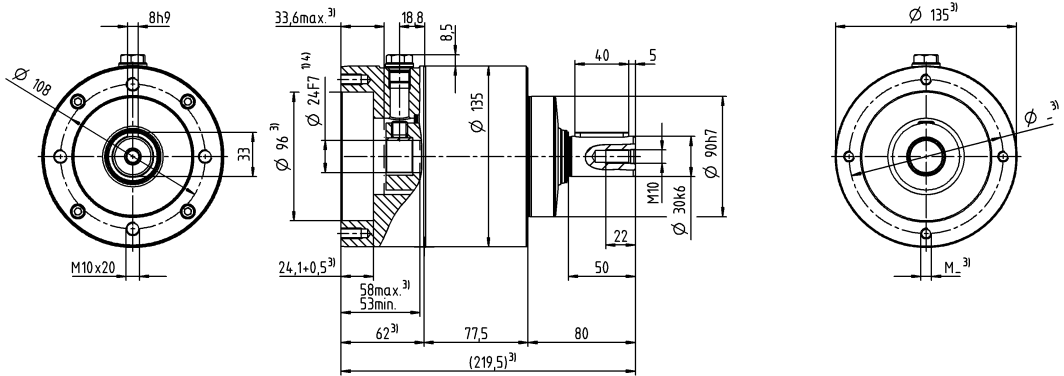

2-stage

Motor shaft diameter [mm]

up to 24⁴⁾ (G)⁵⁾
clamping hub diameter

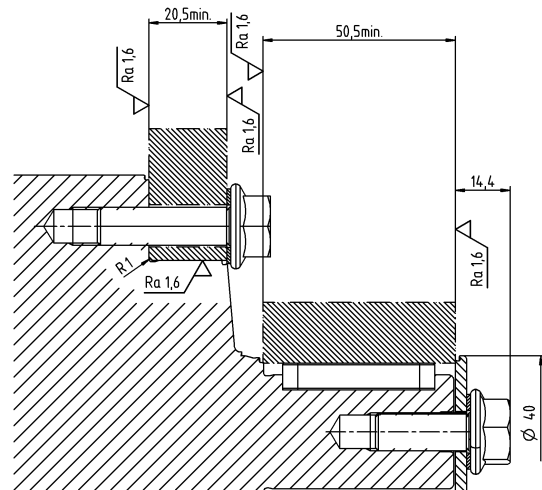
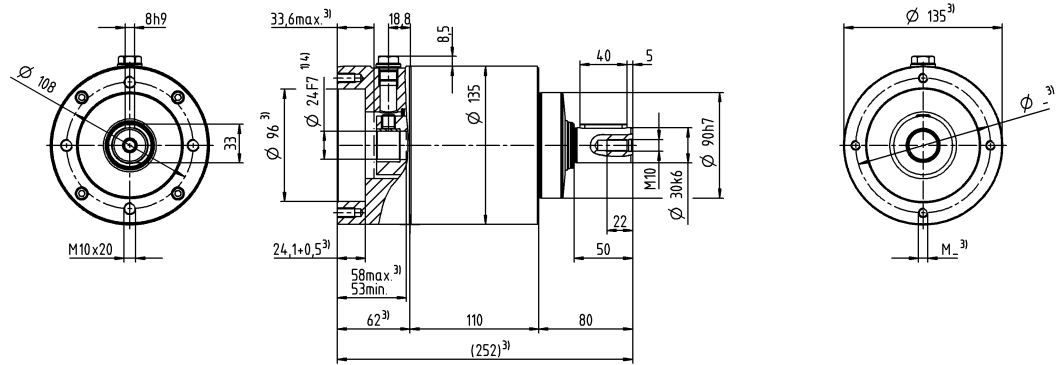

Other output variants

Smooth shaft

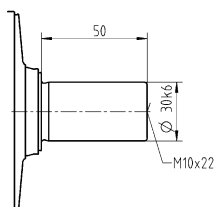

Mounting accessories:

Mounting kit comprising stainless steel screws, washers, seals and O-rings available as an option.

Non-tolerated dimensions are nominal dimensions

¹⁾ Check motor shaft fit

²⁾ Min. / Max. permissible motor shaft length

Longer motor shafts are possible, please contact alpha

³⁾ The dimensions depend on the motor

⁴⁾ Smaller motor shaft diameter is compensated by a bushing with a minimum thickness of 1 mm

⁵⁾ Standard clamping hub diameter