

Energy Chain

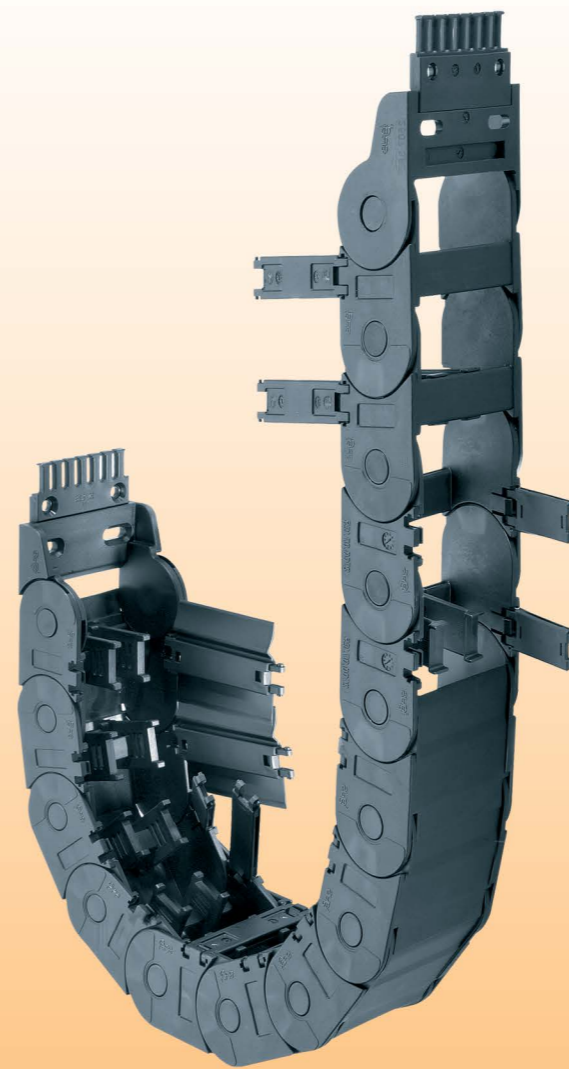

Universal applications for igus® Energy Chains®

- Multitude of possibilities in terms of movement and length
- Carry sensitive bus, data cables, fibre optic cables and energy sources such as electricity, gas, air and liquids
- Accommodate very high dynamic loads and stringent service life requirements
- Handle very different environments and climatic zones
- Space-saving installation
- High levels of acceleration can be achieved
- Simple assembly of modular system on site and rapid retrofitting of cables possible

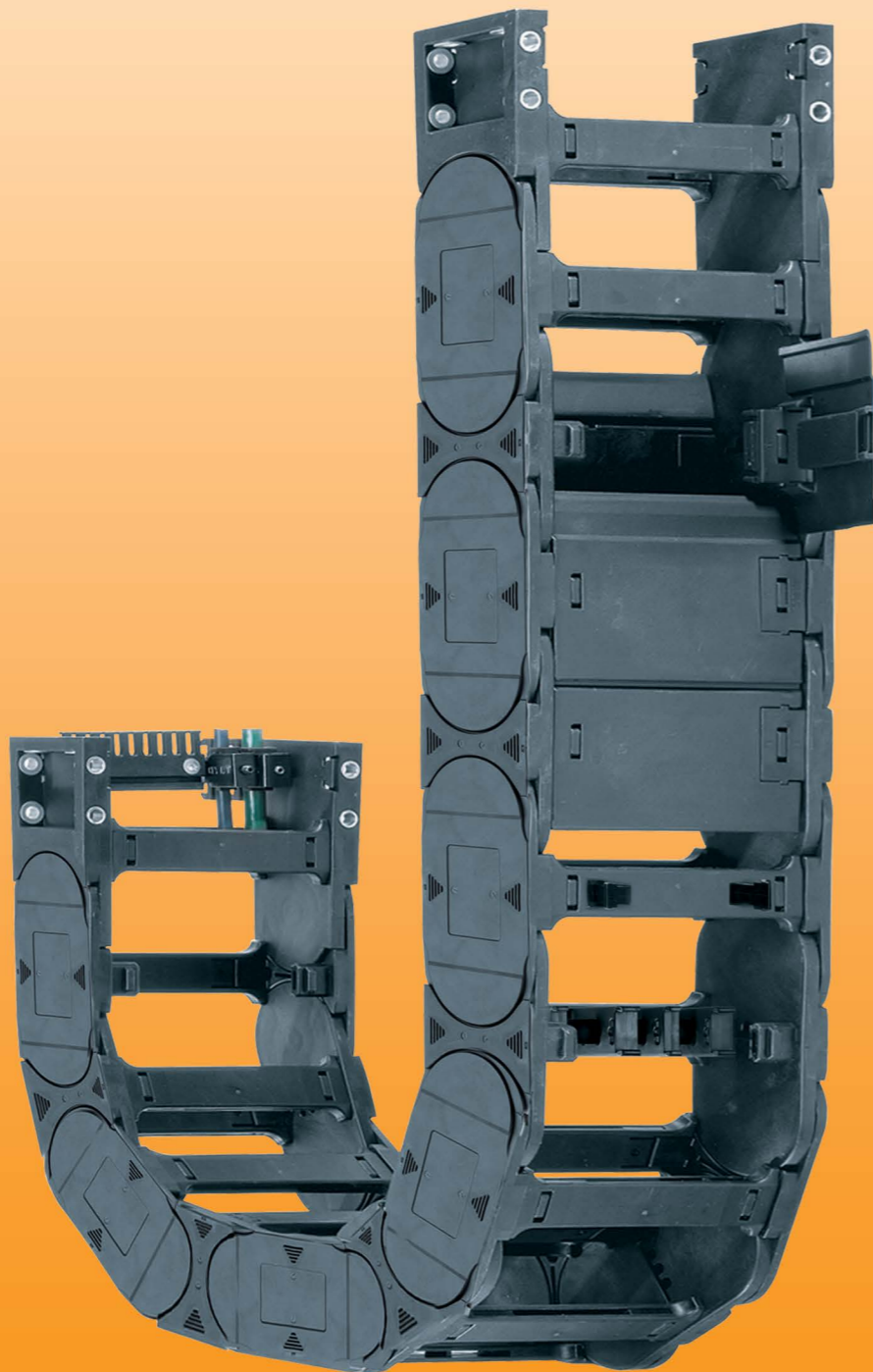

Moving energy made easy – for any industry

Solutions with igus® e-chain systems®
 The task of igus® e-chain systems® is to reliably supply energy and data to moving equipment. Such equipment is constantly in motion and has to function reliably in difficult ambient conditions as well as under high loads and at high speeds. e-chain systems® can be used universally in these kinds of application.



For example: machine tools, woodworking equipment, cranes, material handling systems and robots ...

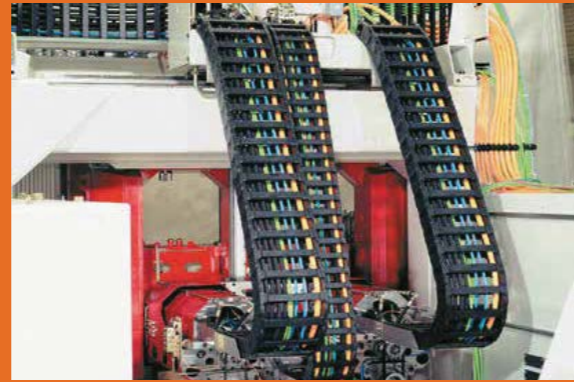

Harnessed "readychain" energy chains reduce costs sustainably



The worldwide longest e-chain travel of 615m with igus® rol e-chains® and chainflex® cables in a power plant



igus® e-chain systems® replace conventional energy supply solutions for cranes



Tunnelling machine - reliable E4.1 energy supply in spite of dirt and vibration



Long travel, side-mounted installation using the vibration-free and low noise series E6.29 in a camera application



igus® triflex® R e-chains® for robots that machine moulded plastic parts



The world's largest plastic e-chain® (as of 05/2015), the igus® E4.1 series E4.350. Equipped with rollers, it travels reliably and energy efficiently. In this case on a slurry vacuum application. 150m travel, 100kg/m filling weight

Contents

Design Information, Application icons, Selection guide				130-137
E2 micro Series 06		10,5		138-139
E2 micro Series E2.10, E2i.10, E2C.10		10,5		140-141
E2 mini Series 10		18		142-143
Easy Chain® Series E08-Z08		14,7		144-145
E2 Micro Series E2.15, E2i.15, E2C.15		14,4		146-147
E2/000 Series 1400,1500		21		148-151
E2.1 E2i.26-E2.26 Strong all rounder		25		152-157
E2.1 E2i.38-E2.38		35		158-161
E2.1 E2i.48-E2.48		45		162-167
E2 E-Tubes Series R48		25		168-170
E4.1 Light Series E4.31L		31		171-173
E4.1 Series E4.42			42	174-175
E4 Light Series 14240			62	176-179
E4.1 Series E4.56			56	180-183
E4.1 Series E4.80			80	184-187

Green = Low Duty

Yellow = Medium Duty

Orange = Heavy Duty

Red = Extra Heavy Duty

Guide Troughs		188-189
Triflex-R 3D-E-Chain® for robotic applications		190-191
Triflex-R TRC-TRE-TRL Mounting Brackets		192-193
Additional product outlines		194-195

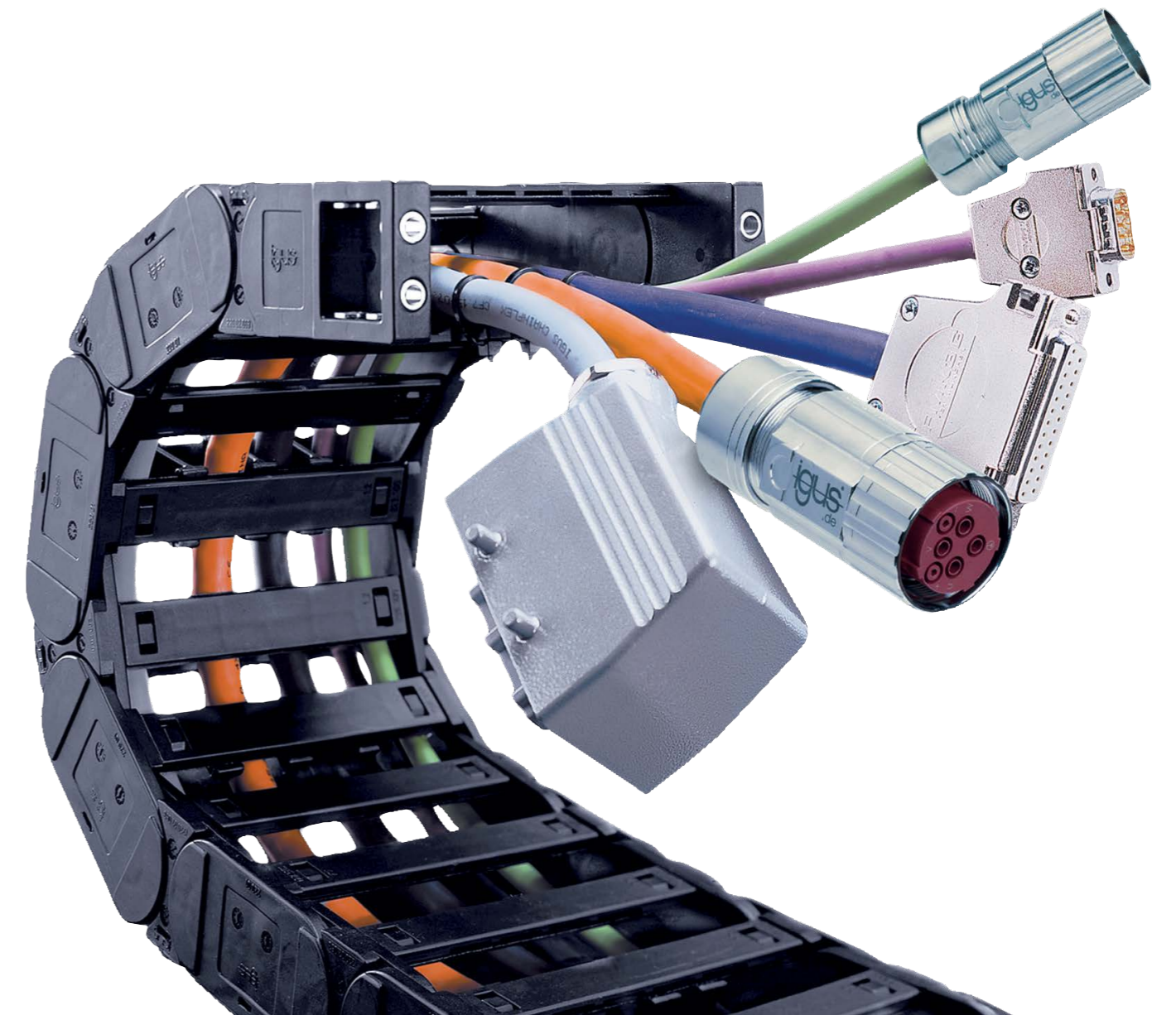

the-chain | Designing with igus®

the-chain - moving energy made easy - an all-in-one energy supply system

There are many ways to supply your equipment and systems with energy and data. But there is no solution as universal and durable as the e-chain system®. Whether you have a circular movement, a hanging or standing application, a long travel distance or high loads - igus® plastic e-chains® will help you solve nearly any type of energy supply problem, quickly, safely and with ease. By using the extensive igus® construction kit, you will find the solution to match your needs and application: from individual components to a complete installation at your facility. We have developed an online tool to help you find what you need with greater ease www.igus.eu/the-chain. Should you have trouble finding exactly the product you need, our engineers are always at your disposal to help you design the-chain.



The igus® lab and field experience

Our calculations and analyses are based on the result of ongoing practical tests in our technical centre and our experience with moving applications. The focal points of our tests are push/pull forces, friction values and abrasion under widely varying conditions and speeds, as well as factors such as dirt, weathering or impact. We test all system components such as cables, hoses, strain relief and other accessories, in addition to the e-chains® or e-tubes and guide troughs.

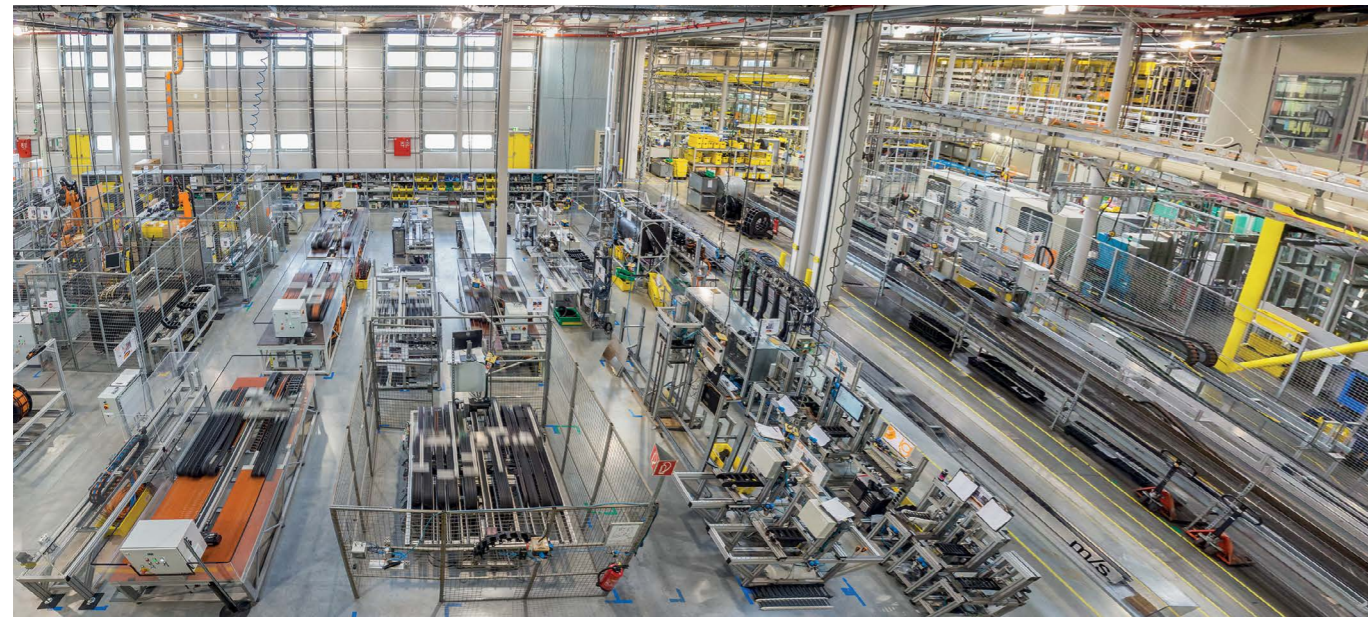

2,750m² igus® test lab - more than 15,000 tests every year

Design Information

Calculation of chain length

If the fixed end of the Energy Chain® is located in the centre of the travel, the chain length "L_C" is calculated by using half the length of travel and adding the value "K" for the curved length. (You can obtain the value "K" from the table in the catalogue.) Placing the fixed end in the centre of the travel is the most cost-effective solution because it requires the shortest Energy Chain®, cables and hoses.

Fixed end in the centre of the travel is the most favourable solution

$$L_C = \frac{S}{2} + K$$

This formula is generally valid for all types of applications if the fixed end is in the centre of the travel. Exceptions: rotary movements and most long travels.

- L_C = chain length
- S = length of travel
- K = add-on length for bending radius (You can obtain the value "K" from the tables in the catalogue)
- R = bending radius

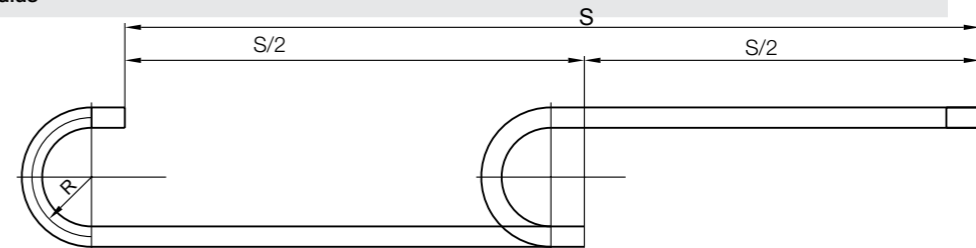

Camber

"Camber" is the curve of the upper run along its unsupported length. All igus® Energy Chains® are manufactured with camber. In the Installation Dimensions section of each respective Energy Chain® description, you will find the measurement H_F, which specifies the necessary clearance height, taking the camber into account. The camber allows for longer unsupported length and increases service life and operating safety. Upon request, we can deliver Energy Chains® without camber for restricted space applications; however, these "no-camber" chains do not have the same load-bearing capacity. Please consult Treotham.

- H = nominal clearance height
- H_F = required clearance height

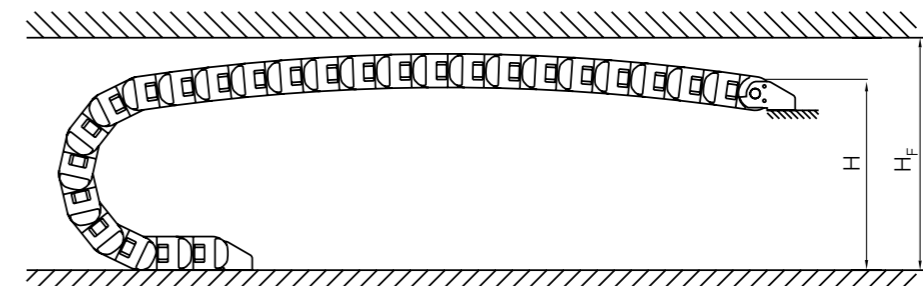

Principle of camber for igus® Energy Chains® H_F = required installation height.

Application icons

2 Accessibility of e-chains® and e-tubes

	"easy" design - simply press cables in		One-piece, non-openable		Lids removable along the outer radius		trifflex® R - fully enclosed design, non openable
	Zipper - zip-open along the outer radius		Crossbars openable along the outer radius, from both sides		Crossbars removable along the inner and outer radius		trifflex® R - "easy" design, simply press cables in
	Openable along the inner radius, from one side		Crossbars openable along the inner radius, from both sides		Openable from both sides - lids openable along the outer radius, from one side		trifflex® R - "easy" design, simply press cables in
	Openable along the outer radius, from one side		Lids removable along the outer radius		Easy filling from both sides with "easy" design		trifflex® R - with snap-lock mechanism

Application icons

	Unsupported		Recommended standard		igus® calculation
	Gliding		igus® information		Mounting brackets
	Vertical hanging		igus® order example		chainfix strain relief
	Vertical standing		igus® web www.igus.eu		Interior separation
	Zig-zag		igus® delivery time		Guide troughs
	Side-mounted		Order key		NC without pretension
	Circular movement		Temperature		Noise-optimised
	Horizontal and vertical		Speed / acceleration		Quick version
	Nested		UL Classification		ESD e-chains®
	Side by side		Weight		Cleanroom certificates
	Combined motion		Preferred series		if Design Award

Price index

● ● ● Low price category

● ● ● Medium price category

● ● ● Highest price category



Quicklinks

Quicklinks for more information and additional features on each page. Visit directly your chosen product online, e.g. ► www.igus.eu/E4.56 and you'll find more details, 3D CAD files, DXF files, PDF downloads, application examples and many more for your chosen igus® product.

Selection guide designing e-chains®

- Sizing e-chains®**
Determine the size of the e-chain® based on the specified installation space of your machine and/or of the selected filling (such as the number of cables/outer diameter of cable).
- Determine fill weight**
Determine fill weight of (cables and/or media hoses) in [kg/m] using chainflex® quick selection for manufacturer specification.
- Determine length of travel**
Compare the fill weight calculated in (point 2) to the maximum fill weight of the selected e-chain® and check suitability for unsupported application.
- Unsupported length**
The maximum unsupported length initially depends on the fill weight and the e-chain® selected. At the same time, there are three different levels of unsupported length: 1 FL_G - recommended range of application 2 FL_B - permitted sag 3 Critical sag: should never be allowed! Twice the value of the unsupported length determines the maximum travel in the unsupported type of operation. For evaluation the weight of the cables to be carried must be known, then an exact choice can be made using a diagram on the introductory page of the selected product. You will find the values for FL_G and FL_B on the following pages in this chapter as an overview and within every individual series' chapter. They are necessary for: ● Finding the fill weight and length of travel for the appropriate e-chain® ● Identifying the maximum load of the e-chain® used.

If the application works self-supporting, then the selection follows the following criteria:

- Opening principle:** The quick finder gives an overview of the possibilities to fill the e-chain®.
- Bend radius R:** Determine the possible bend radius R [mm] of the e-chain® with respect to the cable diameter.
- Interior separation is possible with:** Separators Full-width shelves Shelves
- The price index gives you the possibility of making price comparisons of similar sizes within the range. **Low** ● ● ● **Medium** ● ● ● **High** ● ● ●
- Additional criteria:** ... for selection criteria such as pitch, permissible temperatures etc., please refer to our quick finder.

The following options are available if there is no possibility of self-supporting e-chain® application:

A You can choose the **next and stronger** e-chain®, that can be operated unsupported.

B **Option:** You can design your application to be **gliding**.

You can contact us directly or fax us your e-chain® requests! We will respond immediately!

Part No. e-chain®

Alternative e-chain®-dimensions:

hi:	Bi:	ha:	Ba:
Fill weight	[kg/m]		
Length of travel	[m]		

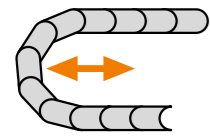

Unsupported | Short travels

2



The FL_G type of installation always generates the longest service life and can be operated with the max. values for speed and acceleration



Example for unsupported straight FL_G

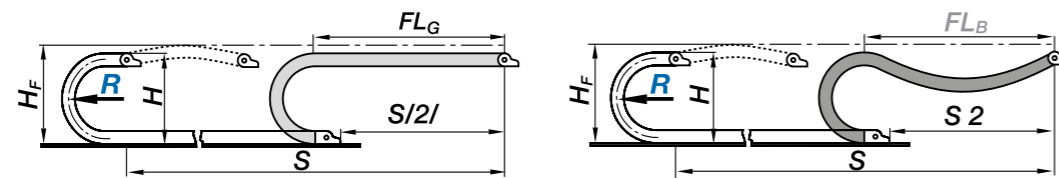

Unsupported applications

If the upper run of the e-chain® operates without touching the lower run over the entire travel, it is called an unsupported application. The distance between moving end and the beginning of the radius curve of the e-chain® is called the unsupported length. The unsupported application is the most common. igus® e-chains® are very well suited for high dynamics and long service life. The maximum unsupported length depends on the fill weight and the type of e-chain® or e-tube. As a result, we differentiate among three types of unsupported length:

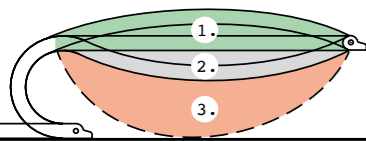

1. Unsupported with straight upper run FL_G
2. Unsupported with permitted sag FL_B
3. Critical sag

1. Unsupported with straight upper run FL_G

The e-chain® is unsupported FL_G when the upper run still has camber, is straight or has a maximum sag of 1/2 of the e-chain® link height. Installing the e-chain® in FL_G is always recommended. The e-chain® runs smoothly without additional vibration.

2. Unsupported with permitted sag FL_B

The e-chain® is unsupported FL_B when the sag is more than 1/2 e-chain® link height and less than the smallest available radius of this e-chain® series. In most applications the e-chain® can be used unsupported FL_B without any problems. There are restrictions concerning the maximum speed and acceleration.

3. Critical sag

When the sag of the e-chain® is higher than allowed for FL_B , it is in critical sag. Using an e-chain® in critical sag should be avoided or solved with special solutions. An e-chain® should never be installed with critical sag. Applications may reach critical sag after long service times. The e-chain® or e-tube should be replaced in these cases. Please contact us!

Unsupported | Short travels

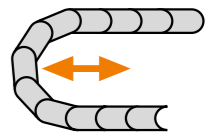

2



For every igus® e-chain® or e-tube, you will find the values for FL_G and FL_B in two locations: on the following pages in this chapter as an overview and within every individual series' chapter. They are essential for:

- Finding a suitable e-chain® for your fill weight and travel distance
- Identifying the maximum load for the selected e-chain®



Example of unsupported with sag, FL_B

What to do if the unsupported length is insufficient?

If your application, fill weight and travel fall outside the unsupported length parameters of the desired e-chain®, you have the following options:

- Select a stronger igus® e-chain®
- Support the e-chain® in the unsupported area. This option means restrictions for acceleration, speed and noise as a consequence - three fundamental examples are detailed to below - please consult igus® if you are considering this possibility - we will gladly provide you with a detailed proposal
- Use a multiband e-chain® or nest two igus® e-chains®
- inside one another. (Please consult igus®)
- Design the travel distance as a gliding application

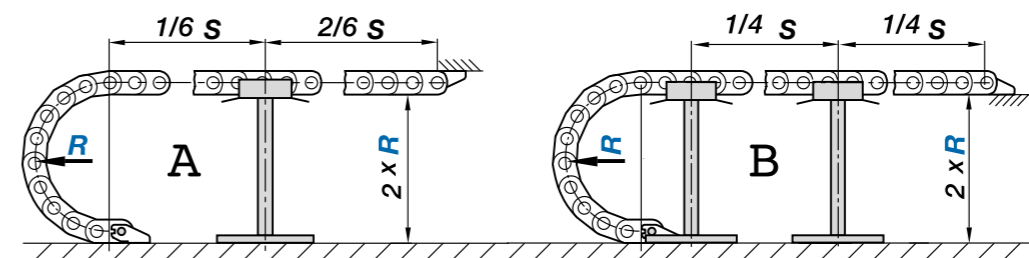

- Support of the FL_G area. A) The overall straight, unsupported travel can be increased here by a maximum of 50% of the FL_G and in case of option B) by a maximum of 100%

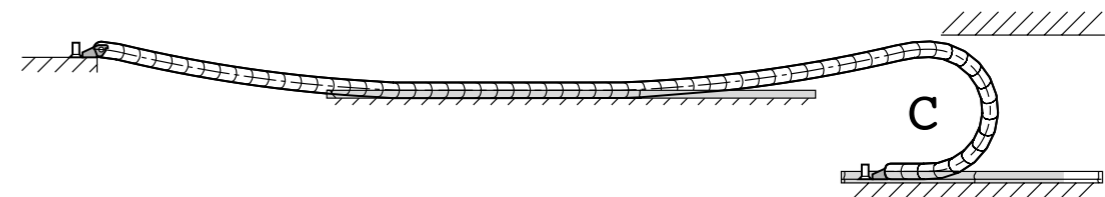

- Support of the FL_B area. C) The overall travel distance can be extended to a maximum of 100% from FL_B

Filling | Cable and Hose Packages

Reasons for distribution rules

The cables and hoses must be laid so that they can move freely at all times and so that no tensile force is exerted at the radius of the E-Chains®. For high-speed applications and high cycles, cables or hoses must not be laid on top of each other without horizontal separation. The standard values for this are: Travel speed over 0.5 m/s and cycles over 10,000 p.a. igus® interior separation offers a safe solution for this situation.

Further guidelines for distribution

The cable or hose weight should be symmetrically distributed along the width of the E-Chain®. Cables and hoses with different outer jacket materials must not be allowed to “stick” together. If necessary, they must be laid separately. All igus® Chainflex® cables can be combined with each and other brands of cable or hose. The cables and hoses should always be fixed at the moving end. The fixed end should always involve strain relief. Exceptions are made only for certain hydraulic hoses with length compensation issues or other high pressure hoses (i.e. hydraulic hoses).

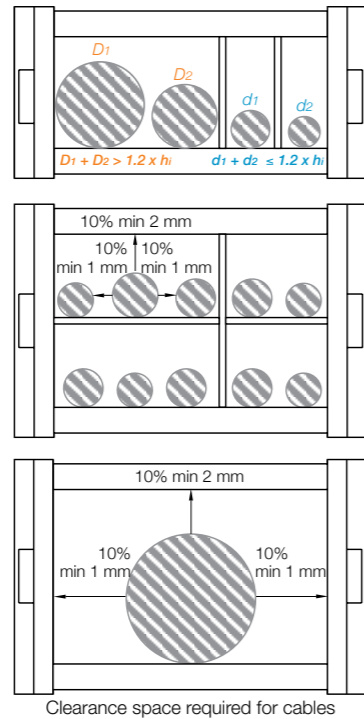

Distribution rules:

Case 1:

$D1 + D2 > 1.2 \times hi$

If $D1 + D2 > 1.2 \times$ E-Chain® inner height, no separation between the two cables or hoses is necessary. Two cables/hoses should never be left unguided on top of one another or be allowed to become tangled.

Case 2:

$d1 + d2 \leq 1.2 \times hi$

If $d1 + d2 \leq 1.2 \times$ E-Chain® inner height, a vertical separator or a horizontal shelf must be used to reduce the inner height, thereby preventing the entanglement of $d1$ and $d2$.

All-around clearance space in % for various cables/hoses

- Electrical round cables: 10%
- Electrical flat cables: 10%
- Pneumatics: 5-10%
- Hydraulics: 20%
- Media hoses: 15-20%

Various Applications

Vertical Hanging

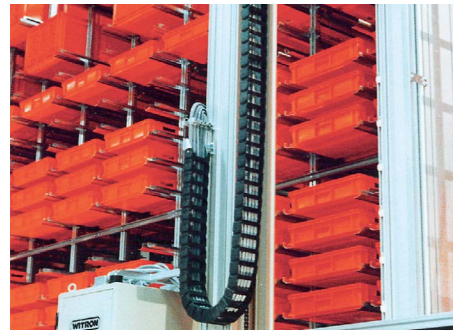

Vertical Standing



Side Mount

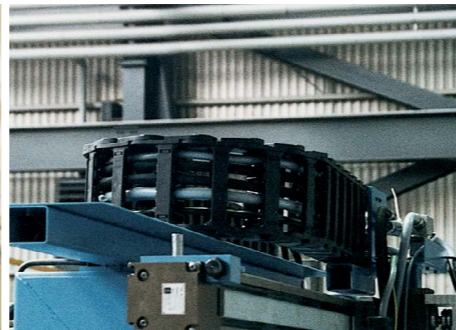

Zig Zag

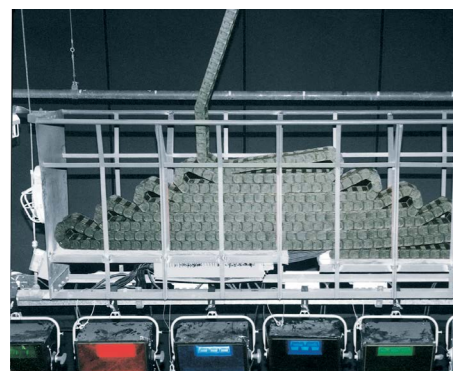

Twister



Rotary Motion

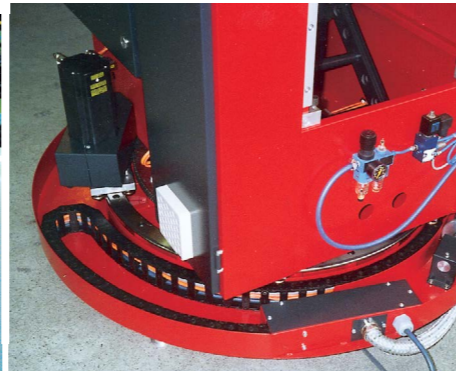

Principle behind the igus® Energy Chain® Gliding Applications

For long travels, the upper run of the igus® Energy Chain® rests on the lower run. The upper run glides partially on the lower run and partially at the same height on a glide bar. The diagrams below show this. For lateral guidance, a guide trough is necessary. If the stationary mounting bracket and the fixed end of the centre, the chain length is calculated as follows:

$$\text{chain length } L_k = S/2 + K + K_2$$

S = Length of travel

K = Add-on for bending radius (“K” is taken from the data tables of the individual igus® series)

K₂ = further add-on if the mounting bracket location is set lower (specified by igus®)



Example of lowered mounting height, in field operation



Mobile camera, live images, Olympic Games in Atlanta
S = 100 m
v = 10 m/s in push-pull operation

Depending on the technical data and the selected Energy Chain® the mounting point of the moving end of the Energy Chain® must be lowered on some units. In our system analysis for long travels, we give exact details for our specific application. The illustrations below show the function of a Energy Chain System® for gliding applications. The fixed end of the Energy Chain® is located in the centre of the travel distance.

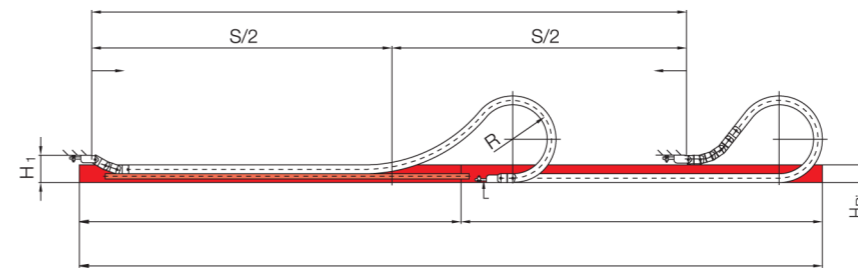

Gliding application up to 500m realised.

Guide Troughs

The Guide Trough is an important element in long travel applications. Usually, the height of the trough must be at least twice that of the chain link height. The sides must provide a chamfered opening. The trough inner width is the same as the chain outer width plus 5mm. Along the side of the trough, where the upper run cannot glide on the lower run, glide bars must be installed.

We recommend the use of polymer glide bars from igus®, they are optimally matched to the chain material and achieved the lowest values for friction, noise and wear. Guide troughs with and without glide bars can be obtained for almost all igus® Energy Chains®.

We will gladly assist you if you wish to make the troughs yourself.

Important: When assembling the trough parts, the following points must be given particular attention:

- Properly align all trough parts upon installation
- All screw heads should be flush with the trough
- Smooth levelled transition between the end of the chain and the glide bars
- Solid connection with the glide surface

These points must be observed when using assembly-friendly igus® guide troughs.



Various glide through systems are available

E2 micro | Series 06

2



Easy to assemble and to disassemble

- 1 High torsional rigidity
- 2 Very light weight - low price
- 3 Dirt-repellent exterior
- 4 Mounting bracket with integrated strain relief
- 5 Easy to fill configuration Series E06 Easy Chain®
- 6 Molded-in separator available Series 06.16.018.S1

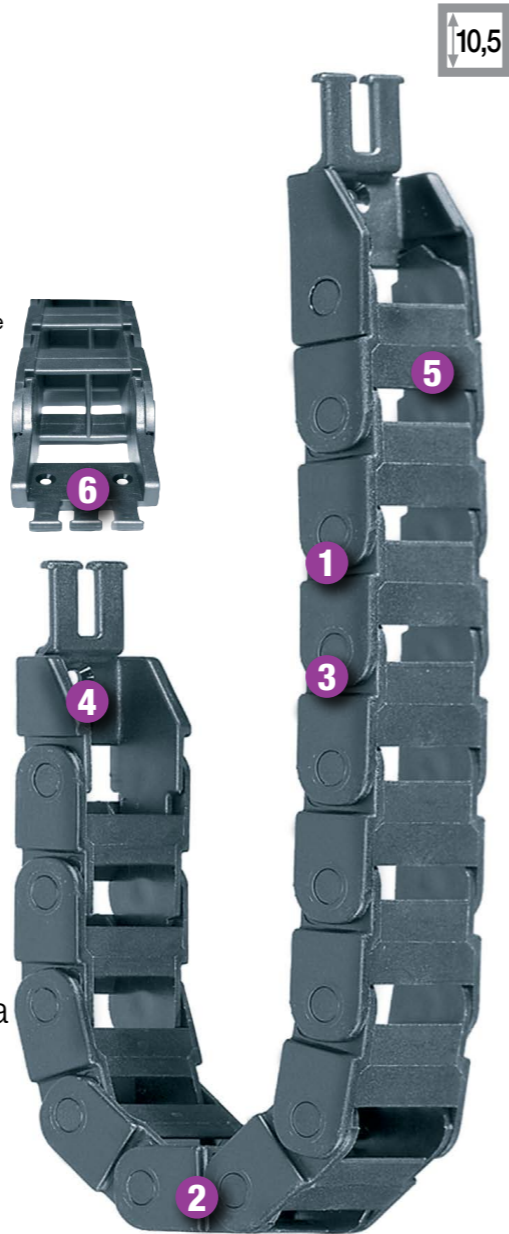

10,5

	When to use the Series 06: <ul style="list-style-type: none"> • High torsional rigidity • If price is an issue • If connection options are required (Quicksnap, Quickfix)
	When not to use it: <ul style="list-style-type: none"> • If snap-open links are required • If quick insertion of cables with preassembled connectors is required

E2 micro | Series 06 | Dimensions and Technical Data

Unsupported length
 FL_G = with straight upper run
 FL_B = with permitted sag

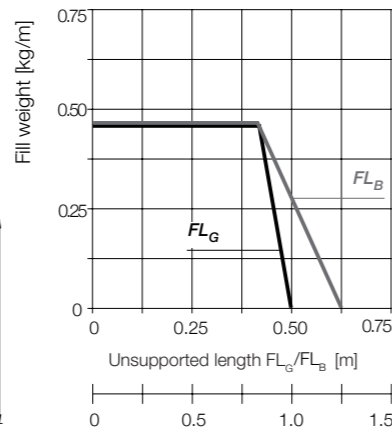
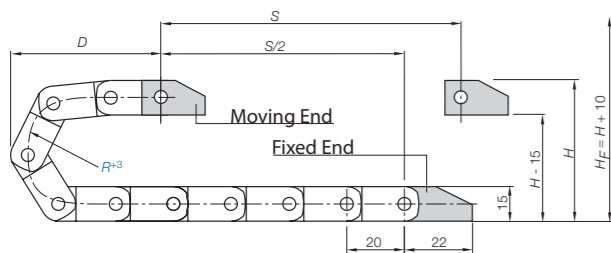
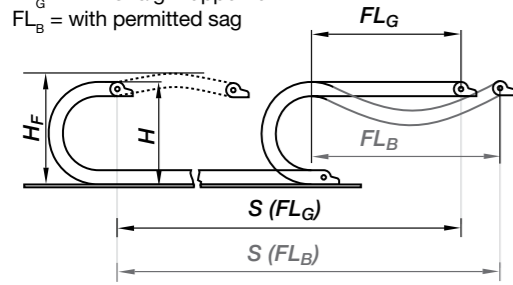

- S = Length of travel
- R = Bending radius
- H = Nominal clearance height
- HF = Required clearance height
- D = Overlength E-Chain® radius in final position
- $K = \pi \cdot R + \text{"safety"}$

Pitch = 20 mm/link Links/m = 50 (1.000 mm) Chain length = $S/2 + K$

	018	028	038
R	018	028	038
H	52	72	92
D	45	55	65
K	100	140	160

E2 micro | Series 06 | Product Range

2

Series 06 E-Chain® - non snap-open						
			R[mm] Bending Radii			
06.06.	.0	6	12,5	018	028	038
06.10.	.0	10	16,5	018	028	038
06.16.	.0	16	22,5	018	028	038
06.20.	.0	20	27,0	018	028	038
06.30.	.0	30	37,0	018	028	038
06.40.	.0	40	47,0	018	028	038
06.50.	.0	50	57,0	018	028	038
06.64.	.0	64	71,0	018	028	038

Supplement Part No. with required radius. Example: 06.10.028.0

E2 micro | Series 06 | Accessories | Mounting Brackets

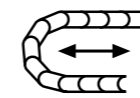

Polymer, one-piece

- One-piece mounting bracket
- Corrosion-resistant
- Available preassembled
- Inner and outer attachment possible
- Available with or without strain relief tiwrap plates

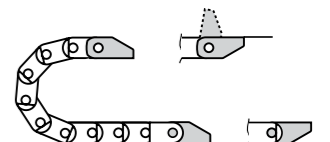

060...1(PZ)
Moving end

060...2(PZ)
Fixed end

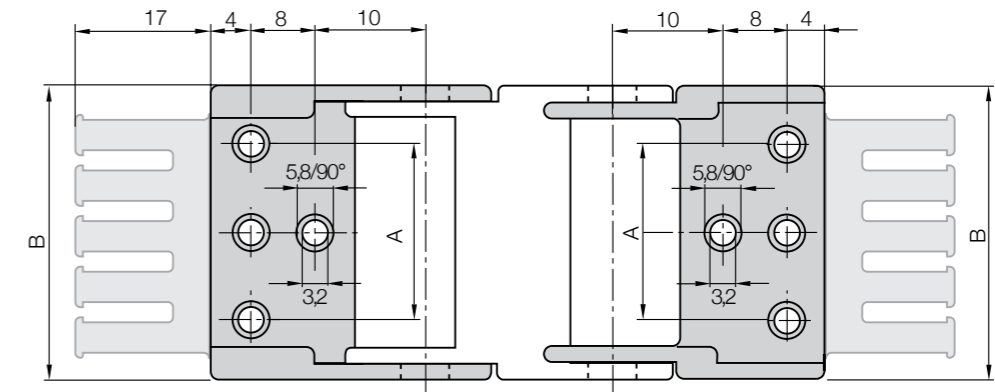

Order configuration and dimensions

E-Chain Part No.	Bracket Part No.	Number of teeth	Dim. A [mm]	Dim. B [mm]
06.06.	060.06. 12 PZ	1	-	12.5
06.10.	060.10. 12 PZ	1	-	16.5
06.16.	060.16. 12 PZ	2	-	22.5
06.20.	060.20. 12 PZ	2	-	27.0
06.30.	060.30. 12 PZ	3	22	37.0
06.40.	060.40. 12 PZ	4	32	47.0
06.50.	060.50. 12 PZ	5	42	57.0
06.64.	060.64. 12 PZ	6	56	71.0

New generation E2 micro | Series E2.10 • E2i.10 • E2C.10



The new generation of igus® small E-Chains®: lighter, more stable and easier to open.

Series E2.10 – Snap-open in the outer radius on both sides (Standard).

Series E2i.10 – Snap-open in the inner radius on both sides.

Series E2C.10 – Not to open E-Chain®

- Dual stop dog for up to 70% longer unsupported lengths and 50% heavier additional loads (compared to igus® identical types)
- Very smooth contours, cable friendly
- Mounting bracket with integrated strain relief option, quick flange for front facing assembly optional
- One-piece design, cost-effective
- Integrated “brake” for noise reduction

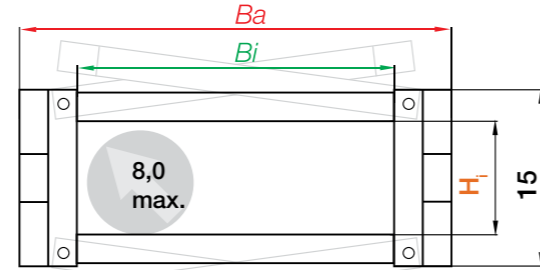
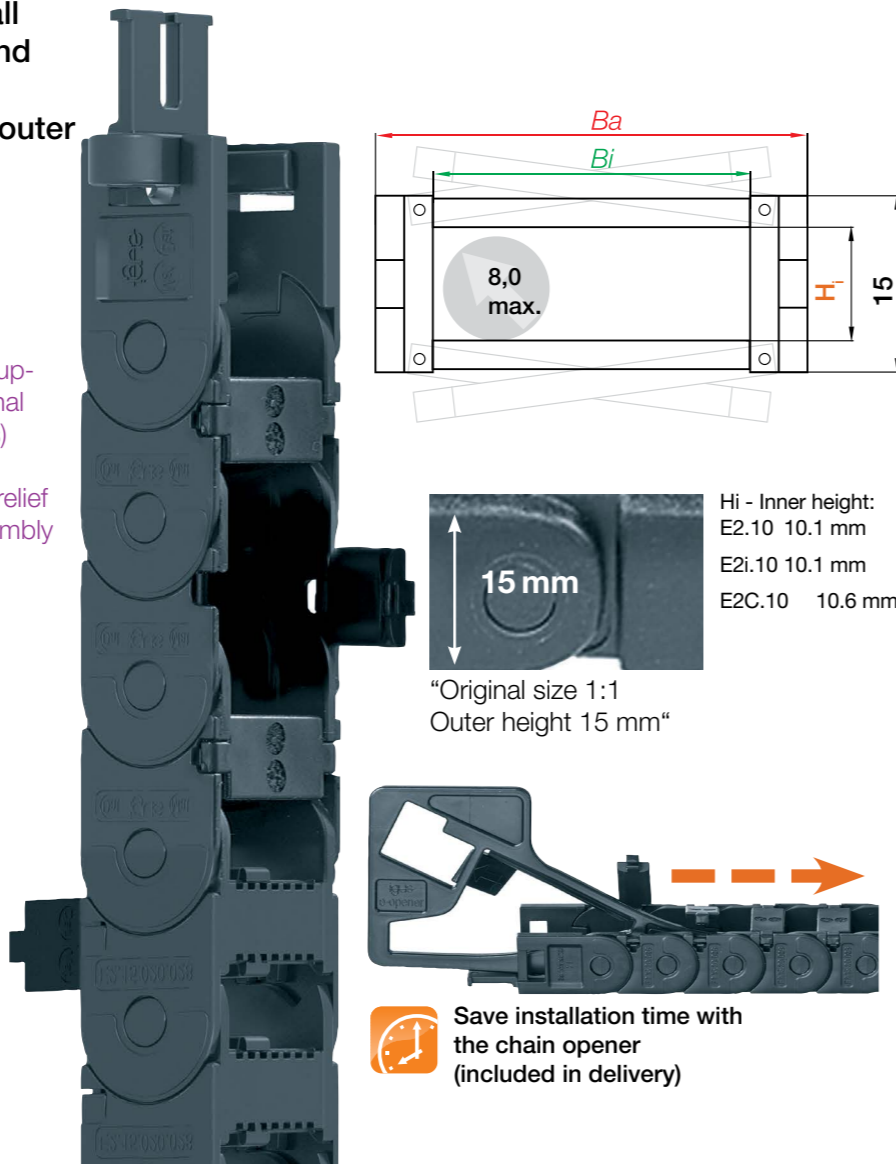

Hi - Inner height:
E2.10 10.1 mm
E2i.10 10.1 mm
E2C.10 10.6 mm

“Original size 1:1
Outer height 15 mm”

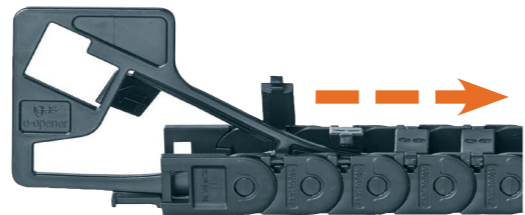

Save installation time with the chain opener (included in delivery)

Interior Separation



Slotted separator for E-Chains®
unassembled Part No. E2.10.5
assembled Part No. E2.10.5.1

Installation Dimensions

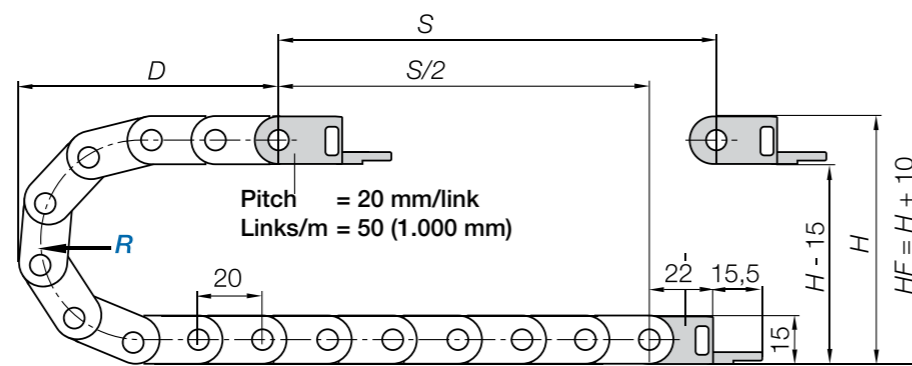
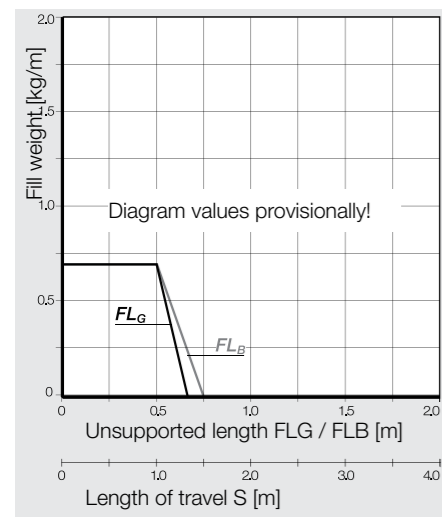

Pitch = 20 mm/link Links/M = 50 (1.000 mm) Chain length = S/2 + K

	018	028	038
R	51	71	91
H	56	66	76
K	100	130	160

E2 micro Series E2.10 Inner height: 10.1 - Snap-open on the outer radius

Part No	Bi[mm]	Ba[mm]	R[mm] Bending Radii	Weight (kg/m)	Pivoting Bracket Set	Locking Bracket Set
E2.10.06.	06	13.4	018 028 038	≈ 0.130	E2.100.06.34PZ	E2.100.06.12PZ
E2.10.10.	10	17.4	018 028 038	≈ 0.135	E2.100.10.34PZ	E2.100.10.12PZ
E2.10.16.	16	23.4	018 028 038	≈ 0.156	E2.100.16.34PZ	E2.100.16.12PZ
E2.10.20.	20	27.4	018 028 038	≈ 0.167	E2.100.20.34PZ	E2.100.20.12PZ
E2.10.30.	30	37.4	018 028 038	≈ 0.195	E2.100.30.34PZ	E2.100.30.12PZ
E2.10.40.	40	47.4	018 028 038	≈ 0.219	E2.100.40.34PZ	E2.100.40.12PZ
E2.10.50.	50	57.4	018 028 038	≈ 0.246	E2.100.50.34PZ	E2.100.50.12PZ

Supplement Part No. with required radius. Example: E2.10.06.018.0

Series E2i.10 Inner height: 10.1- Snap-open on the inner radius

Part No	Bi[mm]	Ba[mm]	R[mm] Bending Radii	Weight (kg/m)	Pivoting Bracket Set	Locking Bracket Set
E2i.10.06.	06	13.4	018 028 038	≈ 0.129	E2.100.06.34PZ	E2.100.06.12PZ
E2i.10.10.	10	17.4	018 028 038	≈ 0.139	E2.100.10.34PZ	E2.100.10.12PZ
E2i.10.16.	16	23.4	018 028 038	≈ 0.156	E2.100.16.34PZ	E2.100.16.12PZ
E2i.10.20.	20	27.4	018 028 038	≈ 0.167	E2.100.20.34PZ	E2.100.20.12PZ
E2i.10.30.	30	37.4	018 028 038	≈ 0.194	E2.100.30.34PZ	E2.100.30.12PZ
E2i.10.40.	40	47.4	018 028 038	≈ 0.219	E2.100.40.34PZ	E2.100.40.12PZ
E2i.10.50.	50	57.4	018 028 038	≈ 0.245	E2.100.50.34PZ	E2.100.50.12PZ

Supplement Part No. with required radius. Example: E2i.10.06.018.0

Series E2C.10 Inner height: 10.6 - Non snap open E-Chain®

Part No	Bi[mm]	Ba[mm]	R[mm] Bending Radii	Weight (kg/m)	Pivoting Bracket Set	Locking Bracket Set
E2C.10.06	06	13.4	018 028 038	≈ 0.138	E2.100.06.34PZ	E2.100.06.12PZ
E2C.10.10.	10	17.4	018 028 038	≈ 0.144	E2.100.10.34PZ	E2.100.10.12PZ
E2C.10.16.	16	23.4	018 028 038	≈ 0.164	E2.100.16.34PZ	E2.100.16.12PZ
E2C.10.20.	20	27.4	018 028 038	≈ 0.174	E2.100.20.34PZ	E2.100.20.12PZ
E2C.10.30.	30	37.4	018 028 038	≈ 0.200	E2.100.30.34PZ	E2.100.30.12PZ
E2C.10.40.	40	47.4	018 028 038	≈ 0.225	E2.100.40.34PZ	E2.100.40.12PZ
E2C.10.50.	50	57.4	018 028 038	≈ 0.251	E2.100.50.34PZ	E2.100.50.12PZ

Supplement Part No. with required radius. Example: E2C.10.06.018.0

Supplement Part No. with required radius. Example: E2.10.06.018.0

Mounting Brackets - Polymer, one-piece | Pivoting or Locking

Pivoting recommended for gliding and unsupported applications.

Locking recommended for vertical applications.

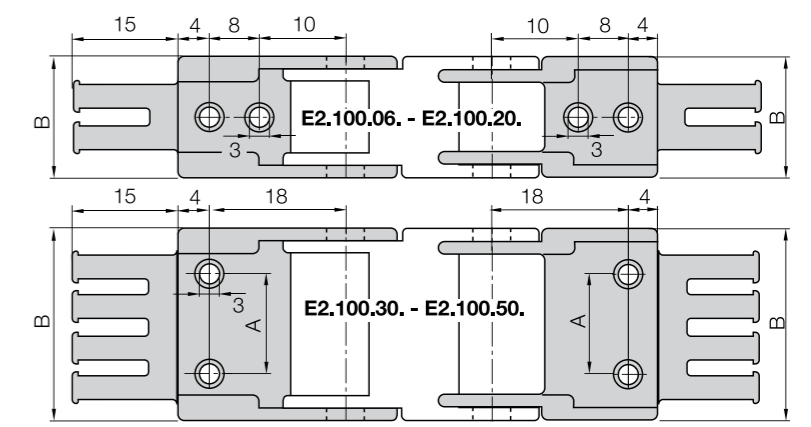
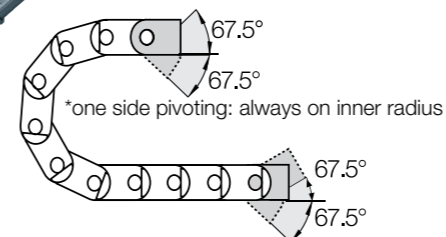

The required clearance height is HF = H + 10 mm (with 0,5 kg/m fill weight).

E2 mini | Series 10

Clean-Room
Cleanroom Class 1 (ISO class 3)
Tested by the Dryden Engineering Company, California

2

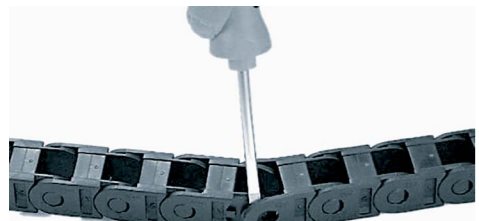

Easy to assemble and to disassemble

- 1 Large pins and double stop dog for superior life and long unsupported length
- 2 Mounting bracket with integrated strain relief
- 3 Dirt-repellent exterior
- 4 Interior separation available
- 5 One piece each link
- 6 Unopenable configuration
- 7 Molded-in separator available Series 10.050.075.S

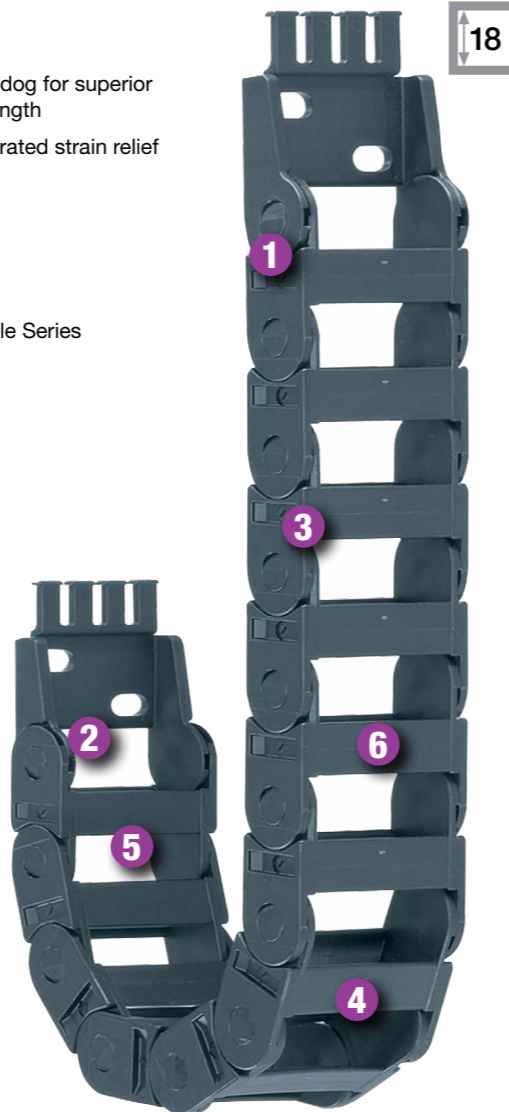
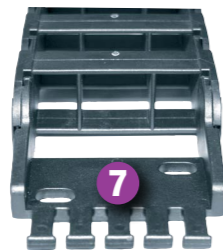

18

	<p>When to use the Series 10:</p> <ul style="list-style-type: none"> • If opening is not necessary • If many connection options are required (Quicksnap, Quickfix) • If a small but very stable chain is required
	<p>When not to use it:</p> <ul style="list-style-type: none"> • If opening of the links is necessary • If quick insertion of cables with preassembled connectors is required

E2 mini | Series 10 | Dimensions and Technical Data

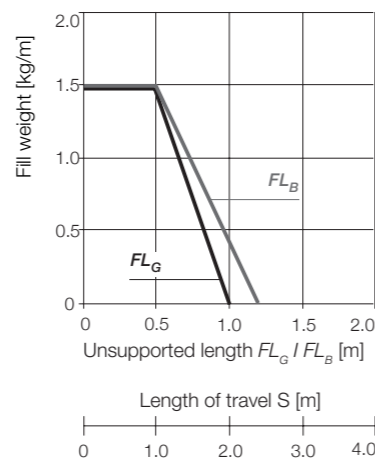
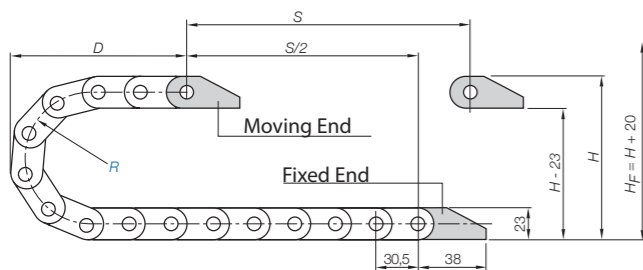
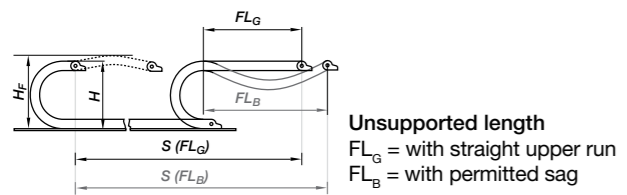

- S = Length of travel
- R = Bending radius
- H = Nominal clearance height
- HF = Required clearance height
- D = Over length E-Chain radius in final position
- $K = \pi \cdot R + \text{"safety"}$

Pitch = 30.5 mm/link Links/m = 33 (1.006,5 mm) Chain length = $S/2 + K$

R	028	038	048	075	100	110	125	145	180
H	80	100	120	175	225	245	275	315	385
D	70	80	90	120	145	155	170	190	225
K	150	185	215	300	375	410	455	520	630

E2 mini | Series 10 | Product Range

2

Series 10 E-Chain® - non snap-open

Part No	Bi[mm]	Ba[mm]	R[mm] Bending Radii									
			028	038	048	075	100	110	125	145	180	
10.015.	.0	15	29	028	038	048	075	100	110	125	145	180
10.025.	.0	25	36	028	038	048	075	100	110	125	145	180
10.038.	.0	38	49	028	038	048	075	100	110	125	145	180
10.050.	.0	50	61	028	038	048	075	100	110	125	145	180
10.5.	.0	63	76	028	038	048	075	100	110	125	145	180
10.6.	.0	80	94	028	038	048	075	100	110	125	145	180
10.7.	.0	100	113	028	038	048	075	100	110	125	145	180

Supplement Part No. with required radius. Example: 10.025. 038 .0

E2 mini | Series 10 | Accessories | Mounting Brackets



Pivoting

- Recommended for unsupported and gliding applications
- Well suited for tight installation conditions
- Strain relief with detachable tie wrap plates
- Variable traverse angle for flexible assembly

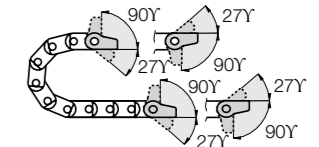

Locking

- For vertical hanging/standing applications
- At very high speed and/or acceleration
- If space is limited for height (the HF measurement)

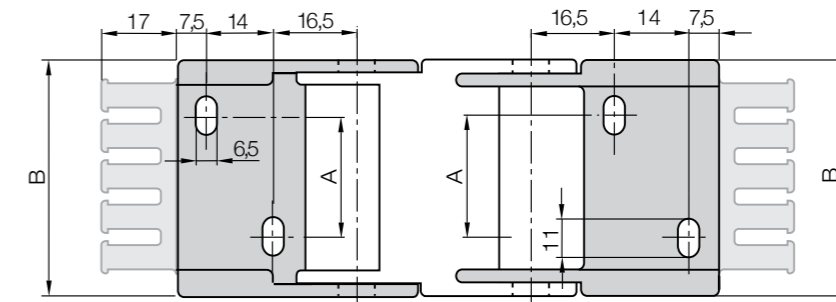
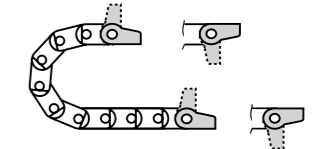

Order configuration and dimensions

E-Chain Part No.	Bracket Part No.	Dim. A [mm]	Dim. B [mm]
10.015.	1015. [] PZ	-	25.5
10.025.	1025. [] PZ	10	35.5
10.038.	1038. [] PZ	23	48.5
10.050.	1050. [] PZ	35	60.5
10.5.	105. [] PZ	48	75.0
10.6.	106. [] PZ	65	92.0
10.7.	107. [] PZ	85	112.0

Please add the Part No. with the requested index - 34 for the pivoting configuration e.g. 1025. 34 PZ or 12 for the locking configuration e.g. 1025. 12 .PZ

Easy Chain® | Series E08-Z08

	UL94-V2 classifications
	Torsional motion possible

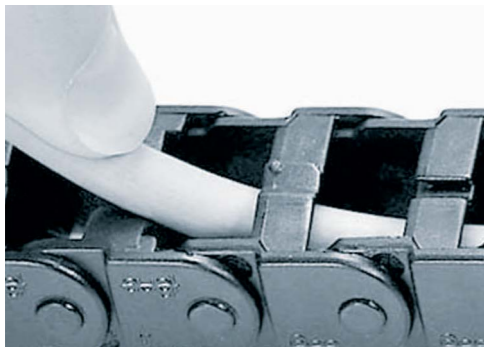

Just push in cable by hand - and it's ready

- 1 Very easy to fill - ideal for harnessed cable assemblies
- 2 Small pitch for low-noise, smooth operation
- 3 Limited torsion tolerance
- 4 Light Weight
- 5 The patented push-button principle holds the links together
- 6 Cable-friendly interior
- 7 "E" Series features split crossbar along the outer radius
- 8 "Z" Series features split crossbar along the inner radius
- 9 Integrated strain relief option

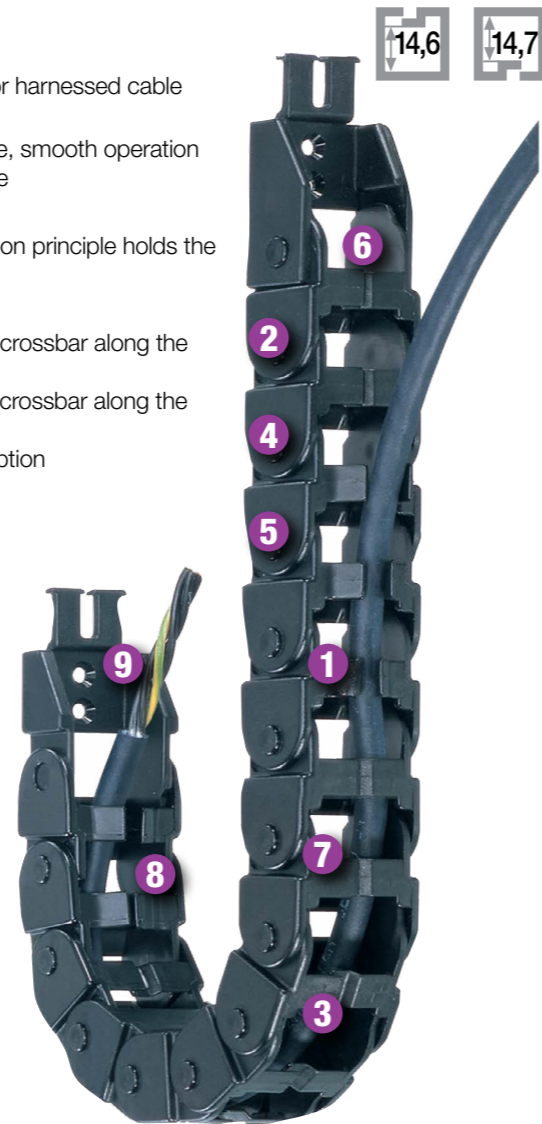

	When to use the Series E08/Z08: <ul style="list-style-type: none"> • If filling is required without opening and closing lids • If price is an issue • If quiet operation is required
	When not to use it: <ul style="list-style-type: none"> • For applications with very high loads and long unsupported travel lengths

Easy Chain® | Series E08-Z08 | Dimensions and Technical Data

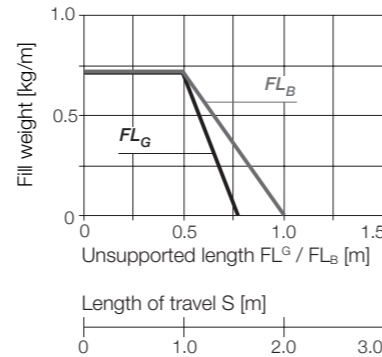
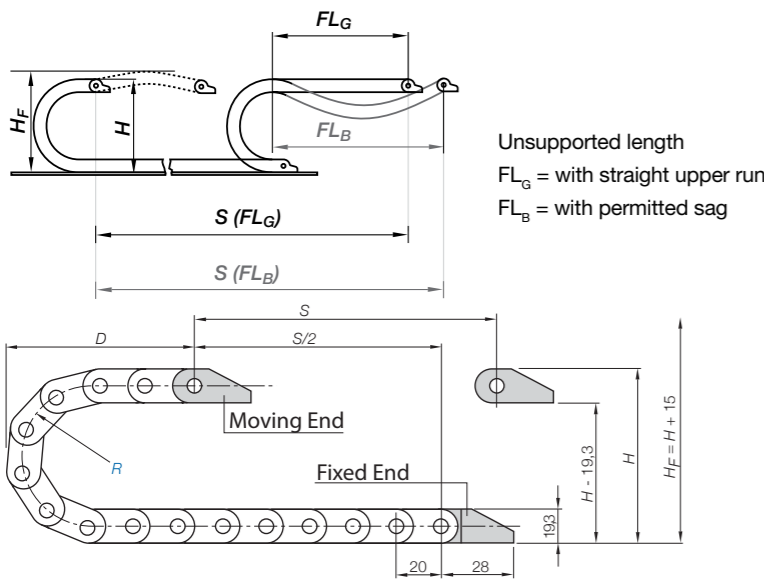

- S = Length of travel
- R = Bending radius
- H = Nominal clearance height
- HF = Required clearance height
- D = Overlength E-Chain® radius in final position
- $K = \pi \cdot R + \text{"safety"}$

Pitch = 20 mm/link Links/m = 50 (1.000 mm) Chain length = S/2 + K

R	028	038	048
H	76	96	116
D	60	70	80
K	130	160	190

Easy Chain® | Series E08-Z08 | Product Range

Series E08 - split crossbar along the outer radius

Part No.	Bi[mm]	Ba[mm]	R[mm] Bending radii		
E08.10.	10	18,2	028	038	048
E08.16.	16	24,2	028	038	048
E08.20.	20	28,2	028	038	048
E08.30.	30	38,2	028	038	048
E08.40.	40	48,2	028	038	048
E08.50.	50	58,2	028	038	048

Supplement Part No. with required radius. Example: E08.30.038.0

Series Z08 - split crossbar along the inner radius

Part No.	Bi[mm]	Ba[mm]	R[mm] Bending radii		
Z08.10.	10	18,2	028	038	048
Z08.16.	16	24,2	028	038	048
Z08.20.	20	28,2	028	038	048
Z08.30.	30	38,2	028	038	048
Z08.40.	40	48,2	028	038	048
Z08.50.	50	58,2	028	038	048

Supplement Part No. with required radius. Example: Z08.30.038.0

Easy Chain® | Series E08-Z08 | Accessories | Mounting Brackets

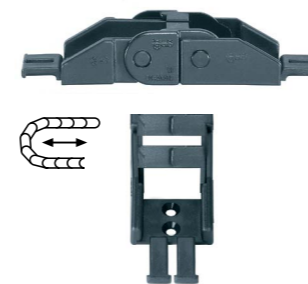

- Polymer, one-piece**
- One-piece mounting bracket
 - Corrosion-resistant
 - Available preassembled
 - Inner and outer attachment possible
 - Available with integrated strain relief tiewrap plates

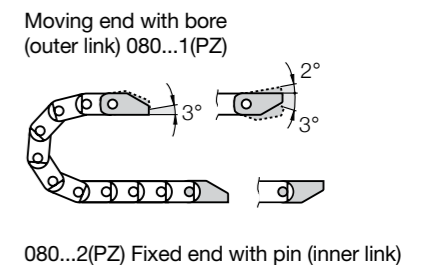

Order configuration and dimensions

E-Chain Part No	Bracket Part No: - with tiewrap plate	Number of teeth	Dim. A [mm]	Dim. B [mm]
E08-Z08.10.	080.10.12.PZ	1	-	18,2
E08-Z08.16.	080.16.12.PZ	2	-	24,2
E08-Z08.20.	080.20.12.PZ	2	-	28,2
E08-Z08.30.	080.30.12.PZ	3	22	38,2
E08-Z08.40.	080.40.12.PZ	4	32	48,2
E08-Z08.50.	080.50.12.PZ	5	42	58,2

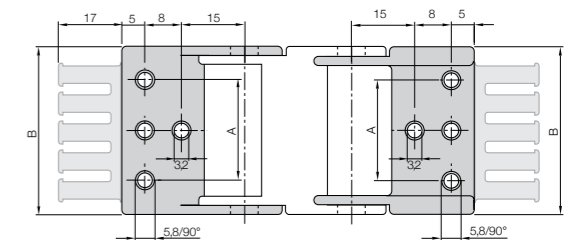

E2 micro | Series E2-15 | Product range

Next generation, stable, low noise, fast opening

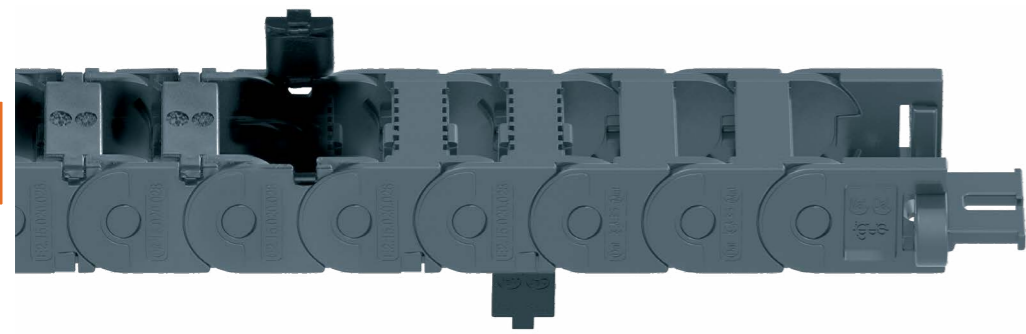
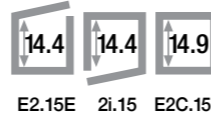

Series E2.15 | **Snap-open along** outer radius from both sides | **Standard**
 Series E2i.15 | **Snap-open along** inner radius from both sides
 Series E2C.15 | **One-piece, non snap-open e-chain®**

Order configuration and dimensions										
Snap open along outer radius	Snap open along inner radius	One piece non snap open	Width Bi [mm]	Width Ba [mm]	Radius R [mm]			E2.15 [kg/m]	E2i.15 [kg/m]	E2C.15 [kg/m]
E2.15.10.R.0	E2i.15.10.R.0	E2C.15.10.R.0	10	17.8	028	038	048	≈ 0.18	≈ 0.18	≈ 0.18
E2.15.13.R.0	E2i.15.13.R.0	E2C.15.13.R.0	13	20.8	028	038	048	≈ 0.19	≈ 0.19	≈ 0.19
E2.15.16.R.0	E2i.15.16.R.0	E2C.15.16.R.0	16	23.8	028	038	048	≈ 0.20	≈ 0.20	≈ 0.20
E2.15.20.R.0	E2i.15.20.R.0	E2C.15.20.R.0	20	27.8	028	038	048	≈ 0.21	≈ 0.21	≈ 0.21
E2.15.30.R.0	E2i.15.30.R.0	E2C.15.30.R.0	30	37.8	028	038	048	≈ 0.24	≈ 0.24	≈ 0.24
E2.15.40.R.0	E2i.15.40.R.0	E2C.15.40.R.0	40	47.8	028	038	048	075	≈ 0.26	≈ 0.26
E2.15.50.R.0	E2i.15.50.R.0	E2C.15.50.R.0	50	57.8	028	038	048	≈ 0.29	≈ 0.29	≈ 0.29

Supplement Part No. with required radius (R). Example: E2.15.20.038.0

Radius (R). 075 only for series E2C.15.40

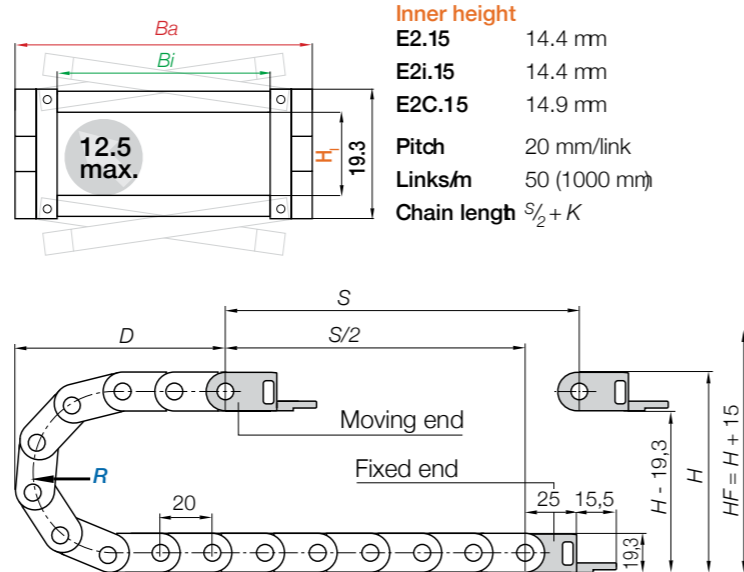
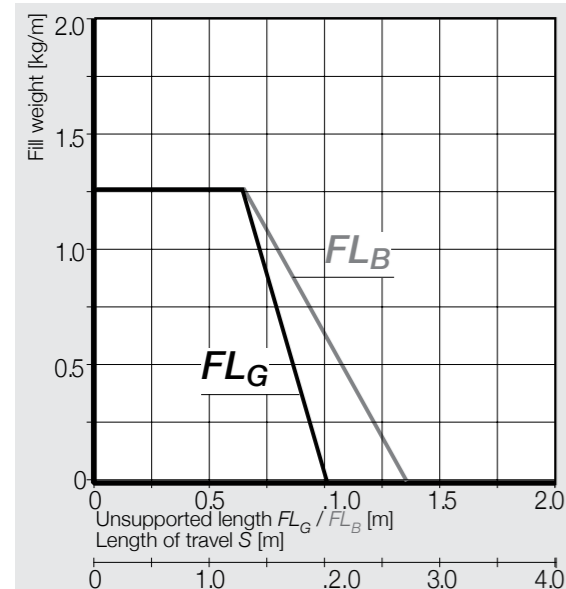

Inner height
 E2.15 14.4 mm
 E2i.15 14.4 mm
 E2C.15 14.9 mm
Pitch 20 mm/link
Links/m 50 (1000 mm)
Chain length $S/2 + K$

The required clearance height: $H_f + H + 15\text{mm}$ (with 0.3 kg/m fill weight)

Pitch = 20 mm/link **Links/m** = 50 (1.000 mm) **Chain length** = $S/2 + K$

R	028	038	048	075
H	75	95	115	169
D	68	78	88	115
K	130	160	195	280

E2 micro | Series E2-15 | Accessories

Mounting brackets, polymer one-piece | one side* or two side pivoting | locking

Moving end	two side pivoting	Fixed end
E2.150..3PZ	one side* pivoting	E2.150...4PZ
E2.150..5PZ	locking	E2.150...6PZ
E2.150..1PZ		E2.150...2PZ

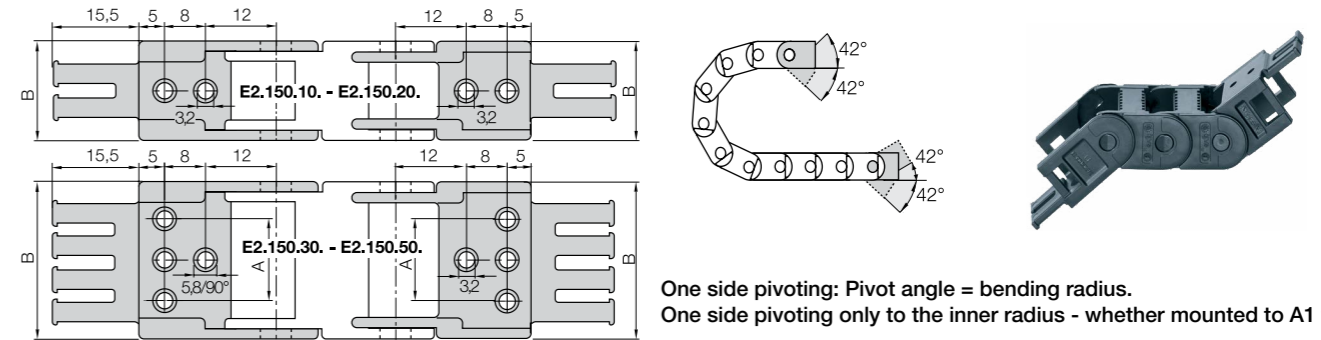

One side pivoting: Pivot angle = bending radius.
 One side pivoting only to the inner radius - whether mounted to A1 to A4

Width Index	Part No. full set with tiewrap plates two side pivoting	Part No. full set with tiewrap plates one side* pivoting	Part No. full set with tiewrap plates locking	Dim. A [mm]	Dim. B [mm]	Number of teeth
10. ▶	E2.150.10.34PZ	E2.150.10.56PZ	E2.150.10.12PZ	-	17.8	1
13. ▶	E2.150.13.34PZ	E2.150.13.56PZ	E2.150.13.12PZ	-	20.8	1
16. ▶	E2.150.16.34PZ	E2.150.16.56PZ	E2.150.16.12PZ	-	23.8	2
20. ▶	E2.150.20.34PZ	E2.150.20.56PZ	E2.150.20.12PZ	-	27.8	2
30. ▶	E2.150.30.34PZ	E2.150.30.56PZ	E2.150.30.12PZ	22	37.8	3
40. ▶	E2.150.40.34PZ	E2.150.40.56PZ	E2.150.40.12PZ	32	47.8	4
50. ▶	E2.150.50.34PZ	E2.150.50.56PZ	E2.150.50.12PZ	42	57.8	5

Interior separation | New generation

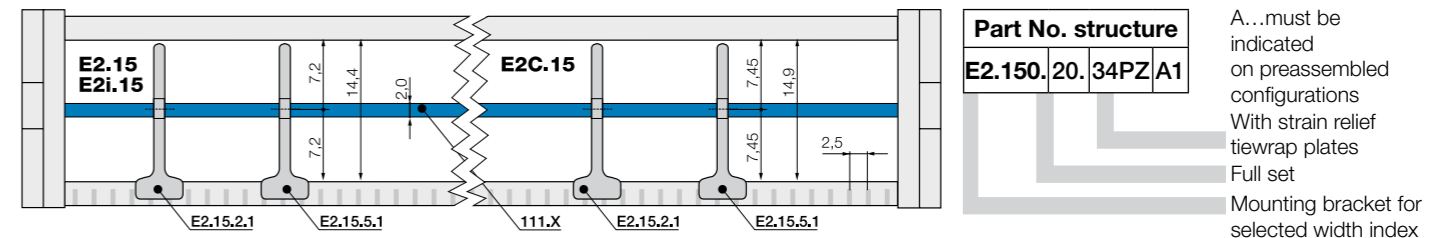

Note E2C.15: For one-piece, non snap-open please assemble the interior separation before fitting the e-chain®!
 As standard separators are assembled every 2nd e-chain® link.

		Standard separator, for e-chains®	Standard - for any application Is used when vertical separation is required. Due to its slot, it allows basic vertical/horizontal shelving arrangements. No snap-in option, freely movable.
		Unassembled	E215.2
		Assembled	E215.2.1
		Notch separator for notch crossbar	Locks safely onto in 2,5 mm increments For exact positioning in e-chains®. Recommended for side mounted applications. Abrasion-optimised, cable-friendly design of the separator.
		Unassembled	E2.15.5
		Assembled	E2.15.5.1
		Full-width shelf e-chains®	Full-width shelf 110.X This option makes sense in applications with many thin cables with similar diameters. For a consequent subdivision.
		Unassembled	110.X
		Assembled	111.X

Full-width shelves 110.X

Width X (mm)	Unassembled	Assembled	Width X (mm)	Unassembled	Assembled	Width X (mm)	Unassembled	Assembled
010	110.10	111.10	020	110.20	111.20	050	110.50	111.50
013	110.13	111.13	030	110.30	111.30			
016	110.16	111.16	040	110.40	111.40			

E2/000 | e-chains® | Series 1400 • 1500

IPA Qualification Certificate Air Cleanless Class ISO Class 3 (at v = 2 m/s) upon request

ESD classification: Electrically conductive ESD/ATEX version upon request

UL94 V2 classifications upon request

- 1 Universal: Many mounting options with or without strain relief
- 2 Easy to assemble: Opening system from left or right
- 3 High stability: Large pin "snap fastener" with high clamping force
- 4 Long lifetime: Lateral gliding surfaces
- 5 High unsupported lengths: Due to a double, square stop dog
- 6 Variations: e-chain® or e-tube, openable at the inner or outer radius

Typical industries and applications

- Material handling
- Construction machinery
- Woodworking machines
- Glass machines
- Plastic machines
- Long travel applications
- Semicon, Theatre, entertainment and amusement parks
- Vehicles
- General machinery

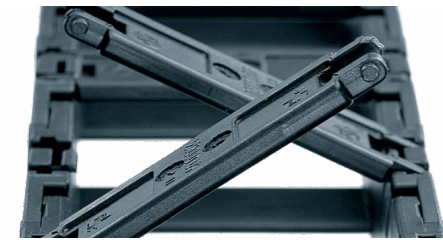
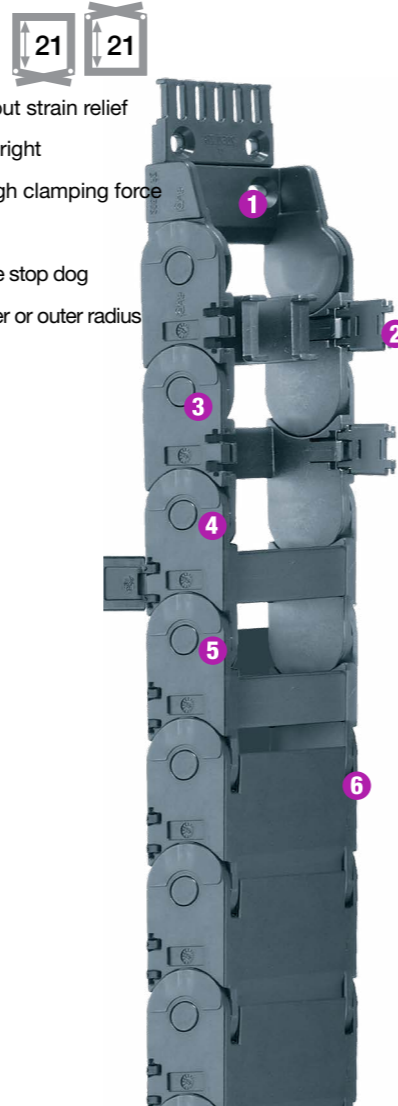

Snap open mechanism left or right.

	<p>When to use the Series 15:</p> <ul style="list-style-type: none"> • If snap-open accessibility along inner or outer radius is required • If integrated strain relief is required at the connection point • If "Half" E-Tube is required (Series 1450) • If fully enclosed E-Tube is required (Series 1480) • If long service life is required • If easy installation is required • Standard product with many accessories
	<p>When not to use it:</p> <ul style="list-style-type: none"> • If the application is very simple

E2/000 | e-chains® | Series 1400 • 1500 | Dimensions and Technical Data

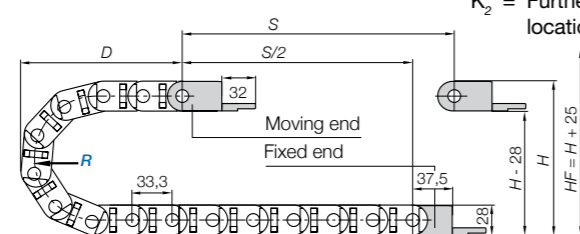
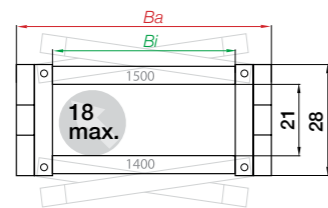
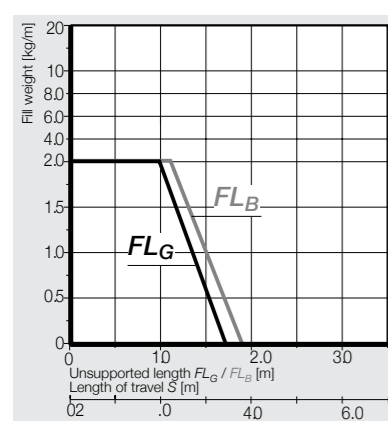

S = Length of travel
 R = Bending radius
 H = Nominal clearance height
 H_F = Required clearance height
 H_{ri} = Trough inner height
 D = Over length, E Chain radius final position
 K = π • R + "safety"
 D₂ = Over length for long travels
 K₂ = Further add-on if the mounting bracket location is set lower

Pitch = 33,3 mm/link Links/m = 30 (1000 mm) Chain length = S/2 + K

R	035	038	048	075	100	125	145	180
H	98	104	124	178	228	278	318	388
D	99	102	112	139	164	189	209	244
K	180	190	220	305	385	460	525	635

Series 1500 - E-Chain® - snap-open along outer radius - Standard

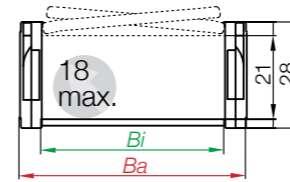

Part No	Bi[mm]	Ba[mm]	R[mm] Bending Radii								Weight[kg/m]	
1500.015.	.0	15	28.5	035	038	048	075	100	125	145	180	≈ 0.46
1500.020.	.0	20	33.5	035	038	048	075	100	125	145	180	≈ 0.48
1500.025.	.0	25	38.5	035	038	048	075	100	125	145	180	≈ 0.49
1500.038.	.0	38	51.5	035	038	048	075	100	125	145	180	≈ 0.54
1500.050.	.0	50	63.5	035	038	048	075	100	125	145	180	≈ 0.58
1500.068.	.0	68	81.5	035	038	048	075	100	125	145	180	≈ 0.64
1500.080.	.0	80	93.5	035	038	048	075	100	125	145	180	≈ 0.67
1500.100.	.0	100	113.5	035	038	048	075	100	125	145	180	≈ 0.74
1500.125.	.0	125	138.5	035	038	048	075	100	125	145	180	≈ 0.83

Supplement Part No. with required radius. Example: 1400.015.035.0

Part No. structure
 1500|015|.035|. 0

Colour Black
 Bending Radius
 Width
 Series

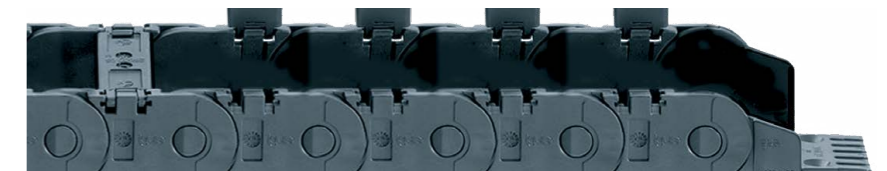

Series 1400 - E-Chain® - snap-open along inner radius

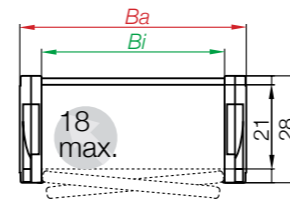

Part No	Bi[mm]	Ba[mm]	R[mm] Bending Radii								Weight[kg/m]	
1400.015.	.0	15	28.5	035	038	048	075	100	125	145	180	≈ 0.46
1400.020.	.0	20	33.5	035	038	048	075	100	125	145	180	≈ 0.48
1400.025.	.0	25	38.5	035	038	048	075	100	125	145	180	≈ 0.49
1400.038.	.0	38	51.5	035	038	048	075	100	125	145	180	≈ 0.54
1400.050.	.0	50	63.5	035	038	048	075	100	125	145	180	≈ 0.58
1400.068.	.0	68	81.5	035	038	048	075	100	125	145	180	≈ 0.64
1400.080.	.0	80	93.5	035	038	048	075	100	125	145	180	≈ 0.67
1400.100.	.0	100	113.5	035	038	048	075	100	125	145	180	≈ 0.74
1400.125.	.0	125	138.5	035	038	048	075	100	125	145	180	≈ 0.83

Supplement Part No. with required radius. Example: 1400.015.035.0

Part No. structure
 1400|015|.035|. 0

Colour Black
 Bending Radius
 Width
 Series

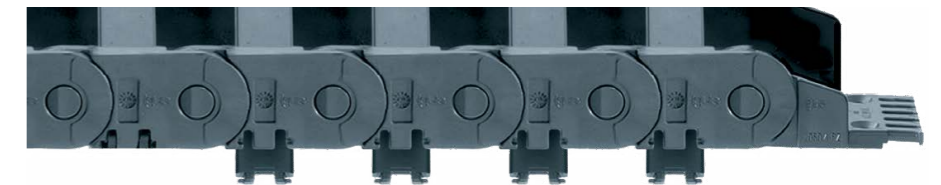

Gliding applications Long Travels from 10m to max. 75m. NOTE: Long Travels should use series 1500

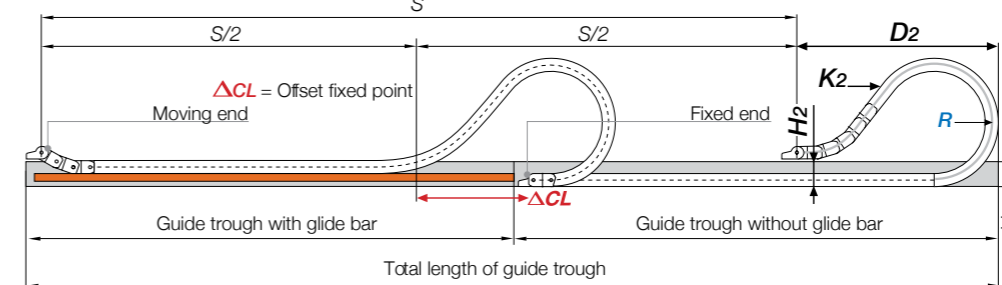

HRI = Trough inner height
 K = Length of chain in bend for Long Travels
 D2 = Over length for long travels
 K2 = Length of chain in bend for Long Travels

R	035	038	048	075	100	125	145	180
H ₂	70	76	96	150	100	100	100	100
D ₂ ⁺²⁵	99	102	112	139	340	495	540	690
K ₂	180	190	220	305	600	800	940	1170
ΔCL	-	-	-	-	179	305	340	445

E2.1 | **E2i.26·E2.26** | Product range the strong all-rounder, easy to open

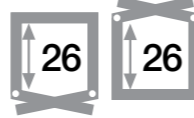

This product replaces the 2400/2500 series



2

e-chains® | **Series E2i.26** | Crossbars openable along the inner radius, from both sides

e-chains® | **Series E2.26** | Crossbars openable along the outer radius, from both sides

Part No. e-chains® openable along inner radius		Part No. e-chains® openable along outer radius		Bi	Ba	R	R										E2i.26	E2.26	
				Bi[mm]	Ba[mm]	R[mm]	Bending Radii [mm]												
E2i.26.	025	.R.0	E2.26.	025	.R.0	25	42	048	055	075	100	125	150	175	200	225	250	≈ 0.77	≈ 0.77
E2i.26.	038	.R.0	E2.26.	038	.R.0	38	55	048	055	075	100	125	150	175	200	225	250	≈ 0.84	≈ 0.84
E2i.26.	057	.R.0	E2.26.	057	.R.0	57	74	048	055	075	100	125	150	175	200	225	250	≈ 0.92	≈ 0.92
E2i.26.	077	.R.0	E2.26.	077	.R.0	77	94	048	055	075	100	125	150	175	200	225	250	≈ 0.99	≈ 0.99
E2i.26.	089	.R.0	E2.26.	089	.R.0	89	106	048	055	075	100	125	150	175	200	225	250	≈ 1.03	≈ 1.03
E2i.26.	103	.R.0	E2.26.	103	.R.0	103	120	048	055	075	100	125	150	175	200	225	250	≈ 1.10	≈ 1.10
E2i.26.	125	.R.0*	E2.26.	125	.R.0*	125	142	048	055	075	100	125	150	175	200	225	250	≈ 1.19	≈ 1.19

*Width available upon request. Please consult igus® for delivery time.

Complete Part No. with required radius (R). Example: **E2.26.038.048.0**

Aluminium support tray

- Corrosion-resistant and seawater-resistant aluminium rails with adjustable width
- Noise-reducing glide strip integrated as standard
- Easy installation and connection of the e-chain®
- Open design - dirt and debris fall through

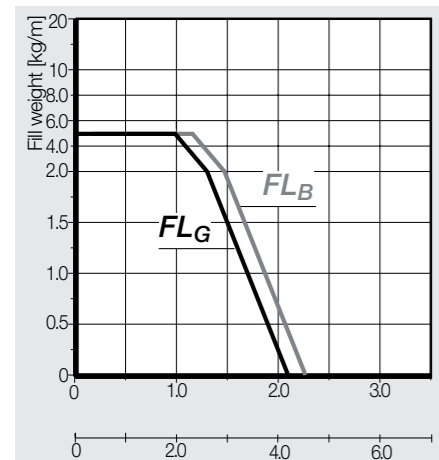

Unsupported length FL_G / FL_B [m] Travel S [m]

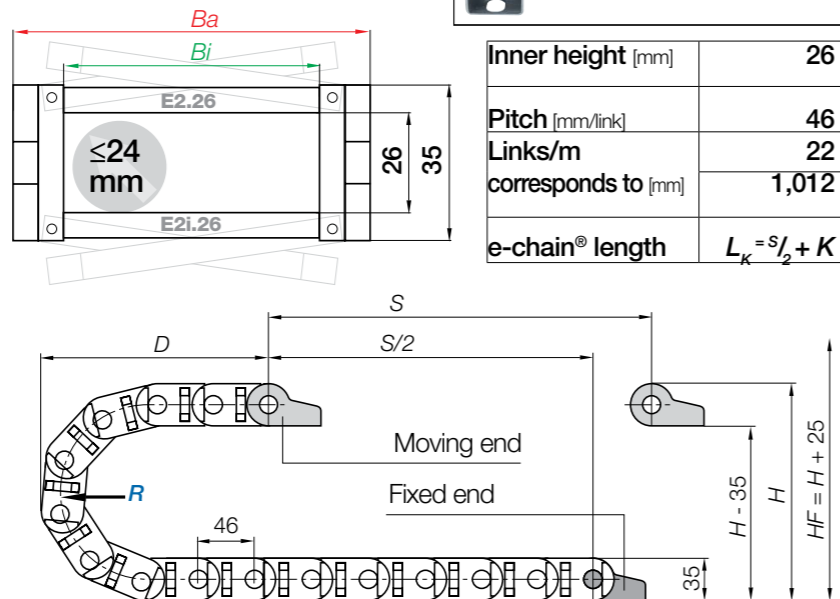

E2.1 | **E2i.26·E2.26** | Installation dimensions unsupported applications | Short travels

R	048	055	075	100	125	150	175	200	225	250
H	131	145	185	235	285	335	385	435	485	535
D	135	142	162	187	212	237	262	287	312	337
K	245	265	330	410	485	565	645	725	800	880

Gliding applications | For travel lengths from 10m to max. 100m

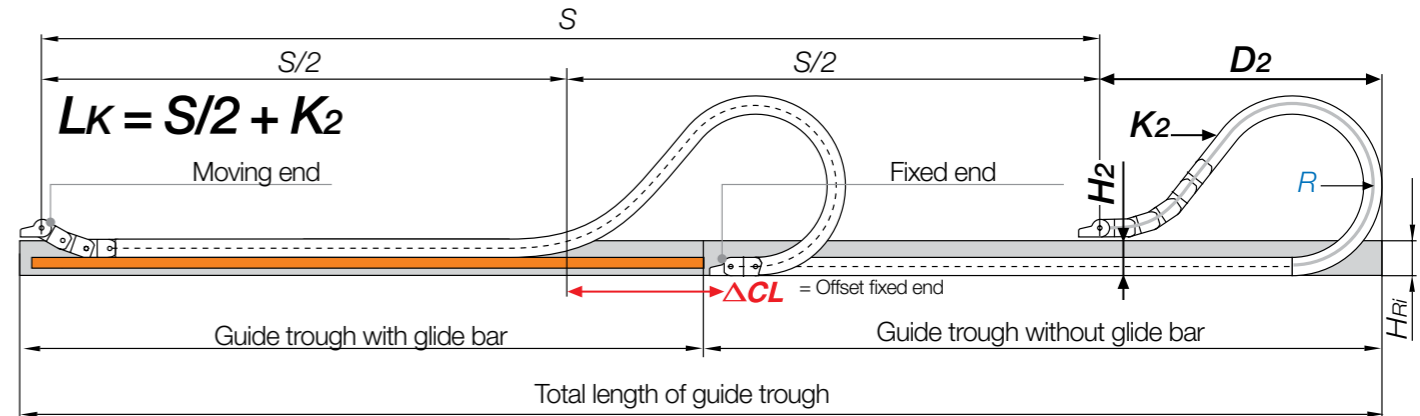

Note: Before using series E2i.26 on long travels please consult igus®.

For long travels, igus® recommends series E2.26 openable along the outer radius.

In case of travels between 4 and 10m we recommend an e-chain® with a longer unsupported length.

R	048	055	075	100	125	150	175	200	225	250
H ₂	131	110	150	100	100	100	100	100	100	100
D ₂ ⁺²⁵	135	145	162	380	440	590	755	950	1040	1130
K ₂	245	265	330	644	736	1012	1242	1472	1610	1794
ΔACL				204	244	364	504	674	754	804

E2.1 | E2i.26-E2.26 | Accessories Mounting brackets, polymer | Pivoting | Locking

This product replaces the 2400/2500 series

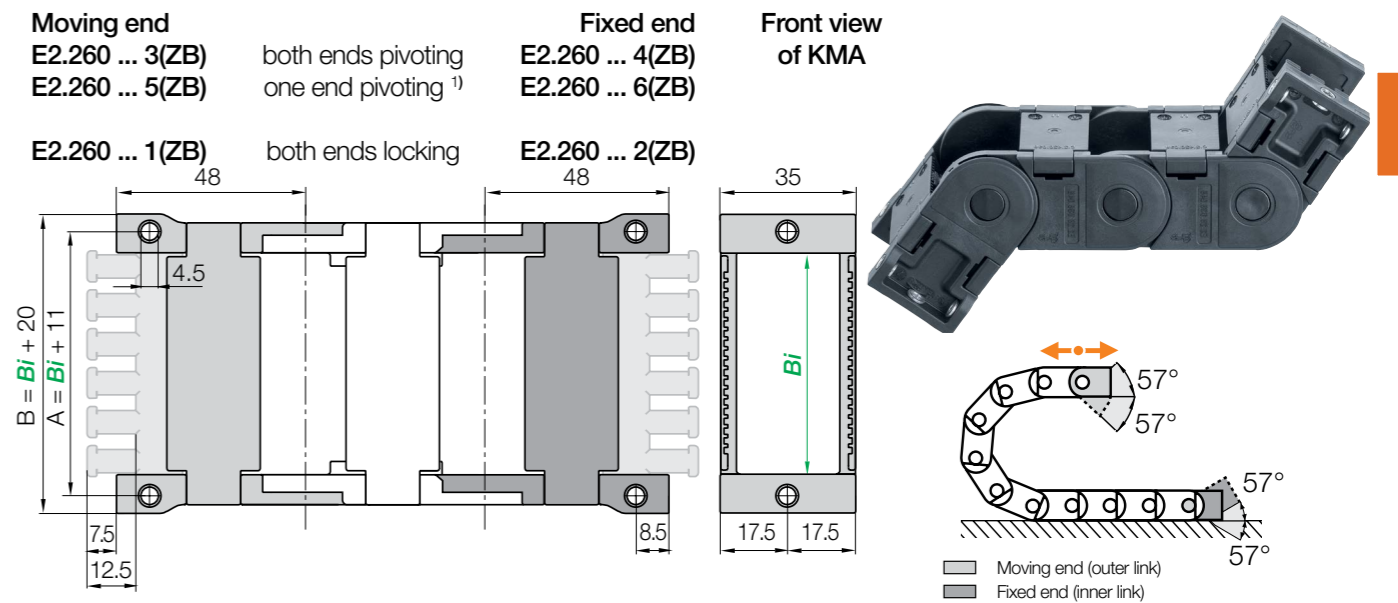
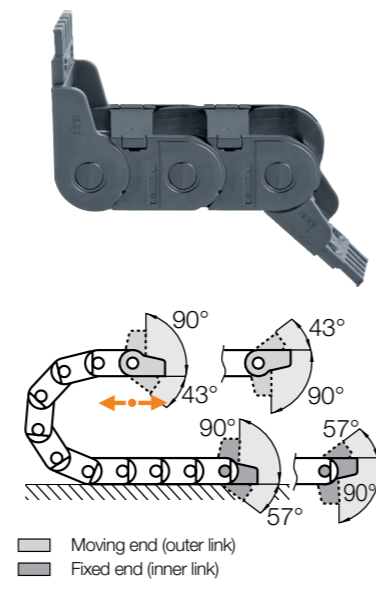
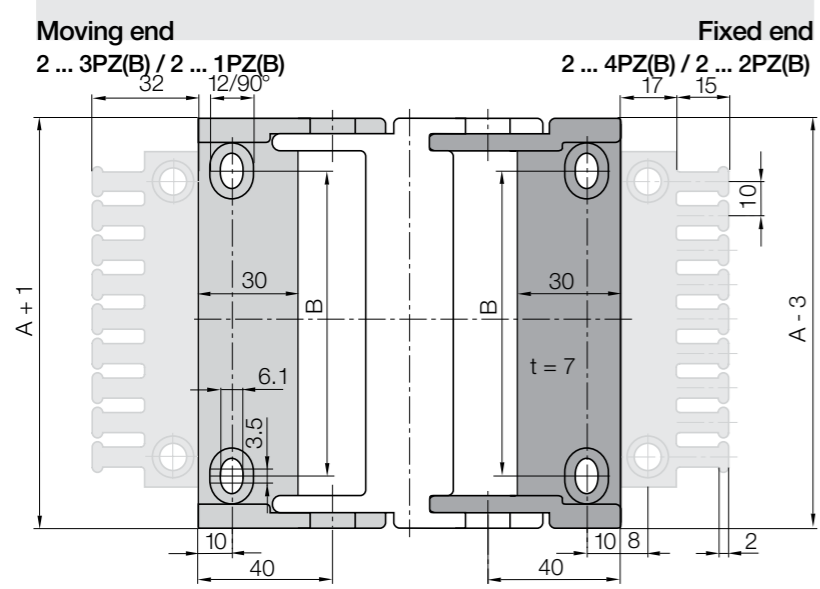

2

2



Polymer pivoting | **Recommended for** unsupported and gliding applications
 Polymer locking | **Recommended for** vertical hanging and standing applications

KMA pivoting | **Recommended for** unsupported and gliding applications
 KMA locking | **Recommended for** vertical hanging and standing applications

Width Index	Part No. full set pivoting		Part No. full set locking		A [mm]	B [mm]	Number of teeth
	with tiewrap plates	without tiewrap plates	with tiewrap plates	without tiewrap plates			
025.	▶ 2020.34PZB	2020.34PZ	2020.12PZB	2020.12PZ	41	12	3
038.	▶ 2030.34PZB	2030.34PZ	2030.12PZB	2030.12PZ	54	25	4
057.	▶ 2050.34PZB	2050.34PZ	2050.12PZB	2050.12PZ	73	44	6
077.	▶ 2070.34PZB	2070.34PZ	2070.12PZB	2070.12PZ	93	64	8
089.	▶ 2090.34PZB	2090.34PZ	2090.12PZB	2090.12PZ	105	77	9
103.	▶ 2100.34PZB	2100.34PZ	2100.12PZB	2100.12PZ*	119	90	10
125.	▶ 2125.34PZB*	2125.34PZ*	2125.12PZB*	2125.12PZ*	141	112	12

*Width available upon request. Please consult igus® for delivery time.
 Full set with tiewrap plate + 10 cable tiewraps, please add index K₁. Example: 2020³⁴PZBK₁

Width Index	Part No. full set KMA			A [mm]	B [mm]	Bi	Number of teeth
	with tiewrap plates both ends pivoting	with tiewrap plates one end pivoting	with tiewrap plates both ends locking				
025.	▶ E2.260.025.34ZB	E2.260.025.56ZB	E2.260.025.12ZB	36	45	25	3
038.	▶ E2.260.038.34ZB	E2.260.038.56ZB	E2.260.038.12ZB	49	58	38	4
057.	▶ E2.260.057.34ZB	E2.260.057.56ZB	E2.260.057.12ZB	68	77	57	6
077.	▶ E2.260.077.34ZB	E2.260.077.56ZB	E2.260.077.12ZB	88	97	77	8
089.	▶ E2.260.089.34ZB	E2.260.089.56ZB	E2.260.089.12ZB	100	109	89	9
103.	▶ E2.260.103.34ZB	E2.260.103.56ZB	E2.260.103.12ZB	114	123	103	10
125.	▶ E2.260.125.34ZB*	E2.260.125.56ZB*	E2.260.125.12ZB*	136	145	125	12

*Width available upon request. Please consult igus® for delivery time.
 Full set with tiewrap plate + 10 cable tiewraps, please add index K₁. Example: 2020³⁴PZBK₁

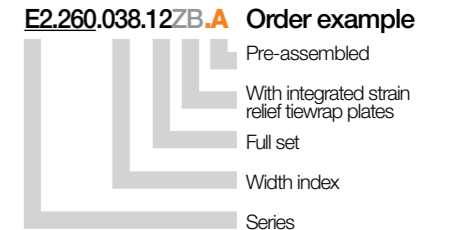
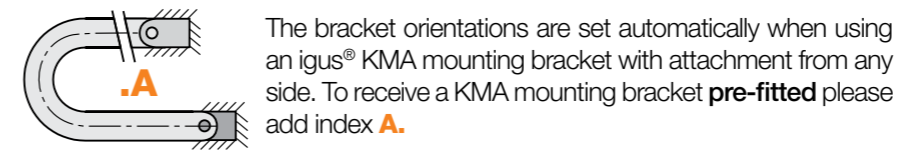
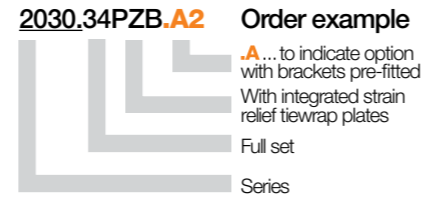
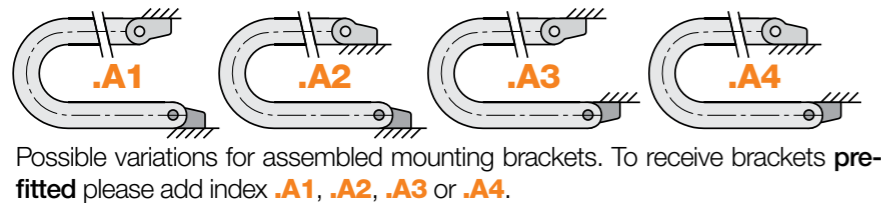

Strain relief e.g. clamps, tiewrap plates, nuggets and clips are available from stock.

Strain relief e.g. clamps, tiewrap plates, nuggets and clips are available from stock.

E2.1 | E2i.26-E2.26 | Accessories Interior separation | Increase cable service life

This product replaces the 2400/2500 series

2

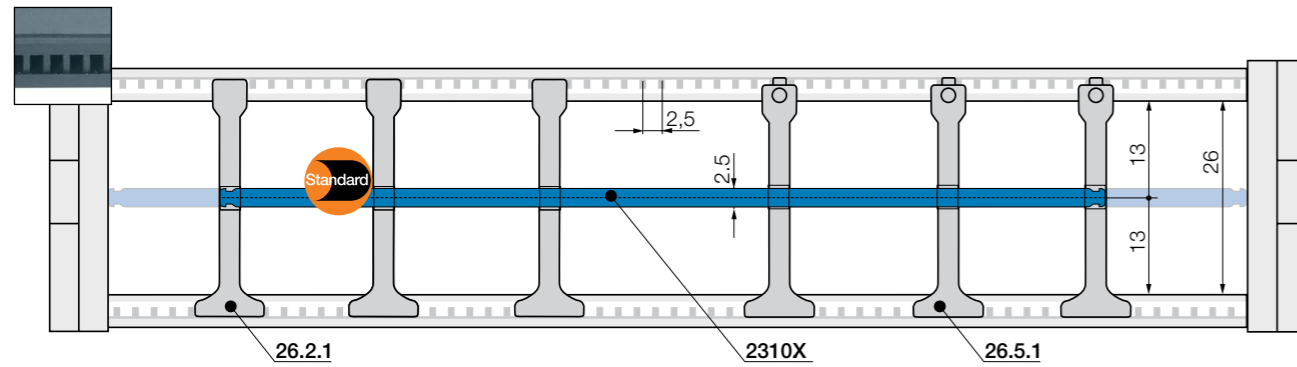

No lateral gap to side links necessary. As standard separators are fitted every 2nd e-chain® link!

Separator, narrow top	
unassembled	26.2
assembled	26.2.1

For even faster installation

Wide on one side for high holding force, narrow on opposite side for easy cable fitting.

Notch separator for notched crossbar	
unassembled	26.5
assembled	26.5.1

Locks securely in preset increments

Notch separator for exact positioning. Recommended for side-mounted applications.

Shelf, lockable	
unassembled	2300.X
assembled	2310.X

Horizontal separation

Full-width shelf locks securely into separators at both ends, giving a fixed width. Can be used as full-width or partial shelf.

Shelves

Width = X [mm]

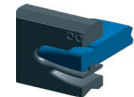

X [mm]	unassembled	assembled	X [mm]	unassembled	assembled	X [mm]	unassembled	assembled
015	2300.015	2310.015	060	2300.060	2310.060	087	2300.087	2310.087
025	2300.025	2310.025	062	2300.062	2310.062	090	2300.090	2310.090
030	2300.030	2310.030	065	2300.065	2310.065	100	2300.100	2310.100
038	2300.038	2310.038	070	2300.070	2310.070	103	2300.103	2310.103
040	2300.040	2310.040	075	2300.075	2310.075	110	2300.110	2310.110
050	2300.050	2310.050	077	2300.077	2310.077	120	2300.120	2310.120
057	2300.057	2310.057	080	2300.080	2310.080	125	2300.125	2310.125

Separator with integrated strain relief teeth

- Can be integrated into the mounting bracket or placed at any point
- Combines strain relief and interior separation, for restricted space conditions
- Strain relief separator is easy to assemble without any screws

Part No. 26.Z



E2.1 | e-chain® with extender crossbar Guidance for hydraulic hoses

E2.1 e-chain® with extender crossbars - guidance for hydraulic hoses

- Safe, space-saving guidance of two hydraulic hoses
 - Special solution for heavy machinery, e.g. for elevating work platforms
 - Very hose-friendly guidance due to optimised inner contours of the e-chain®.
- More information ► www.igus.eu/hydraulicchain



2



E2.1 e-chain® with extender crossbars, guidance for hydraulic hoses - can be fitted along supporting legs, **more information** ► www.igus.eu/hydraulicchain

E2.1 | **E2i.38·E2.38** | Product range
The strong all-rounder, easy to open



This product replaces the 2600/2700 series



2

e-chains® | **Series E2i.38** | Crossbars openable along the inner radius, from both sides
e-chains® | **Series E2.38** | Crossbars openable along the outer radius, from both sides

Part No. e-chains® openable along inner radius		Part No. e-chains® openable along outer radius		<i>B_i</i>	<i>B_a</i>	<i>R</i> Available bend radii										E2.38	E2i.38
				mm	mm											[kg/m]	[kg/m]
E2i.38.	050	.R.0	E2.38.	050	.R.0	50	67	063	075	100	125	150	175	200	250	≈ 1.01	≈ 1.01
E2i.38.	065	.R.0	E2.38.	065	.R.0	65	82	063	075	100	125	150	175	200	250	≈ 1.08	≈ 1.08
E2i.38.	075	.R.0	E2.38.	075	.R.0	75	92	063	075	100	125	150	175	200	250	≈ 1.12	≈ 1.12
E2i.38.	090	.R.0	E2.38.	090	.R.0	90	107	063	075	100	125	150	175	200	250	≈ 1.19	≈ 1.19
E2i.38.	100	.R.0	E2.38.	100	.R.0	100	117	063	075	100	125	150	175	200	250	≈ 1.22	≈ 1.22
E2i.38.	125	.R.0	E2.38.	125	.R.0	125	142	063	075	100	125	150	175	200	250	≈ 1.33	≈ 1.33
E2i.38.	150	.R.0	E2.38.	150	.R.0	150	167	063	075	100	125	150	175	200	250	≈ 1.44	≈ 1.44
E2i.38.	175	.R.0	E2.38.	175	.R.0	175	192	063	075	100	125	150	175	200	250	≈ 1.55	≈ 1.55

Reduce assembly time - E2.1 e-chain® opener

- igus® e-chain® opener for rapid opening in seconds
- Reduce opening times from 33 to 2 seconds
- Open a long e-chain® section in one go
- Part No. **EO.E2.38** available for series E2.38



Aluminium support tray

- Corrosion-resistant and seawater-resistant aluminium rails with adjustable width
- Noise-reducing glide strip integrated as standard
- Easy installation and connection of the e-chain®
- Open design - dirt and debris fall through

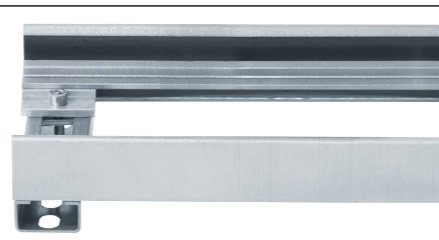

E2.1 | **E2i.38·E2.38** | Installation dimensions
Unsupported applications | **Short travels**



2

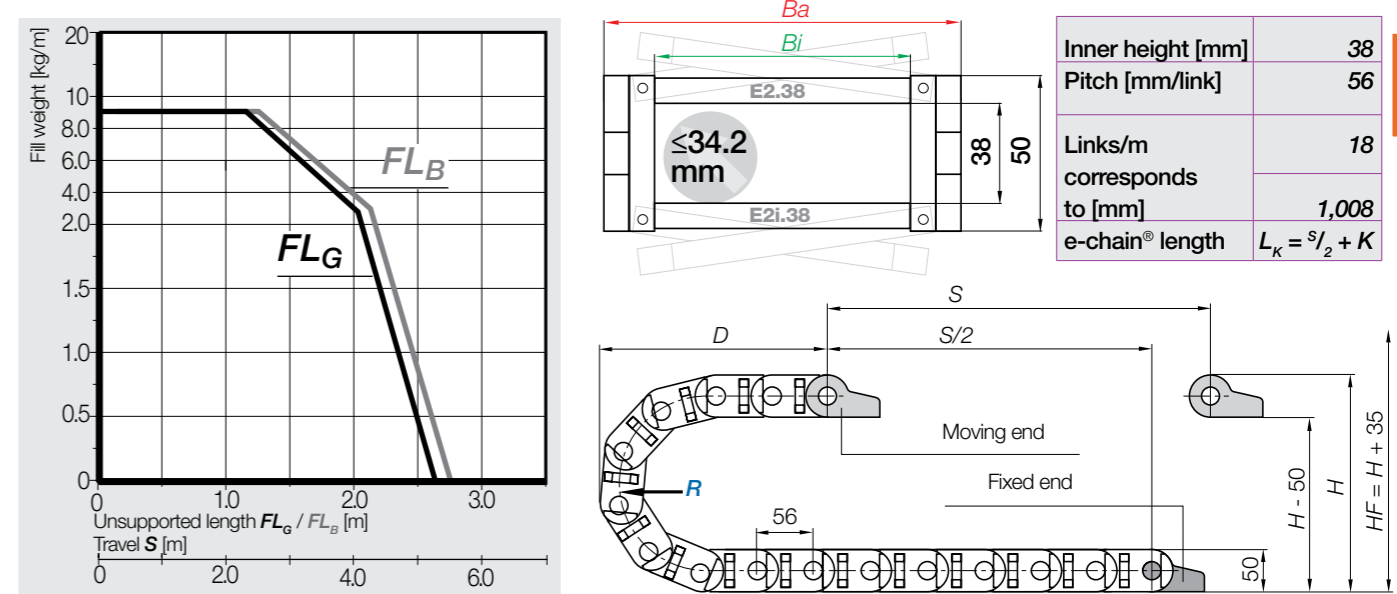

Inner height [mm]	38
Pitch [mm/link]	56
Links/m corresponds to [mm]	18
e-chain® length	$L_K = S/2 + K$

<i>R</i>	063	075	100	125	150	175	200	250
<i>H</i>	176	220	250	300	350	400	450	550
<i>D</i>	172	184	209	234	259	284	309	359
<i>K</i>	310	350	430	505	585	665	745	900

The required clearance height: $HF = H + 35$ mm (with 2.5kg/m fill weight)
Before using series E2i.38 on long travels please consult Treotham®.

Gliding applications | **For travel lengths 10m to max. 120m**

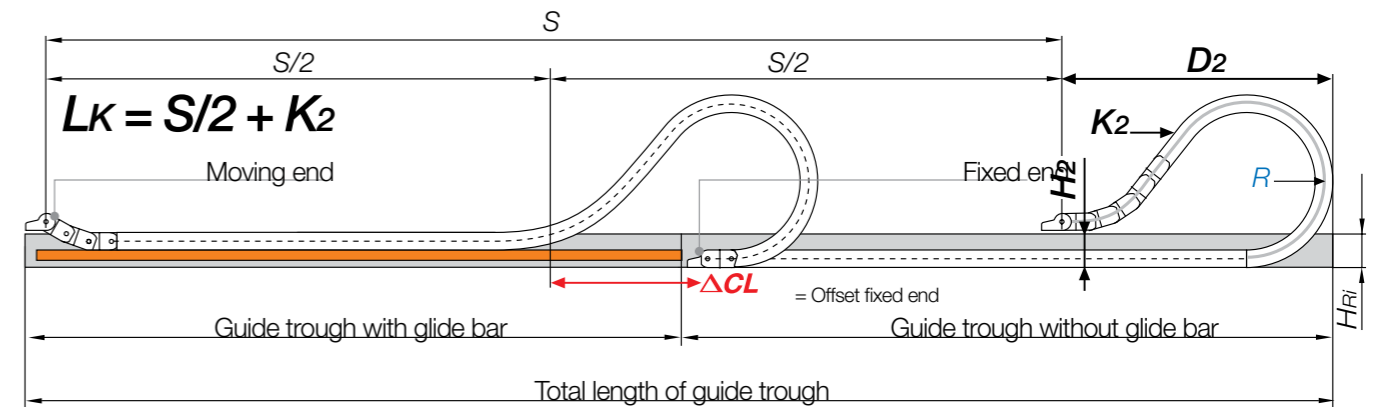

Note: Before using series E2i.38 on long travels please consult Treotham.
For long travels, igus® recommends series E2.38 openable along the outer radius.
In case of travels between 5 and 10m we recommend an e-chain® with a longer unsupported length.

<i>R</i>	063	075	100	125	150	175	200	250
H_2	176	200	166	166	166	166	166	166
D_2^{25}	172	184	395	510	545	700	805	995
K_2	310	350	616	784	896	1,120	1,288	1,624
ΔCL	-	-	144	244	244	374	464	594

E2.1 | **E2i.38-E2.38** | Accessories
 Mounting brackets, polymer | **Pivoting** | Locking

This product replaces the 2600/2700 series

2

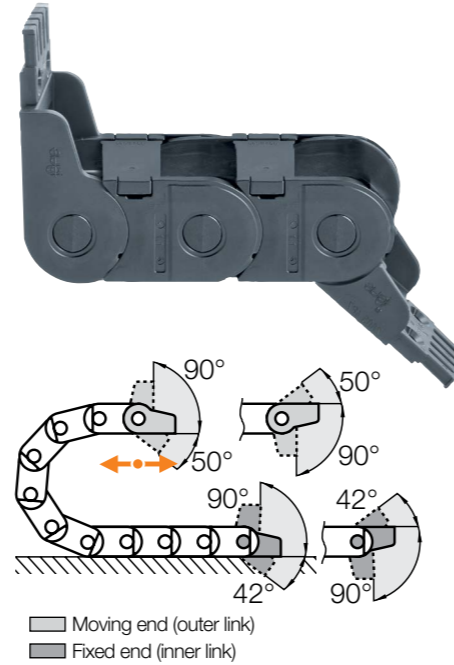
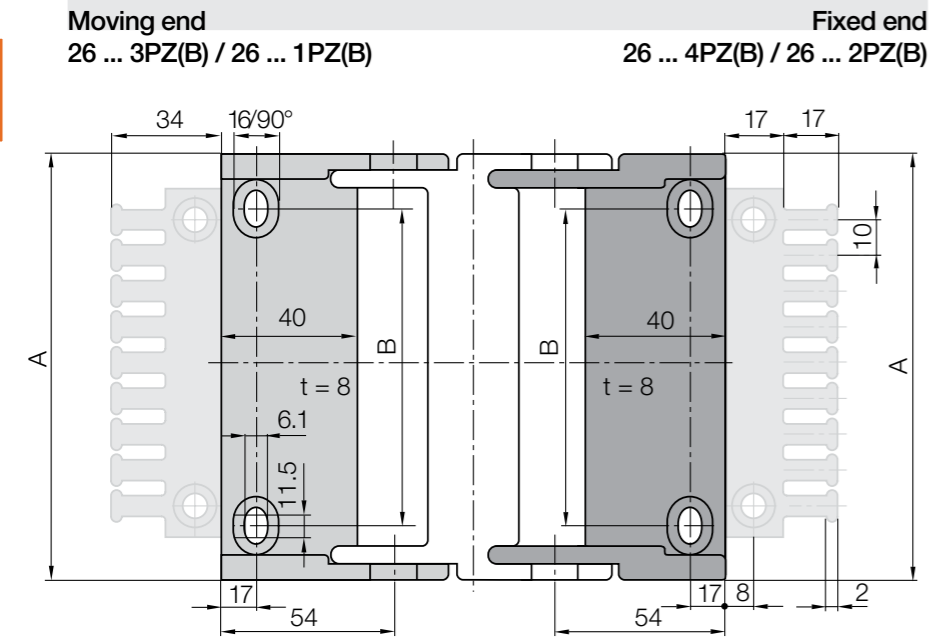

Polymer pivoting | Recommended for unsupported and gliding applications
Polymer locking | Recommended for vertical hanging and standing applications

Width index	Part No. full set pivoting		Part No. full set locking		A [mm]	B [mm]	Number of teeth
	with tiewrap plates	without tiewrap plate	with tiewrap plates	without tiewrap plate			
050.	2605.34PZB	2605.34PZ	2605.12PZB	2605.12PZ	68	30	5
065.	2606.34PZB	2606.34PZ	2606.12PZB	2606.12PZ	83	45	5
075.	2607.34PZB	2607.34PZ	2607.12PZB	2607.12PZ	93	55	7
090.	2609.34PZB	2609.34PZ	2609.12PZB	2609.12PZ	108	70	9
100.	2610.34PZB	2610.34PZ	2610.12PZB	2610.12PZ	118	80	10
125.	2612.34PZB	2612.34PZ	2612.12PZB	2612.12PZ	143	105	12
150.	2615.34PZB	2615.34PZ	2615.12PZB	2615.12PZ	168	130	15
175.	2617.34PZB	2617.34PZ	2617.12PZB	2617.12PZ	193	155	17

*Width available upon request. Please consult igus® for delivery time.

Full set with tiewrap plate + 10 cable tiewraps, please add index K1. Example: 2606.34PZBK1

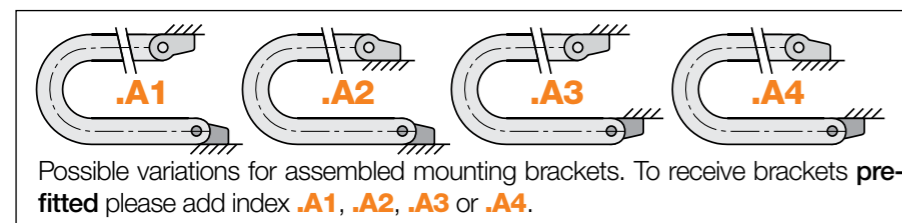

2606.34PZB.A1 Order example



E2.1 | **E2i.38-E2.38** | Accessories
 Interior separation | **Increase cable service life**

2

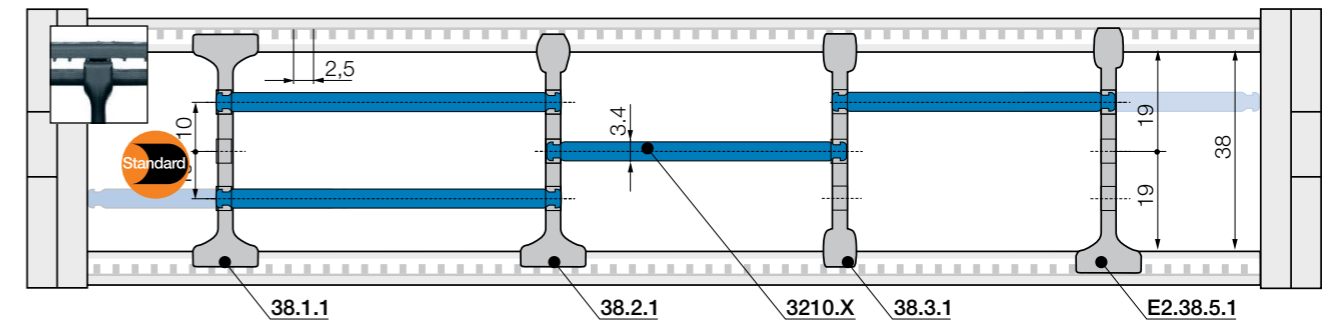

No lateral gap to side links necessary. As standard separators are fitted every 2nd e-chain® link!

Standard separator, wide base	
unassembled	38.1
assembled	38.1.1

Standard - for any application

Separator with a wide base for maximum holding force.

Shelf, lockable	
unassembled	3200.X
assembled	3210.X

Horizontal separation

Full-width shelf locks securely into separators at both ends, giving a fixed width. Can be used as full-width or partial shelf.

Shelves Width = X [mm]	X [mm]	Unassembled		Assembled		X [mm]	Unassembled		Assembled	
		Part No.	Part No.	Part No.	Part No.		Part No.	Part No.		
	050	3200.050	3210.050	125	3200.125	3210.125	225	3200.225	3210.225	
	075	3200.075	3210.075	150	3200.150	3210.150	250	3200.250	3210.250	
	100	3200.100	3210.100	175	3200.175	3210.175				
	115	3200.115	3210.115	200	3200.200	3210.200				

E2.1 | **E2i.38-E2.38** | Accessories Interior separation | To allow faster filling

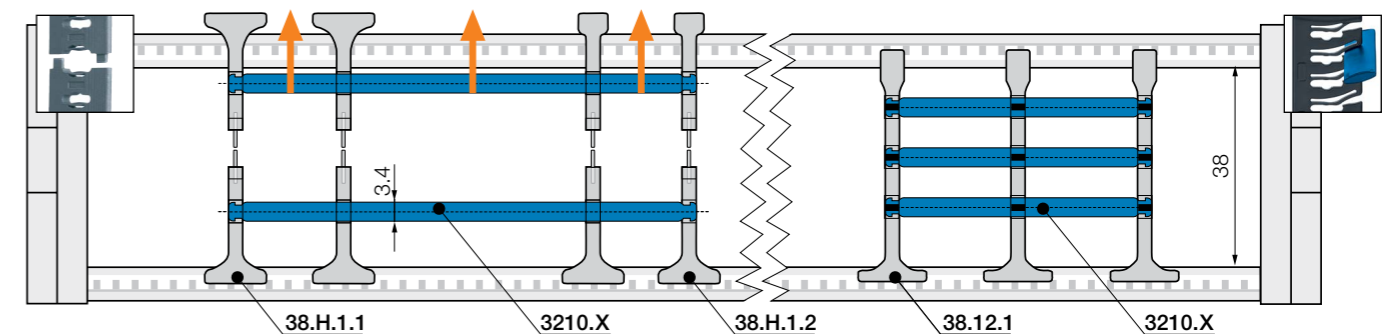

No lateral gap to side links necessary. As standard separators are fitted every 2nd e-chain® link!

Split separator, wide base/top	
unassembled	38.H.1
assembled	38.H.1.1

Lean separator¹⁾	
unassembled	38.12
assembled	38.12.1

With the lean separator you can quickly insert several layers of cables into the e-chain® and reduce the installation time by up to 50%²⁾.

2) Lean interior separation vs. Standard separator - measured on a 4m long e-chain® fitted with 12 cables in the igus® readychain® factory

E2.1 | **E2i.48·E2.48** | Product range The strong all-rounder, easy to open

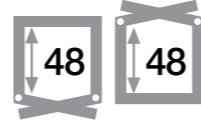

This product replaces the 3400/3500 series



e-chains® | **Series E2i.48** | Crossbars openable along the inner radius, from both sides
 e-chains® | **Series E2.48** | Crossbars openable along the outer radius, from both sides

Order configuration and dimensions																	
Part No. e-chains® openable along inner radius		Part No. e-chains® openable along outer radius		Bi [mm]	Ba [mm]	R									E2.48 [kg/m]	E2i.48 [kg/m]	
E2i.48.	050	R.0	E2.48.	050	R.0	50	76	075	100	125	150	175	200	250	300	≈ 1.77	≈ 1.77
E2i.48.	075	R.0	E2.48.	075	R.0	75	97	075	100	125	150	175	200	250	300	≈ 1.86	≈ 1.86
E2i.48..	100	R.0	E2.48.	100	R.0	100	122	075	100	125	150	175	200	250	300	≈ 2.00	≈ 2.00
E2i.48..	115	R.0	E2.48.	115	R.0	115	137	075	100	125	150	175	200	250	300	≈ 2.06	≈ 2.06
E2i.48.	125	R.0	E2.48.	125	R.0	125	147	075	100	125	150	175	200	250	300	≈ 2.12	≈ 2.12
E2i.48.	150	R.0	E2.48.	150	R.0	150	172	075	100	125	150	175	200	250	300	≈ 2.24	≈ 2.24
E2i.48.	175	R.0	E2.48.	175	R.0	175	197	075	100	125	150	175	200	250	300	≈ 2.36	≈ 2.36
E2i.48..	200	R.0	E2.48.	200	R.0	200	222	075	100	125	150	175	200	250	300	≈ 2.48	≈ 2.48
E2i.48.	225	R.0	E2.48.	225	R.0	225	247	075	100	125	150	175	200	250	300	≈ 2.60	≈ 2.60
E2i.48.	250	R.0	E2.48.	250	R.0	250	272	075	100	125	150	175	200	250	300	≈ 2.72	≈ 2.72

Width available upon request. Please consult igus® for delivery time.

Complete Part No. with required radius (R). Example: E2.48.075.075.0

Steel support tray for support of the lower run

Simple one-piece support trays for the lower run
 To your requirements and specification
 4 options available

More information contact your nearest Treotham Office.

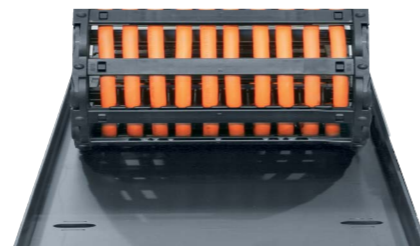

E2.1 | **E2i.48·E2.48** | Installation dimensions
 Unsupported applications | **Short travels**

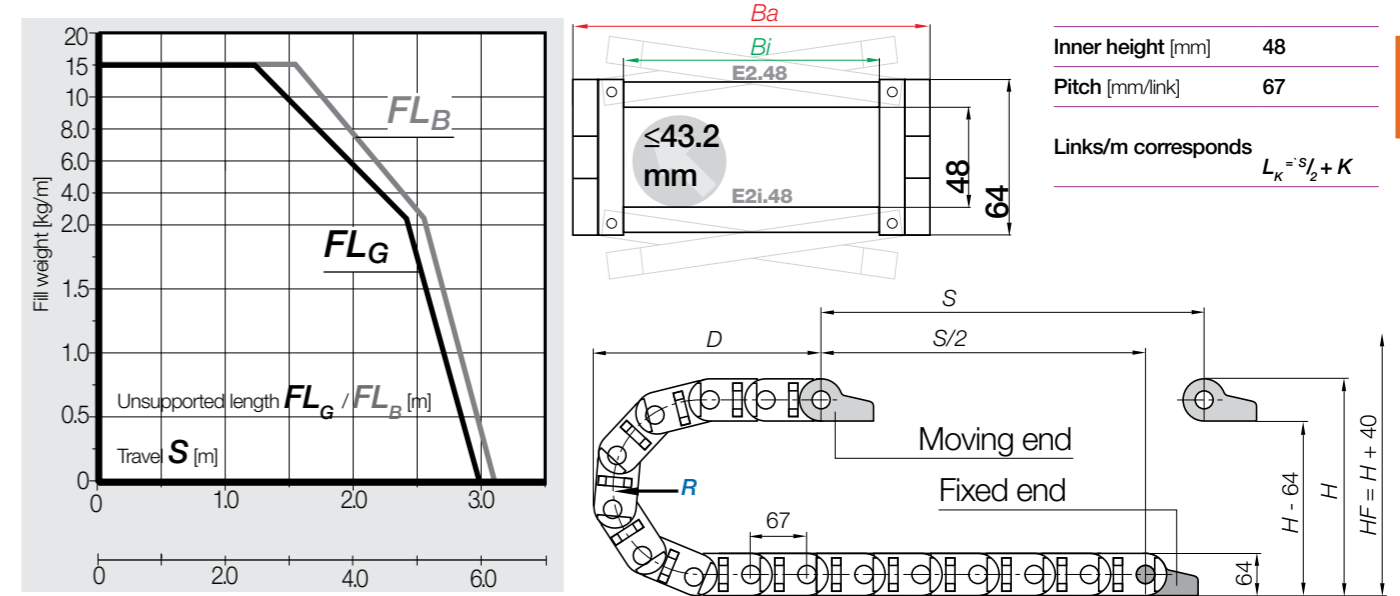
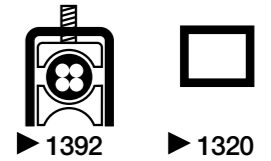

R	075	100	125	150	175	200	250	300
H	214	264	314	364	414	464	564	664
D	208	233	258	283	308	333	383	433
K	370	450	530	610	685	765	920	1080

The required clearance height: $H_f = H + 40$ mm (with 2.5kg/m fill weight)

Before using series E2i.48 on long travels please consult igus®.

Gliding applications | For travel lengths 10m to max. 150m

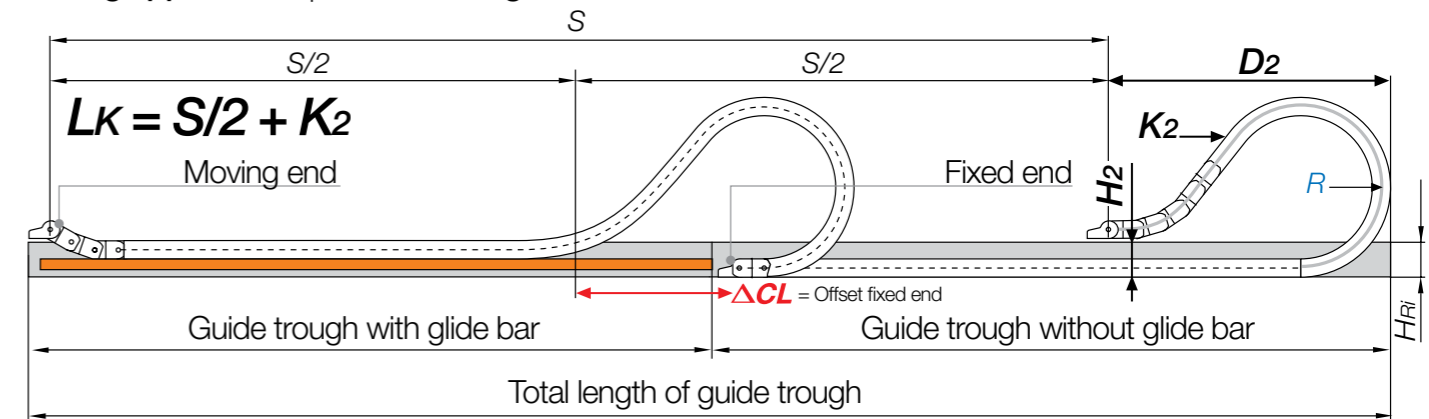

Note: Before using series E2i.48 on long travels please consult igus®.

For long travels, igus® recommends series E2.48 openable along the outer radius.

In case of travels between 6 and 10m we recommend an e-chain® with a longer unsupported length.

R	075	100	125	150	175	200	250	300
H ₂	214	264	186	186	186	186	186	186
D ₂ ⁺²⁵	208	233	475	570	725	780	1,010	1,150
K ₂	370	450	804	1,005	1,072	1,340	1,675	1,943
ΔCL	-	-	233	303	433	463	643	733

E2.1 | **E2i.48-E2.48** | Accessories Mounting brackets, polymer | Pivoting | Locking

2

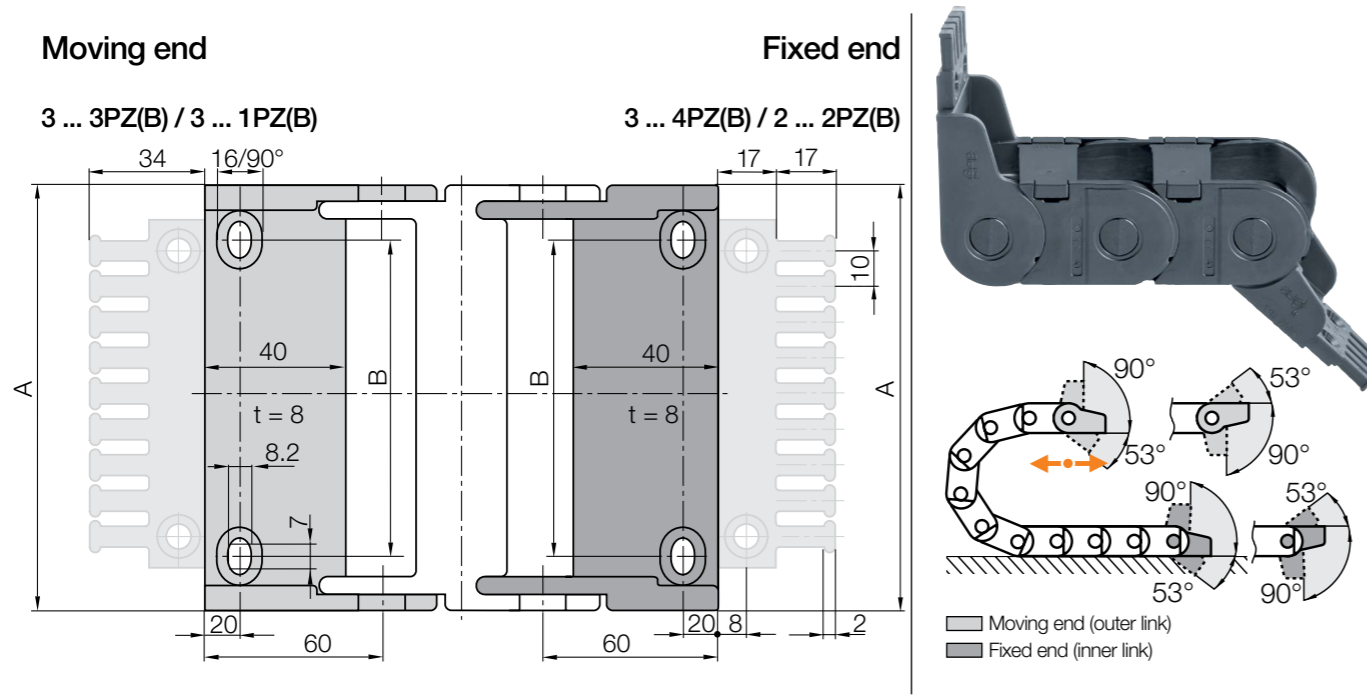

Polymer pivoting | **Recommended for** unsupported and gliding applications
 Polymer locking | **Recommended for** vertical hanging and standing applications

Width index	Part No. full set pivoting		Part No. full set locking		A [mm]	B [mm]	Number of teeth
	with tiewrap plates	without tiewrap plate	with tiewrap plates	without tiewrap plate			
050.	3050.34PZB*	3050.34PZ*	3050.12PZB*	3050.12PZ*	71	28	5
075.	3075.34PZB	3075.34PZ	3075.12PZB	3075.12PZ	96	53	7
100.	3100.34PZB	3100.34PZ	3100.12PZB	3100.12PZ	121	78	10
115.	3115.34PZB	3115.34PZ	3115.12PZB	3115.12PZ	136	93	11
125.	3125.34PZB*	3125.34PZ*	3125.12PZB*	3125.12PZ*	146	103	12
150.	3150.34PZB	3150.34PZ	3150.12PZB	3150.12PZ	171	128	15
175.	3175.34PZB	3175.34PZ	3175.12PZB	3175.12PZ	196	153	17
200.	3200.34PZB*	3200.34PZ*	3200.12PZB*	3200.12PZ*	221	178	20
225.	3225.34PZB*	3225.34PZ*	3225.12PZB*	3225.12PZ*	246	203	22
250.	3250.34PZB*	3250.34PZ*	3250.12PZB*	3250.12PZ*	271	228	25

*Width available upon request. Please consult igus® for delivery time.
 Full set with tiewrap plate + 10 cable tiewraps, please add index K1. Example: 3275.34PZBK1

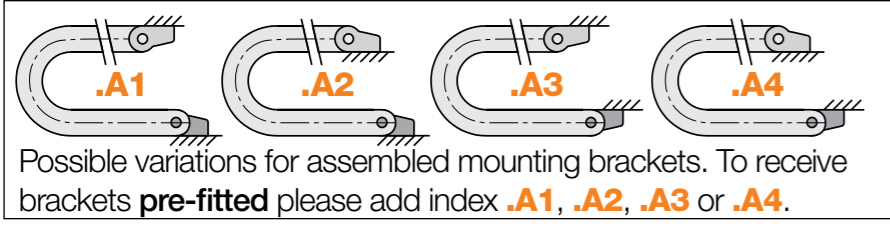

Order example
3075.34PZB.A2
 .A... to indicate option with brackets pre-fitted
 With integrated strain relief tiewrap plates
 Full set
 Series

Strain relief e.g. clamps, tiewrap plates, nuggets and clips are available from stock.
The complete chainfix range with ordering options.

E2.1 | **E2i.48-E2.48** | Accessories Interior separation | Increase cable service life

2

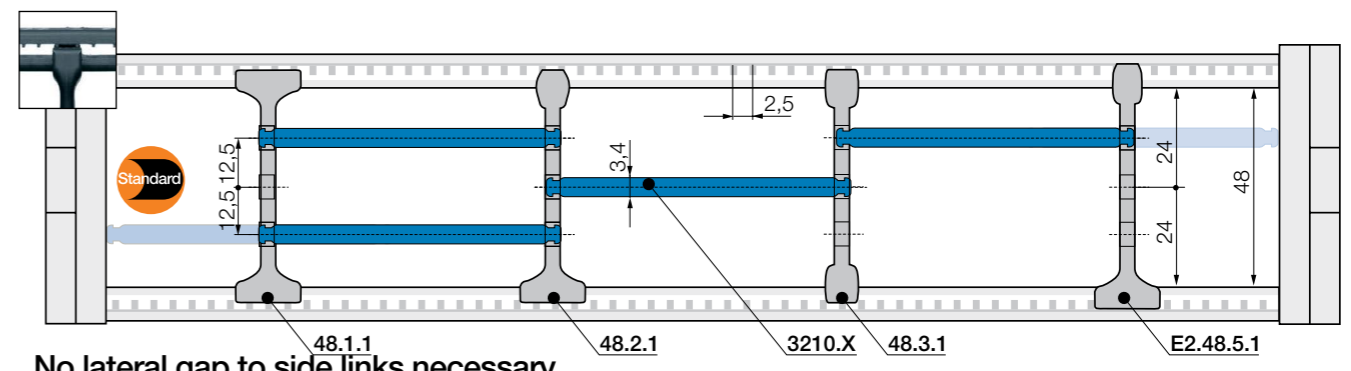

No lateral gap to side links necessary.
 As standard separators are fitted every 2nd e-chain® link!

Standard separator, wide base
 unassembled 48.1
 assembled 48.1.1

Standard - for any application
 Separator with a wide base for maximum holding force.

Shelves Width = X [mm]	X [mm]	Unassembled		Assembled		X [mm]	Unassembled		Assembled	
		Part No.	Part No.	Part No.	Part No.		Part No.	Part No.		
	050	32000.050	3210.050	125	3200.125	3210.125	225	3200.225	3210.225	
	075	3200.075	3210.075	150	3200.150	3210.150	250	3200.250	3210.250	
	100	3200.100	3210.100	175	3200.175	3210.175				
	115	3200.115	3210.115	200	3200.200	3210.200				



Crossbar with integrated grid and openable from both ends - from the top or the side with a screwdriver

E2.1 | E2i.48-E2.48 | Accessories Interior separation | To allow faster filling

2

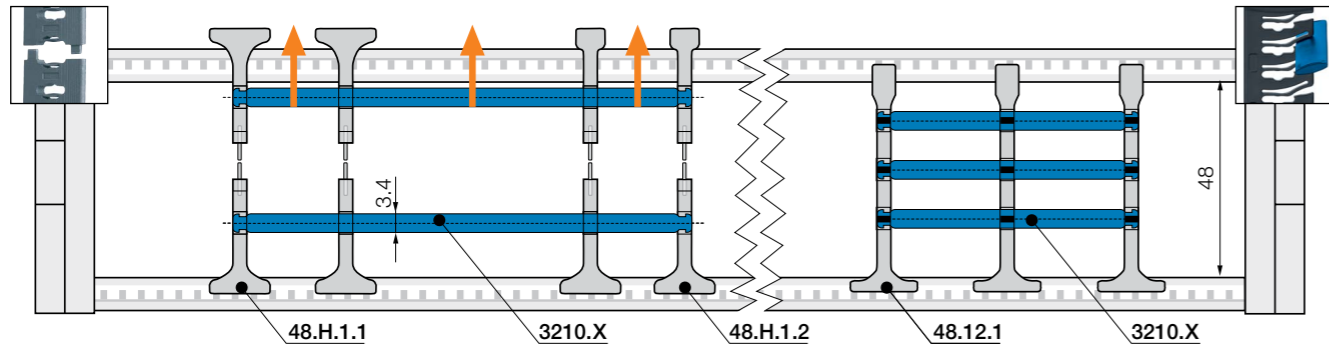

No lateral gap to side links necessary.
As standard separators are fitted every 2nd e-chain® link!

Split separator, wide base/top

unassembled	48.H.1
assembled	48.H.1.1

Split separators

In order to fill e-chains® more easily and effectively, these separators can be split in the middle. This allows easier access to middle shelf partitions. Fast assembly and easy retrofit. 2 types available: with wide or narrow top.

Lean separators¹⁾

For quick fitting of shelves in several layers.

1) Note: Please combine maximum 4 lean separators with one shelf. Not suitable for side-mounted e-chains®!



With the lean separator you can quickly insert several layers of cables into the e-chain® and reduce the installation time by up to 50%²⁾.

2) Lean interior separation vs. Standard separator - measured on a 4m long e-chain® fitted with 12 cables in the igus® readychain® factory

E2.1 | Application example

CFU strain relief with innovative honeycomb design

- Fast filling, openable from both sides for assembly in seconds
- Flexible honeycomb design for increased holding force
- Tribologically optimised honeycomb design for the best hold
- Universal use, compact, space-saving design

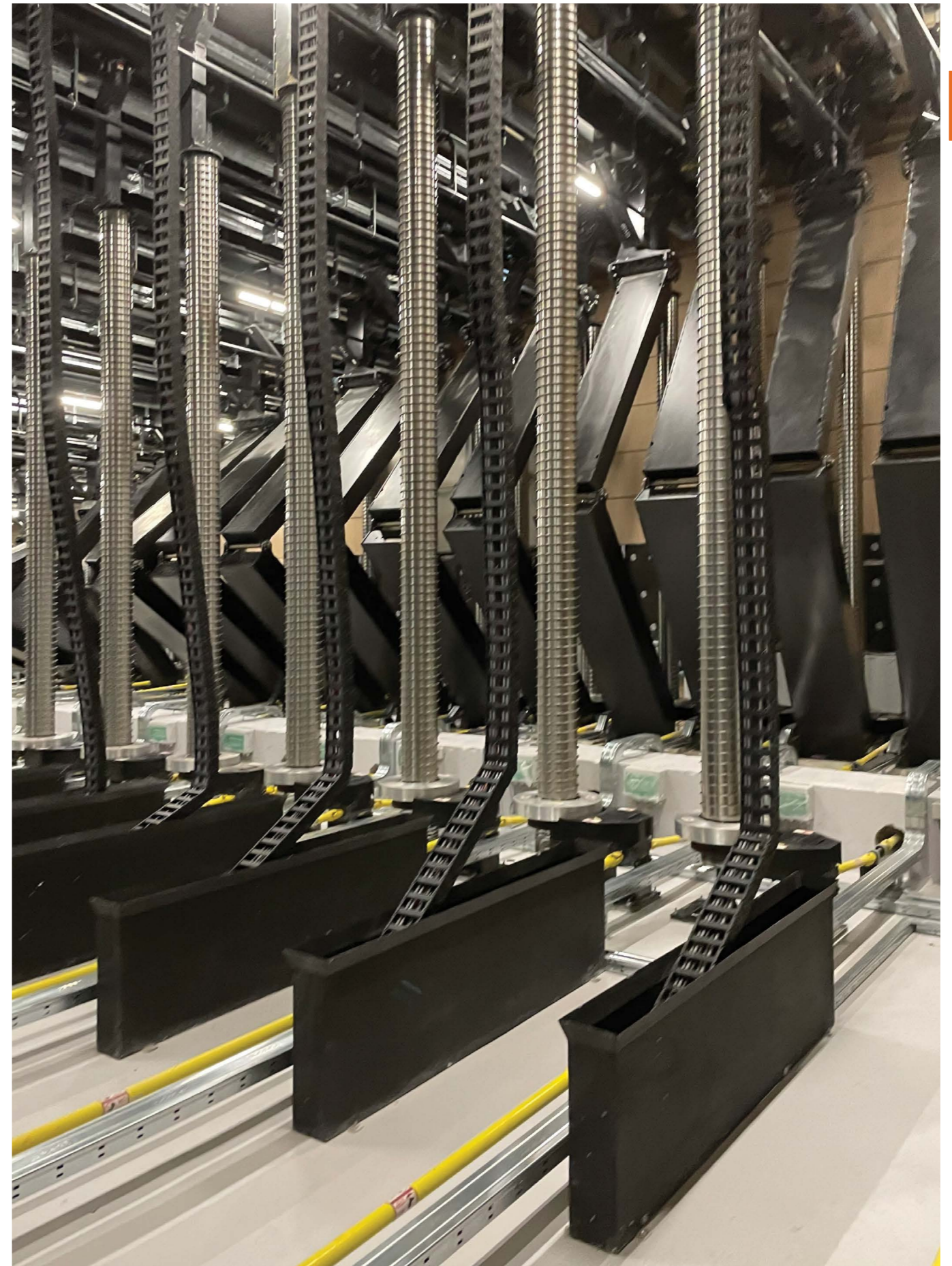

2

E2 E-Tubes | Series R48

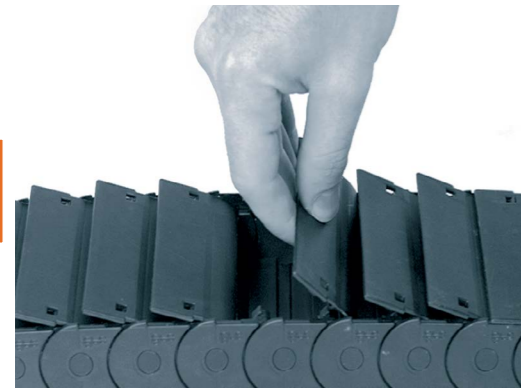

- 1 Protection for cables and hoses, against hot chips
- 2 Removable lids along outer radius
- 3 Large pins for high stability
- 4 Smooth, chip-repellent exterior
- 5 Small pitch for low-noise, smooth operation
- 6 Fully enclosed
- 7 KMA mounting brackets with attachment capability on all sides
- 8 Strain relief separator - Separator with integrated strain relief for the use in the first or last chain link

When to use the Series R48:

- If particularly quiet operation is required
- At very high speed
- If chip-repellent features are required

When not to use it:

- If a particularly low-cost solution is the main factor
- If no chip protection is required

Series 2400/2500 E2/000, page 162

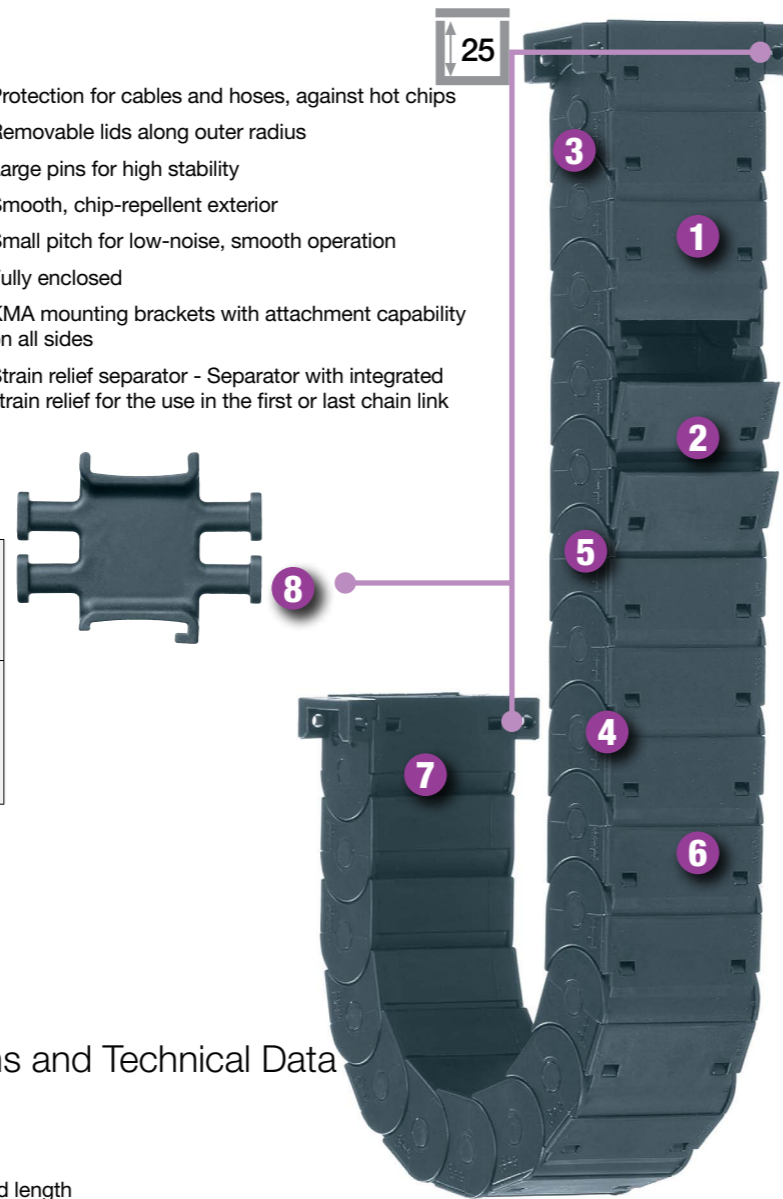

E2 E-Tubes | Series R48 | Dimensions and Technical Data

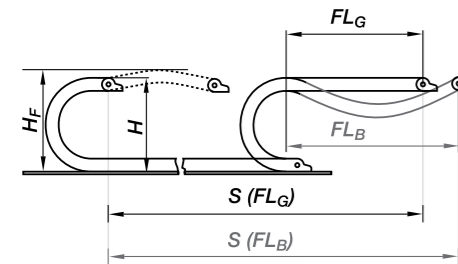

Unsupported length
 FL_G = with straight upper run
 FL_B = with permitted sag

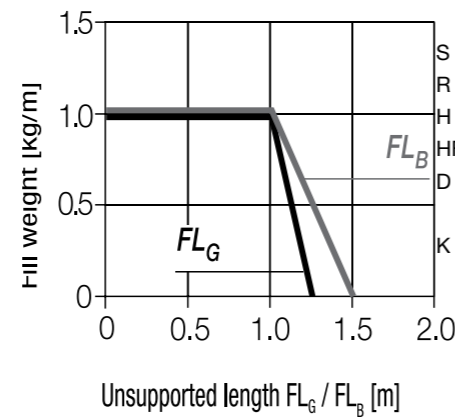
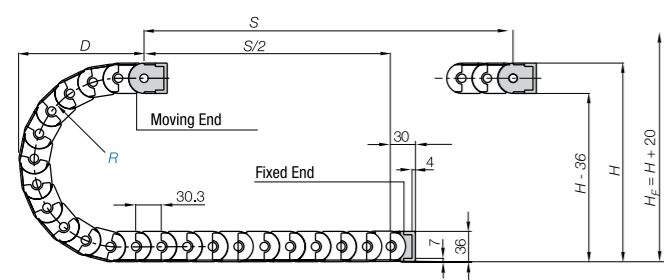

S = Length of travel
 R = Bending radius
 H = Nominal clearance height
 HF = Required clearance height
 D = Overlength E-Chain® radius in final position
 K = $\pi \cdot R + \text{"safety"}$

Pitch = 30,3 mm/link Links/m = 33 (999,9 mm) Chain length = S/2 + K

	060	075	100	125	150	175	200	250
R	060	075	100	125	150	175	200	250
H	156	186	236	286	336	386	436	536
D	123	138	163	188	213	238	263	313
K	250	300	375	455	535	610	690	850

E2 E-Tubes | Series R48 | Product Range

Series R48 - snap-open along outer radius

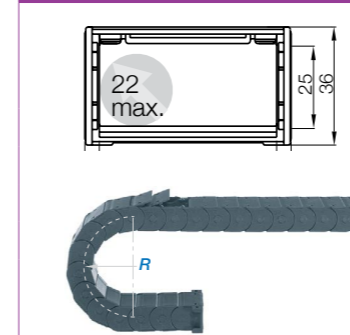

Part No	Bi[mm]	Ba[mm]	R[mm] Bending Radii							
			060	075	100	125	150	175	200	250
48.025. .0	25	36	060	075	100	125	150	175	200	250
48.050. .0	50	61	060	075	100	125	150	175	200	250
48.075. .0	75	86	060	075	100	125	150	175	200	250
48.100. .0	100	111	060	075	100	125	150	175	200	250
48.130. .0	130	141	060	075	100	125	150	175	200	250

Supplement Part No. with required radius. Example: 48.100.100.0

E2 E-Tubes | Series R48 | Accessories | Interior Separation

Vertical Separator	
Unassembled	481

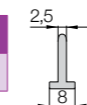

Strain Relief Separator	
Unassembled	481.ZR

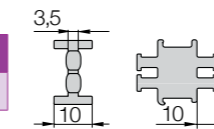

Option 1: Vertical Separators

Vertical Separators are used if a vertical subdivision of the E-Chain® interior is required:

- Standard subdivision with Vertical Separator 481
- Strain Relief Separator 481.ZR, integrable in the mounting bracket, to position at any point.

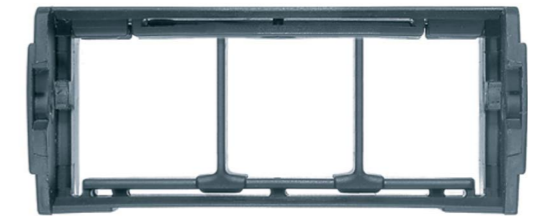
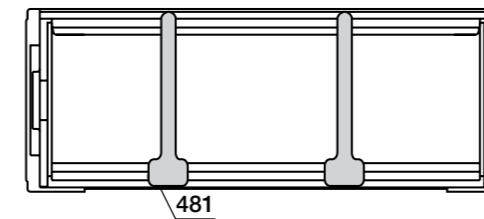

E2 E-Tubes | Series R48 | Accessories | Mounting Brackets



Pivoting

- Recommended for unsupported applications
- Bolted connection outside of chain cross-section possible
- Space-restricted
- Universal mountable with attachment capability on all sides
- Mounting-surfaces can be used on the upper side or front side

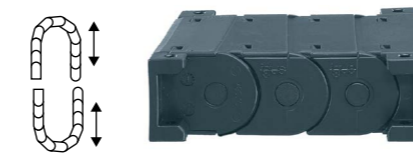
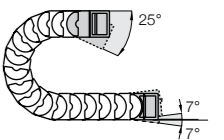

Locking

- Recommended for vertical hanging / standing applications
- Bolted connection outside of chain cross-section possible
- At very high speed and acceleration
- Universal mountable with attachment capability on all sides
- Mounting-surfaces can be used on the upper side or front-sided

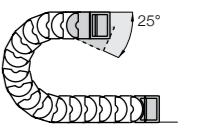

Order configuration and dimensions

E-Chain Part No.	Bracket Part No.	Dim. A [mm]	Dim. B [mm]
48.025	.025.12	45	55
48.050	.050.12	70	80
48.075	.075.12	95	105
48.100	.100.12	120	130
48.130	.130.12	150	160

Please add the Part No. with the requested index - 480 for the pivoting configuration e.g. 480.025.12 or 485 for the locking configuration e.g. 485.025.12

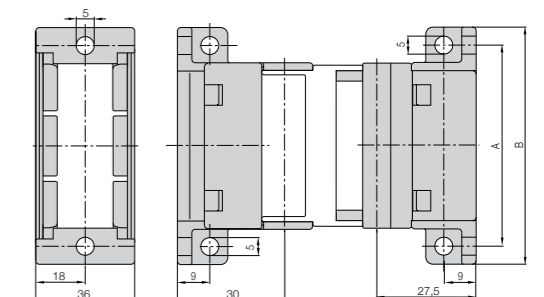

E4.1 light | Series E4.31L·R4.31L | Product range

For low and medium loads, light and cost-effective



e-chains® | E4.31L crossbars every link (pivotable on both sides, snap-open along inner and outer radius)
 e-tubes | R4.31L fully enclosed (pivotable on both sides, snap-open along inner and outer radius)

Order configuration and dimensions

Part No. e-chains®	Part No. e-tubes	Bi	Ba [mm]	E4.31L [kg/m]	R4.31L [kg/m]
E4.31L.040.R.0	-	40	54	≈ 0.70	-
E4.31L.050.R.0	R4.31L.050.R.0	50	64	≈ 0.74	≈ 0.87
E4.31L.062.R.0**	-	62.5	76.5	≈ 0.76	-
E4.31L.075.R.0	R4.31L.075.R.0**	75	89	≈ 0.78	≈ 1.01
E4.31L.087.R.0**	-	87.5	101.5	≈ 0.83	-
E4.31L.100.R.0	R4.31L.100.R.0**	100	114	≈ 0.88	≈ 1.10
E4.31L.112.R.0**	-	112.5	126.5	≈ 0.93	-
E4.31L.125.R.0**	R4.31L.125.R.0**	125	139	≈ 0.96	≈ 1.28
E4.31L.137.R.0**	-	137.5	151.5	≈ 0.98	-
E4.31L.150.R.0	R4.31L.150.R.0**	150	164	≈ 1.00	≈ 1.40
E4.31L.162.R.0**	-	162.5	176.5	≈ 1.04	-
E4.31L.175.R.0	R4.31L.175.R.0**	175	189	≈ 1.13	≈ 1.55
E4.31L.187.R.0**	-	187.5	201.5	≈ 1.17	-
E4.31L.200.R.0**	R4.31L.200.R.0**	200	214	≈ 1.17	≈ 1.68

**Available upon request, please consult Treotham for delivery

Available bending radii R (mm) 055¹ | 063¹ | 075 | 100* | 125 | 150 | 175 | 200 | 250* |

¹Radius available upon request, please consult Treotham for delivery time
^{*}Radius not available for e-tubes

Supplement Part No. with required radius (R). Examples:

E4.31L.05.075.0 = e-chain® with inner width Bi 50 mm, radius R 075 mm, colour black

R4.31L.05.075.0 = e-tube fully enclosed with inner width Bi 50 mm, radius R 075 mm, colour black

E4.1 light Series E4.31L·R4.31L Dimensions

Unsupported applications | Short travels

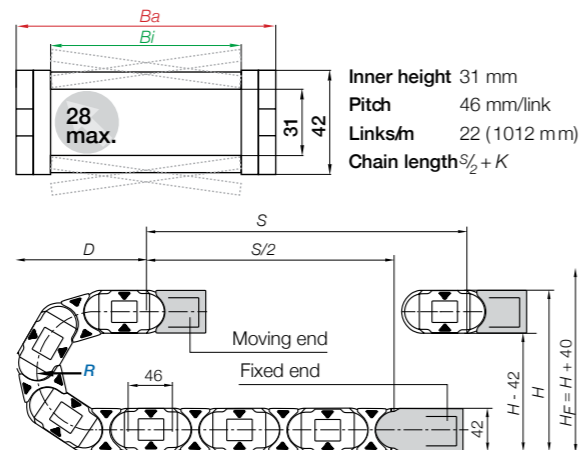
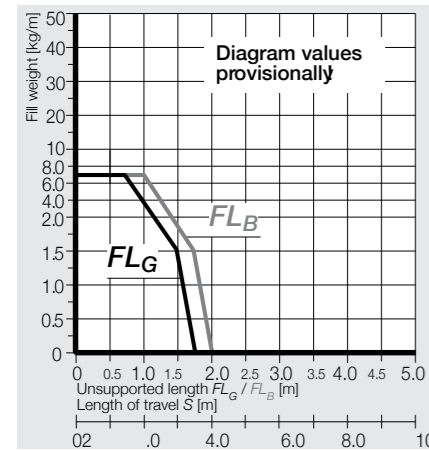

The required clearance height:
 HF = H + 40 mm
 (with 1,0 kg/m fill weight)

Pitch = 46 mm/link Links/m = 22 (1012 mm) Chain length = S/2 + K

	055 ¹	063 ¹	075	100*	125	150	175	200	250*
R									
H	152	168	192	242	292	342	392	442	542
D	145	153	165	190	215	240	265	290	340
K	265	290	330	410	485	565	645	725	880

¹Radius not available for e-tubes • ^{*}Radius available upon request.

E4.1 light | Series E4.31L·R4.31L | Accessories

KMA mounting brackets | Attachment on all sides | Pivoting

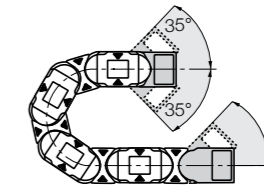
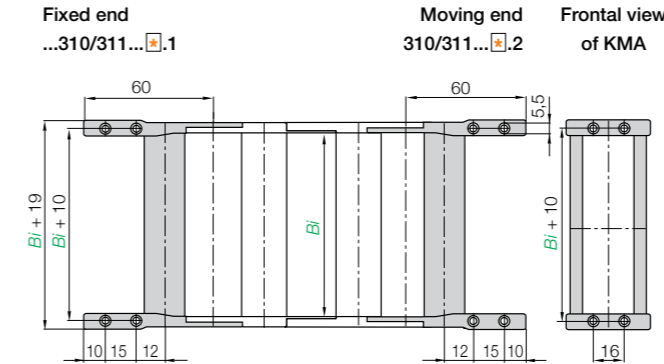

Traverse angle depending on radius.
 For e-tubes, please consult igus®



KMA pivoting | Recommended for unsupported and gliding applications | Standard
 KMA locking | Recommended for vertical hanging and standing applications

Width Index	Part No. full set KMA Pivoting	Part No. full set KMA Locking	Bi (mm)	Width Index	Part No. full set KMA Pivoting	Part No. full set KMA Locking	Bi (mm)
040. ▶	E4. - 310.040. *12.C E4. -	311.040. *12.C	40	125. ▶	E4. R4.** 310.125. *12.C	E4. R4.** 311.125. *12.C	125
050. ▶	E4. R4. 310.050. *12.C E4. R4.	311.050. *12.C	50	137. ▶	E4. - 310.137. *12.C	E4.** - 311.137. *12.C	137.5
062. ▶	E4.** - 310.062. *12.C E4. -	311.062. *12.C	62.5	150. ▶	E4. R4.** 310.150. *12.C	E4. R4.** 311.150. *12.C	150
075. ▶	E4. R4.** 310.075. *12.C E4. R4.**	311.075. *12.C	75	162. ▶	E4. - 310.162. *12.C	E4.** - 311.162. *12.C	162.5
087. ▶	E4. - 310.087. *12.C E4. -	311.087. *12.C	87.5	175. ▶	E4. R4.** 310.175. *12.C	E4. R4.** 311.175. *12.C	175
100. ▶	E4. R4.** 310.100. *12.C E4. R4.**	311.100. *12.C	100	187. ▶	E4. - 311.187. *12.C	E4.** - 311.187. *12.C	187.5
112. ▶	E4.** - 310.112. *12.C E4. -	311.112. *12.C	112.5	200. ▶	E4. R4.** 311.200. *12.C	E4. R4.** 311.200. *12.C	200

**Available upon request, please consult Treotham for delivery

Note ☒: The Part No. depends on an even or odd number of links. Please insert: Index 1 (for odd) or 2 (for even).

The E4.1 may end with either an inner or an outer side link. An outer side link always forms the first e-chain® link at the moving end.

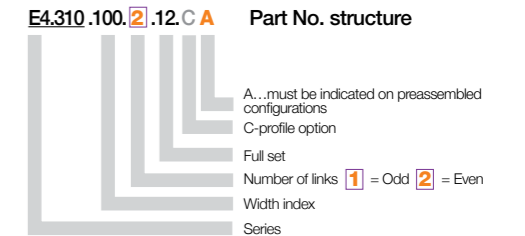
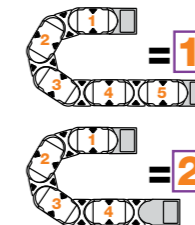

E4.1 Series E4.42 | Product Range

Stable due to undercut design, medium inner height

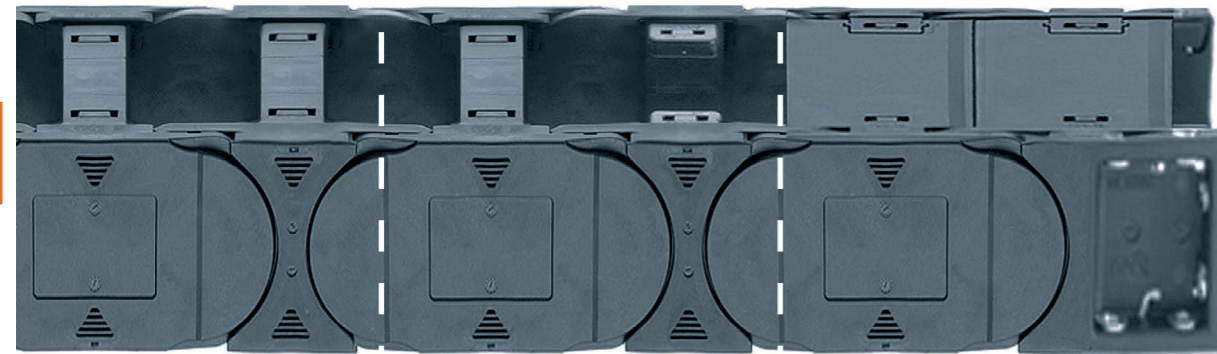

e-chains® | **Series E4.42** crossbars every link (crossbars removable along both radii)

e-chains® | **Series H4.42** crossbars every 2nd link (crossbars removable along both radii)

e-tube® | **Series R4.42** fully enclosed e-tube® (lids are removable along both radii)

Order configuration and dimensions

Part Number. e-chains®		Bi [mm]	Ba [mm]	E4.42 [kg/m]	H4.42 [kg/m]	R4.42 [kg/m]	
E4.42.05.R.0	H4.42.05.R.0	R4.42.05.R.0	50	76	1.923	1.804	2.150
E4.42.06.R.0	H4.42.06.R.0	-	68	94	2.031	1.858	-
E4.42.07.R.0	H4.42.07.R.0	R4.42.07.R.0	75	101	2.059	1.872	2.280
E4.42.087.R.0	H4.42.087.R.0	R4.42.087.R.0	87	114	2.119	1.903	2.410
E4.42.097.R.0	H4.42.097.R.0	-	97	120	2.135	1.919	-
E4.42.10.R.0	H4.42.10.R.0	R4.42.10.R.0	100	126	2.188	1.973	2.520
E4.42.11.R.0	H4.42.11.R.0	R4.42.11.R.0	108	134	2.235	1.960	2.570
E4.42.112.R.0	H4.42.112.R.0	-	112	139	2.247	1.966	-
E4.42.12.R.0	H4.42.12.R.0	R4.42.12.R.0	125	151	2.341	2.014	2.730
E4.42.137.R.0	H4.42.137.R.0	-	137	164	2.385	2.035	-
E4.42.15.R.0	H4.42.15.R.0	R4.42.15.R.0	150	176	2.460	2.073	2.980
E4.42.162.R.0	H4.42.162.R.0	-	162	189	2.484	2.085	-
E4.42.17.R.0	H4.42.17.R.0	R4.42.17.R.0	168	194	2.553	2.119	3.150
E4.42.18.R.0	H4.42.18.R.0	-	175	201	2.571	2.128	-
E4.42.187.R.0	H4.42.187.R.0	R4.42.187.R.0	187	214	2.610	2.148	-
E4.42.20.R.0	H4.42.20.R.0	R4.42.20.R.0	200	226	2.715	2.200	3.450
E4.42.212.R.0	H4.42.212.R.0	-	212	239	2.757	2.221	-
E4.42.23.R.0	H4.42.23.R.0	-	225	251	2.841	2.263	-
E4.42.237.R.0	H4.42.237.R.0	-	237	264	2.865	2.275	-
E4.42.25.R.0	H4.42.25.R.0	R4.42.25.R.0	250	276	2.979	2.332	4.250
E4.42.262.R.0	H4.42.262.R.0	-	262	289	3.048	2.367	-
E4.42.28.R.0	H4.42.28.R.0	-	275	301	3.108	2.397	-
E4.42.29.R.0	H4.42.29.R.0	-	287	314	3.136	2.411	-
E4.42.30.R.0	H4.42.30.R.0	R4.42.30.R.0	300	326	3.2433	2.464	4.890
E4.42.312.R.0	H4.42.312.R.0	-	312	339	3.262	2.474	-
E4.42.325.R.0	H4.42.325.R.0	-	325	351	3.348	2.517	-
E4.42.337.R.0	H4.42.337.R.0	-	337	364	3.399	2.542	-
E4.42.350.R.0	H4.42.350.R.0	-	350	376	3.588	2.637	-
E4.42.362.R.0	H4.42.362.R.0	-	362	389	3.669	2.677	-
E4.42.375.R.0	H4.42.375.R.0	-	375	402	3.730	2.708	-
E4.42.387.R.0	H4.42.387.R.0	-	387	414	3.786	2.736	-
E4.42.400.R.0	H4.42.400.R.0	-	400	426	3.840	2.763	-

Available bending radii R (mm) 075* | 100* | 115* | 125 | 150 | 160 | 175 | 200 | 250 | 300 | 350 *Radius not available for e-tubes

Supplement Part No. with required radius (R). Examples:

E4.42.30.300.0 = e-chain® with inner width Bi 300 mm, radius R 300 mm, colour black

H4.42.30.300.0 = e-chain® with crossbars every 2nd link, inner width Bi 300 mm, radius R 300 mm, colour black

R4.42.30.300.0 = e-tube fully enclosed with inner width Bi 300 mm, radius R 300 mm, colour black

E4.1 Series E4.42 | Dimensions

Unsupported applications | Short travels

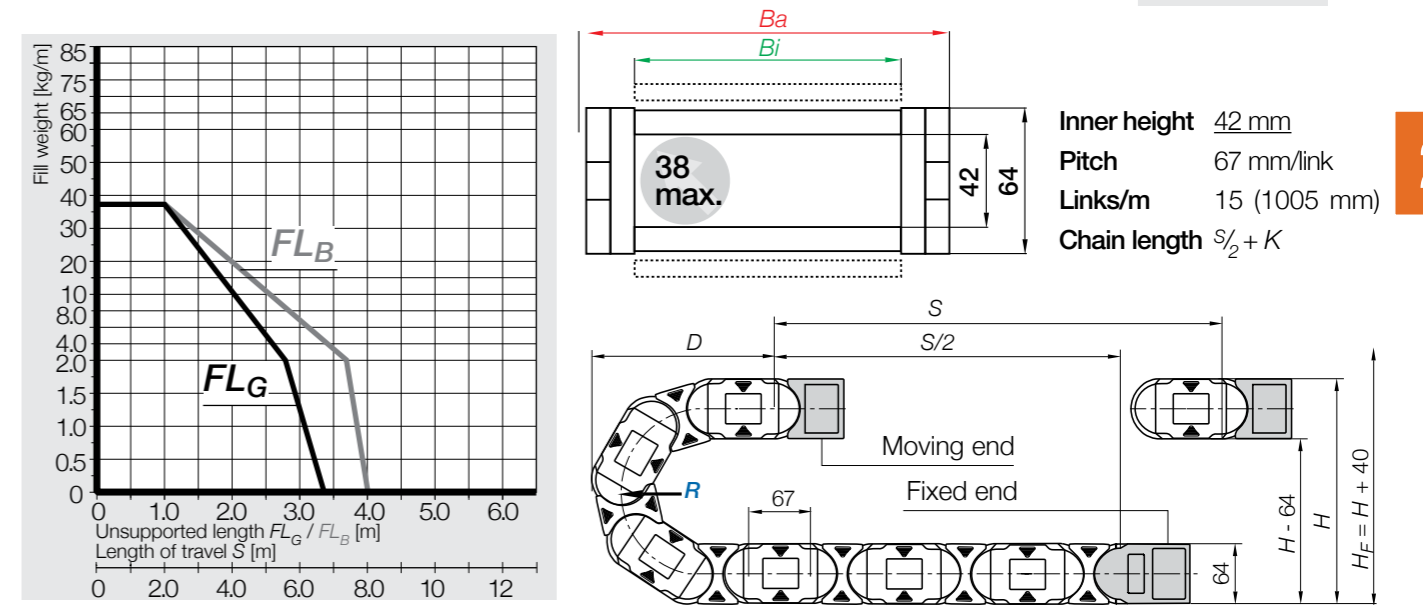

Pitch = 67 mm/link Links/m = 15 (1005 mm) Chain length = S/2 + K

R	075*	100*	115*	112	150	160	175	200	250	300	350
H ₀₋₂₅	214	264	294	314	364	384	414	464	564	664	764
D	208	233	248	258	283	293	308	333	383	433	483
K	370	450	500	530	610	640	685	765	920	1080	1235

The required clearance height: H_F = H + 40 mm (with 3.0 kg/m fill weight) *Radius not available for e-tubes

Gliding applications | Long travels from 12 m to max. 300 m

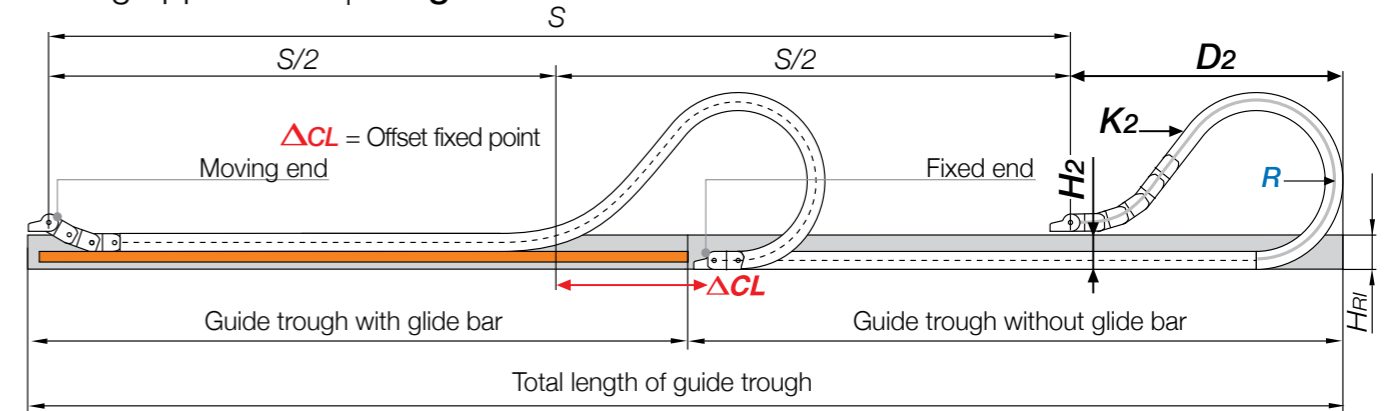

R	075*	100*	115*	112	150	160	175	200	250	300	350
H ₂	150	200	230	186	186	186	186	186	186	186	186
D ₂ ⁺²⁵	174	199	435	475	570	623	670	780	1030	1150	1500
K ₂	370	450	500	530	610	640	685	765	920	1080	1235
ΔCL	-	-	200	230	300	380	380	460	660	730	1030

*Radius not available for e-tubes

E4.1 | Series E4.42 | Accessories

KMA mounting brackets | Attachment on all sides | pivoting | locking

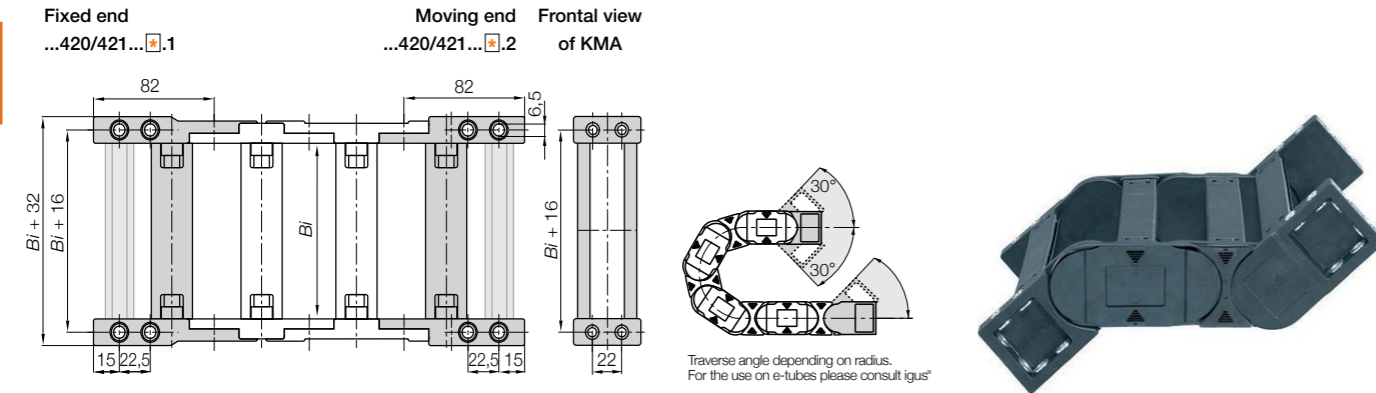

KMA pivoting | Recommended for unsupported and gliding applications | **Standard KMA locking** | Recommended for vertical hanging and standing applications

Width Index	Part No. full set KMA Pivoting	Part No. full set KMA Locking	Bi (mm)	Width Index	Part No. full set KMA Pivoting	Part No. full set KMA Locking	Bi (mm)
05.	E4. R4. 420.05. 12.C	E4. R4. 421.05. 12.C	50	212.	E4. - 420.212. 12.C	E4. - 421.212. 12.C	212
06.	E4. - 420.06. 12.C	E4. - 421.06. 12.C	68	23.	E4. - 420.23. 12.C	E4. - 421.23. 12.C	225
07.	E4. R4. 420.07. 12.C	E4. R4. 421.07. 12.C	75	237.	E4. - 420.237. 12.C	E4. - 421.237. 12.C	237
087.	E4. R4. 420.087. 12.C	E4. R4. 421.087. 12.C	87	25.	E4. R4. 420.25. 12.C	E4. R4. 421.25. 12.C	250
09.	E4. - 420.097. 12.C	E4. - 421.097. 12.C	97	262.	E4. - 420.262. 12.C	E4. - 421.262. 12.C	262
10.	E4. R4. 420.10. 12.C	E4. R4. 421.10. 12.C	100	28.	E4. - 420.28. 12.C	E4. - 421.28. 12.C	275
11.	E4. R4. 420.11. 12.C	E4. - 421.11. 12.C	108	29.	E4. - 420.29. 12.C	E4. - 421.29. 12.C	287
112.	E4. - 420.112. 12.C	E4. - 421.112. 12.C	120	30.	E4. R4. 420.30. 12.C	E4. R4. 421.30. 12.C	300
12.	E4. R4. 420.12. 12.C	E4. R4. 421.12. 12.C	125	312.	E4. - 420.312. 12.C	E4. - 421.312. 12.C	312
137.	E4. - 420.137. 12.C	E4. R4. 421.137. 12.C	137	325.	E4. - 420.325. 12.C	E4. - 421.325. 12.C	325
15.	E4. R4. 420.162. 12.C	E4. R4. 421.15. 12.C	150	337.	E4. - 420.337. 12.C	E4. - 421.337. 12.C	337
162.	E4. - 420.162. 12.C	E4. - 421.162. 12.C	162	350.	E4. - 420.350. 12.C	E4. - 421.350. 12.C	350
17.	E4.** R4. 420.17. 12.C	E4. - 421.17. 12.C	168	362.	E4. - 420.362. 12.C	E4. - 421.362. 12.C	362
18.	E4.** - 420.18. 12.C	E4. - 421.18. 12.C	175	375.	E4. - 420.375. 12.C	E4. - 421.375. 12.C	375
187.	E4.** - 420.187. 12.C	E4. - 421.187. 12.C	187	387.	E4. - 420.387. 12.C	E4. - 421.387. 12.C	387
20.	E4.** R4. 420.20. 12.C	E4. - 421.20. 12.C	200	400.	E4. - 420.400. 12.C	E4. - 421.400. 12.C	400

Note ☒: The Part No. depends on an even or odd number of links. Please insert: Index 1 (for odd) or 2 (for even).

The E4.1 may end with either an inner or an outer side link. An outer side link always forms the first e-chain® link at the moving end.



E4.1 | Series E4.42 | Accessories

Interior separation | New generation

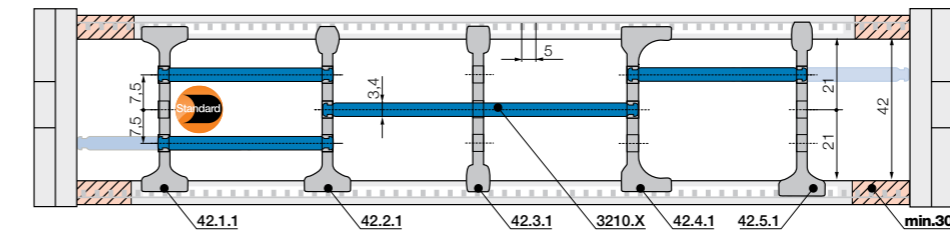

Note e-tube: Please observe a lateral spacing of 30 mm to the side links. As standard separators are assembled every 2nd e-chain® link.

Diagram	Part No.	Description	Application
	42.1	Standard separator, wide base	Standard - for any application
	42.1.1	Assembled	Separator with a wide base for maximum locking strength and safe standing in e-chains® and e-tubes.
	42.2	Standard separator, QuickLock crossbar	For even faster installation
	42.2.1	Assembled	Separator for igus® QuickLock crossbar 385.X.Q. Firm hold to one side with a wide base, narrow on opposed side for easy cable assembly. For e-tubes also.
	42.3	Standard separator, narrow base	For many thin cables
	42.3.1	Assembled	Separator with a narrow base for a large number of thin cables side by side. Saves space in e-chains® and e-tubes. Also available for QuickLock crossbars.
	42.4	Separator, asymmetrical	For side-mounted applications
	42.4.1	Assembled	Asymmetrical separator, for defined distance. No additional spacers necessary for e-chains® and e-tubes.
	42.5	Notch separator for notch crossbar	Locks safely in 5 mm increments
	42.5.1	Assembled	Notch separator for exact positioning in e-chains®. Recommended for side-mounted applications.
	3200.X	Full-width shelf, lockable	Horizontal separation
	3210.X	Assembled	Shelf locks safely into separators on both ends, fixed width possible. Separators can be moved freely over the shelf in horizontal direction. Can be arranged at 3 different heights.

Lockable Full-width shelves

Width X (mm)	Unassembled	Assembled	Width X (mm)	Unassembled	Assembled	Width X (mm)	Unassembled	Assembled
050	3200.050	3210.050	125	3200.125	3210.125	225	3200.225	3210.225
075	3200.075	3210.075	150	3200.150	3210.150	250	3200.250	3210.250
100	3200.100	3210.100	175	3200.175	3210.175			
115	3200.115	3210.115	200	3200.200	3210.200			

Interior separation | New generation

- Virtually unlimited side-by-side attachment for high fill weights necessitate extremely wide e-chains® (up to 3000 mm)
- The unsupported length FL_G max. can be increased when fill weights are required

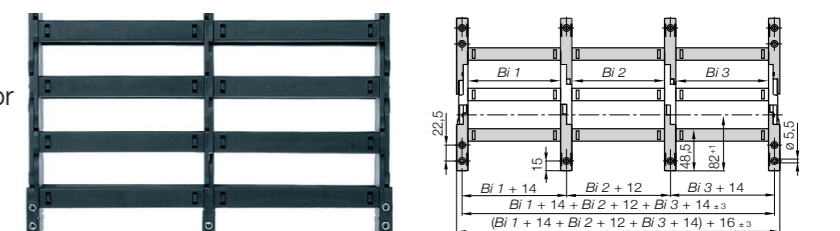

E4 | Series 14240 | Large Economical

62

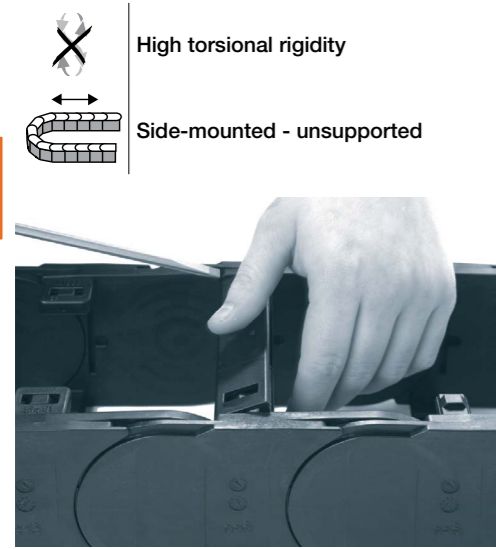

- 1 Crossbars on E-Chains® are removable along both radii
- 2 Wide, rounded plastic crossbars - cable friendly
- 3 Optimum ratio of inner height to outer height
- 4 Lateral glide surfaces for side-mounted operation
- 5 Integrated strain relief possible
- 6 Locking or pivoting mounting brackets available
- 7 KMA mounting brackets with attachment points on all sides
- 8 New stronger version with "tongue-and-groove-design"
- 9 Numerous interior separation possibilities
- 10 E-Chains® also available with reverse bending radius "RBR"

Opening E-Chains®: Remove crossbars and clips - Insert screwdriver into the slot, push down, release by lever action

	<p>When to use the Series 14240:</p> <ul style="list-style-type: none"> • For achieving simple, economical solutions • For achieving the ideal ratio between internal and external dimensions
	<p>When not to use it:</p> <ul style="list-style-type: none"> • If long side-mounted, unsupported length is required • If an increased inner height is required use Series 15050

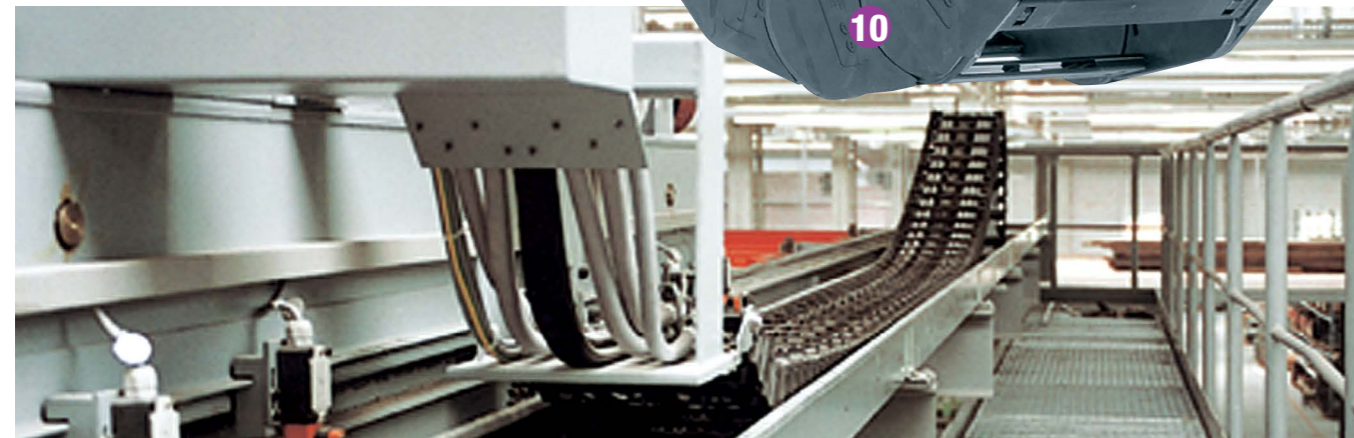
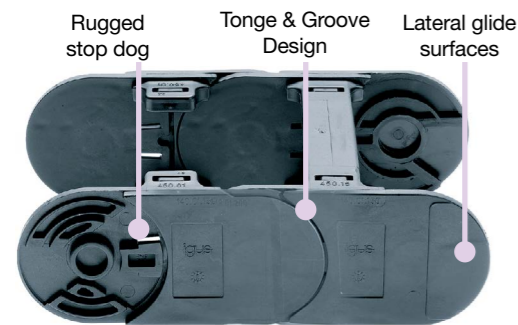

E4 | Series 14240 | Dimensions and Technical Data

Unsupported length
 FLG = with straight upper run
 FLB = with permitted sag

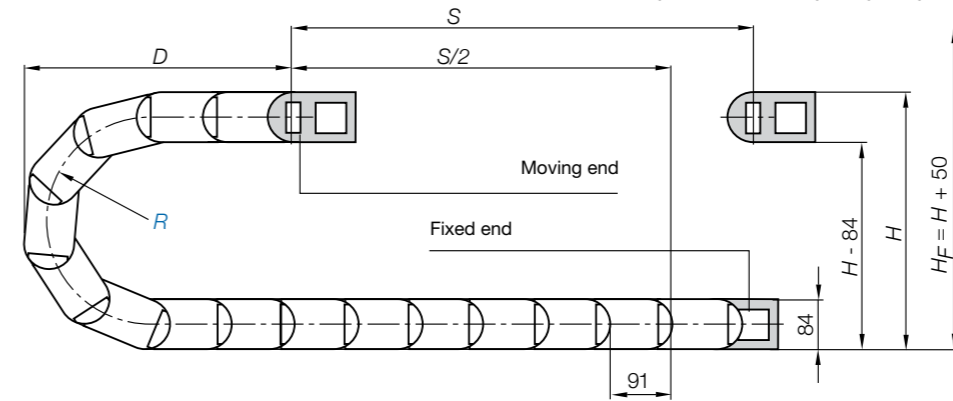
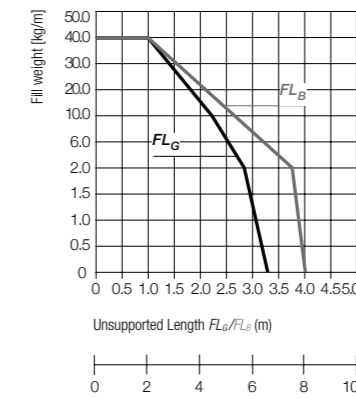
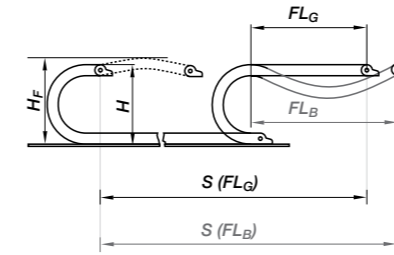

Other installation methods
 Vertical, hanging ≤ 80 m
 Vertical, standing ≤ 6 m
 Side mounted, un supp. ≤ 2 m
Short travels - unsupported
 Unsupported E-Chains® feature positive camber over short travels. This must be accounted for when specifying the clearance height HF.

- S = Length of travel
- R = Bending radius
- H = Nominal clearance height
- H_F = Required clearance height
- H_R = Trough inner height
- D = Overlength E-Chain® radius in final position
- K = $\pi \cdot R$ + "safety"
- D₂ = Over length - long travels, gliding
- K₂ = *Further add-on
- H₂ = *Mounting height
- *if the mounting bracket location is set lower

Pitch = 91 mm/link Links/m = 11 (1001 mm) Chain length = $S/2 + K$

R	135	150	175	200	250	300	400	500
H _F ⁰ ₊₂₅	354	384	434	484	584	684	884	1084
D	314	329	354	379	429	479	579	679
K	610	655	735	815	970	1125	1440	1755
D ₂ ⁺²⁵	390	450	550	710	920	1120	1530	1850
K ₂	728	819	1001	1274	1638	1911	2548	3185
H ₂	266	266	266	266	266	266	266	266

Long travel lengths from 10 m to max. 150 m

Chain length = $S/2 + K_2$

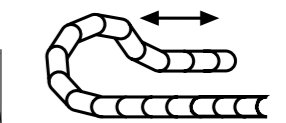
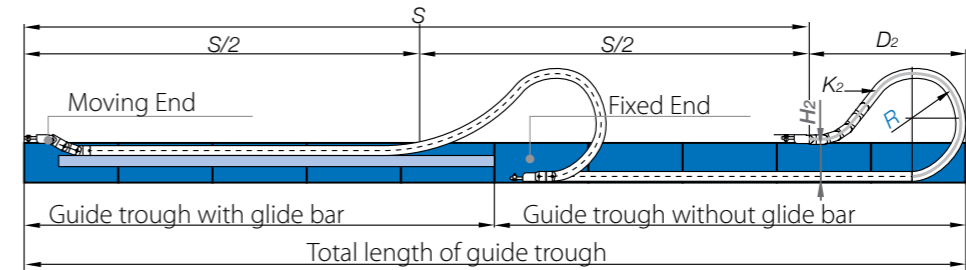

Gliding, long travel applications (max. 150 m)
 In this case the E-Chain® upper run will be introduced in a guide trough on the lower run. We recommend for long travel applications to contact Treotham Automation.

In case of travels between 4 and 10m we recommend a longer unsupported length.

Speed / acceleration FL _G	max. 20 [m/s] / max. 200 [m/s ²]
Speed / acceleration FL _B	max. 3 [m/s] / max. 6 [m/s ²]
Gliding speed / acceleration (maximum)	max. 10 [m/s] / max. 50 [m/s ²]
Material - permitted temperature °C	igumid G / -40° up to +120° C
Flammability class, igumid G	VDE 0304 IIC UL94 HB

E4 | Series 14240 | Product Range

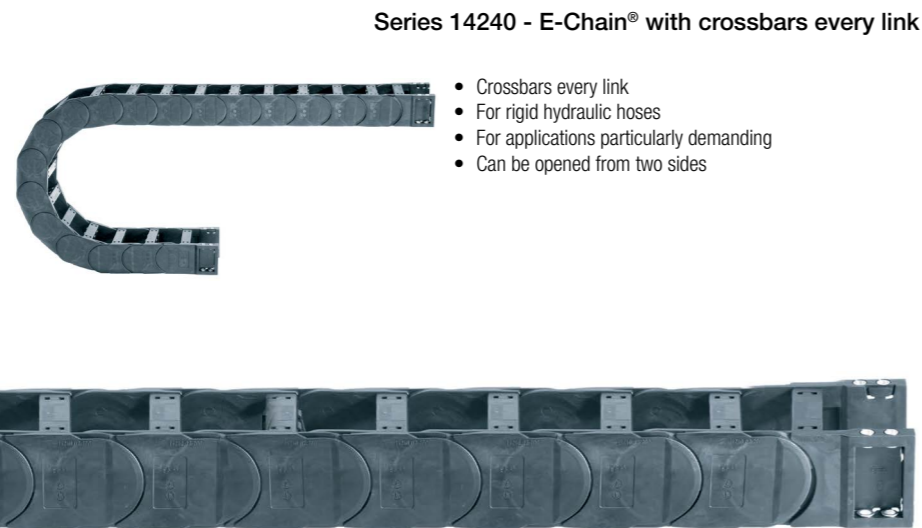
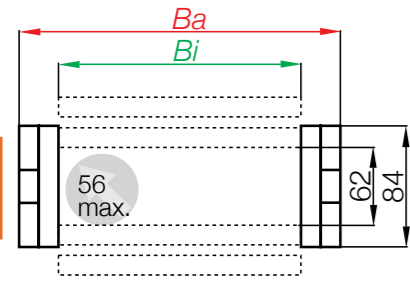

- Crossbars every link
- For rigid hydraulic hoses
- For applications particularly demanding
- Can be opened from two sides

Part No.structure
14240.10.250.0



Series 14240 - E-Chain with crossbars every link

E-Chain Part No	Bi[mm]	Ba[mm]	E-Chain Part No	Bi[mm]	Ba[mm]
14240.05.	50	76	14240.23.	225	251
14240.06.	68	94	14240.237.	237	264
14240.07.	75	101	14240.25.	250	276
14240.087.	87	114	14240.262.	262	289
14240.10.	100	126	14240.28.	275	301
14240.11.	108	134	14240.29.	287	314
14240.112.	112	139	14240.30.	300	326
14240.12.	125	151	14240.312.	312	339
14240.137.	137	164	14240.325.	325	351
14240.15.	150	176	14240.337.	337	364
14240.162.	162	189	14240.350.	350	376
14240.17.	168	194	14240.362.	362	389
14240.18.	175	201	14240.375.	375	401
14240.187.	187w	214	14240.387.	387	414
14240.20.	200	226	14240.400.	400	426
14240.212.	212	239			

Available bending radius R [mm] [135](#) [150](#) [175](#) [200](#) [250](#) [300](#) [400](#) [500](#)
 Supplement Part No. with required radius. Example: 14240.12. [250](#).0

Extender Crossbars also available for series E2/000 • E4.56 • E4.80



- Extender crossbars - careful guide of hoses applications**
- Suitable for hoses with a maximum outer diameter of 115 mm
 - Gliding operation with crossbars assembled along the outer radius and a special guide trough
 - Gliding operation not guaranteed with crossbars assembled along the inner radius
 - The extender crossbar can either be attached to the side links directly or can be used in combination with two stranded snap-open crossbars

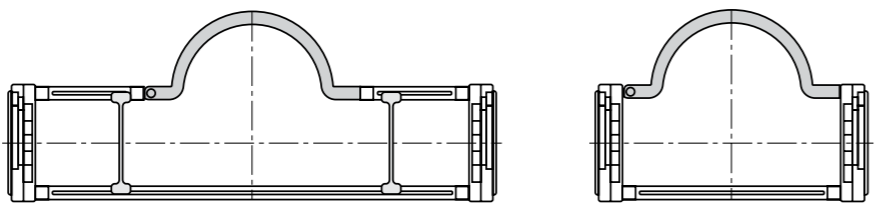

E4 | Series 14240 | Accessories | Interior Separation

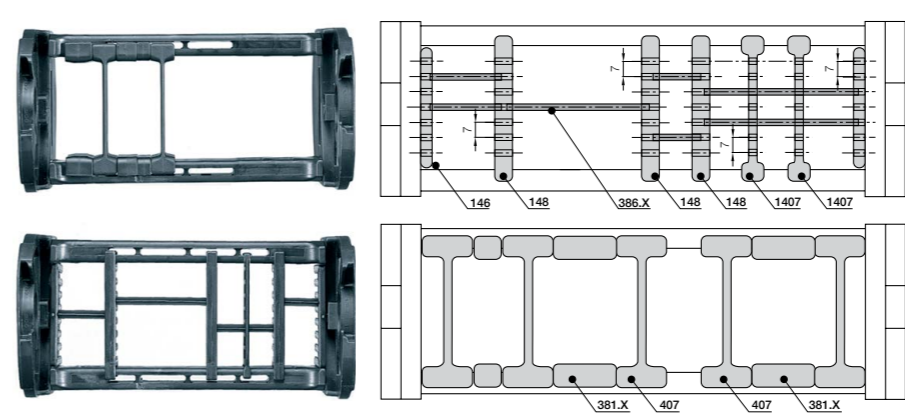

Option 1: Vertical Separators and Spacers
 Vertical separators are used if a vertical subdivision of the E-Chain interior is required - By standard vertical separators are assembled on every second E-Chain link.

Option 2: Shelves
 For applications involving many cables with different diameters. Shelves can be arranged on different levels throughout the E-Chain.

*For complete details of option 1 and 2 interior shelving systems. Please contact your nearest Treotham Automation office.

E4/light | Series 14240 | Accessories | Mounting Brackets

Pivoting

- Recommended for unsupported and gliding applications

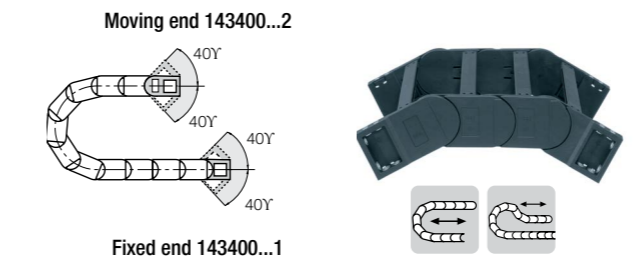

Locking

- Recommended for vertical hanging / standing applications

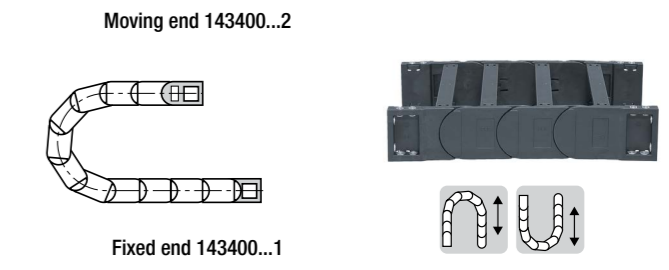

Part No.structure (Pivoting)

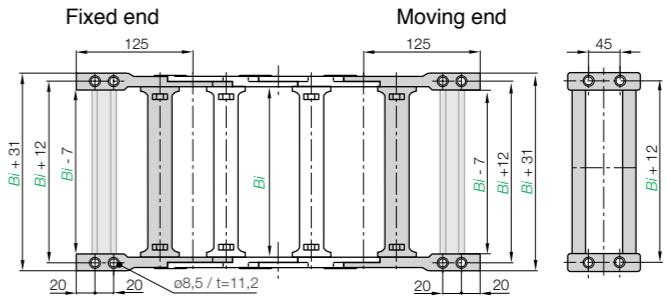
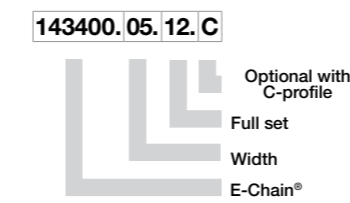

Part No.structure (Locking)

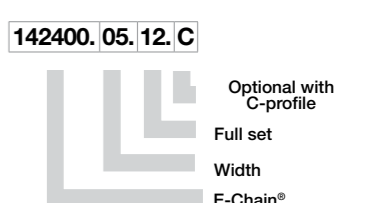

Bracket Part No. full set	Width	Full Set	C-profile option	Bi [mm]
143400	05.	.12	C	50
143400	06.	.12	C	68
143400	07.	.12	C	75
143400	087.	.12	C	87
143400	10.	.12	C	100
143400	11.	.12	C	108
143400	112.	.12	C	112
143400	12.	.12	C	125
143400	137.	.12	C	137
143400	15.	.12	C	150
143400	162.	.12	C	162
143400	17.	.12	C	168
143400	18.	.12	C	175
143400	187.	.12	C	187
143400	20.	.12	C	200

Bracket Part No. full set	Width	Full Set	C-profile option	Bi [mm]
143400	23.	.12	C	225
143400	237.	.12	C	237
143400	25.	.12	C	250
143400	262.	.12	C	262
143400	28.	.12	C	275
143400	29.	.12	C	287
143400	30.	.12	C	300
143400	312.	.12	C	312
143400	325.	.12	C	325
143400	337.	.12	C	337
143400	350.	.12	C	350
143400	362.	.12	C	362
143400	375.	.12	C	375
143400	387.	.12	C	387
143400	400.	.12	C	400

E4.1 | Series E4.56 | Extra Heavy Duty



Low noise version available with special rubber pads design

2

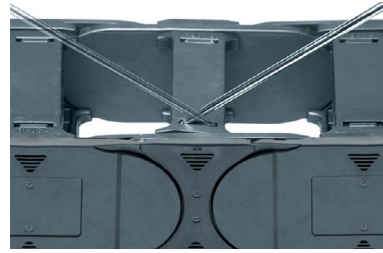

Opening E-Chains: Remove crossbars and clips - Insert screwdriver into the slot, push down, release by lever action

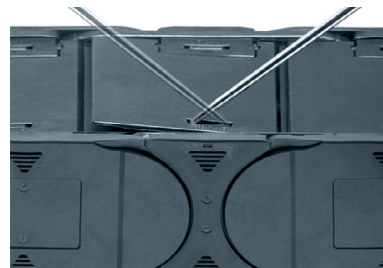

Remove lids/bottoms (E-Tubes) - Insert screwdriver into the slot, release by lever action

- 1 Straight run through inner/outer-link design
- 2 Low-noise operation through integrated brake in the radial stop dog system By the undercut design, very high stiffening and carrying capacity when shear forces are at work
- 3 15% more tensile strength (compared to the best old E4 series), better unsupported length through improved stop dog system and vertical radial stops
- 4 Crossbar available for faster assembly/disassembly - 450.X.Q
- 5 Shelving program with a wide range of options - interior separation for a quicker cable insertion available - T563
- 6 Version NC "without pretension" simply by turning outer links without rework possible
- 7 Crossbars are removable along both radii
- 8 Hinged snap-open removable lids along outer radius of E-Tube
- 9 Wide, rounded plastic crossbars - cable friendly

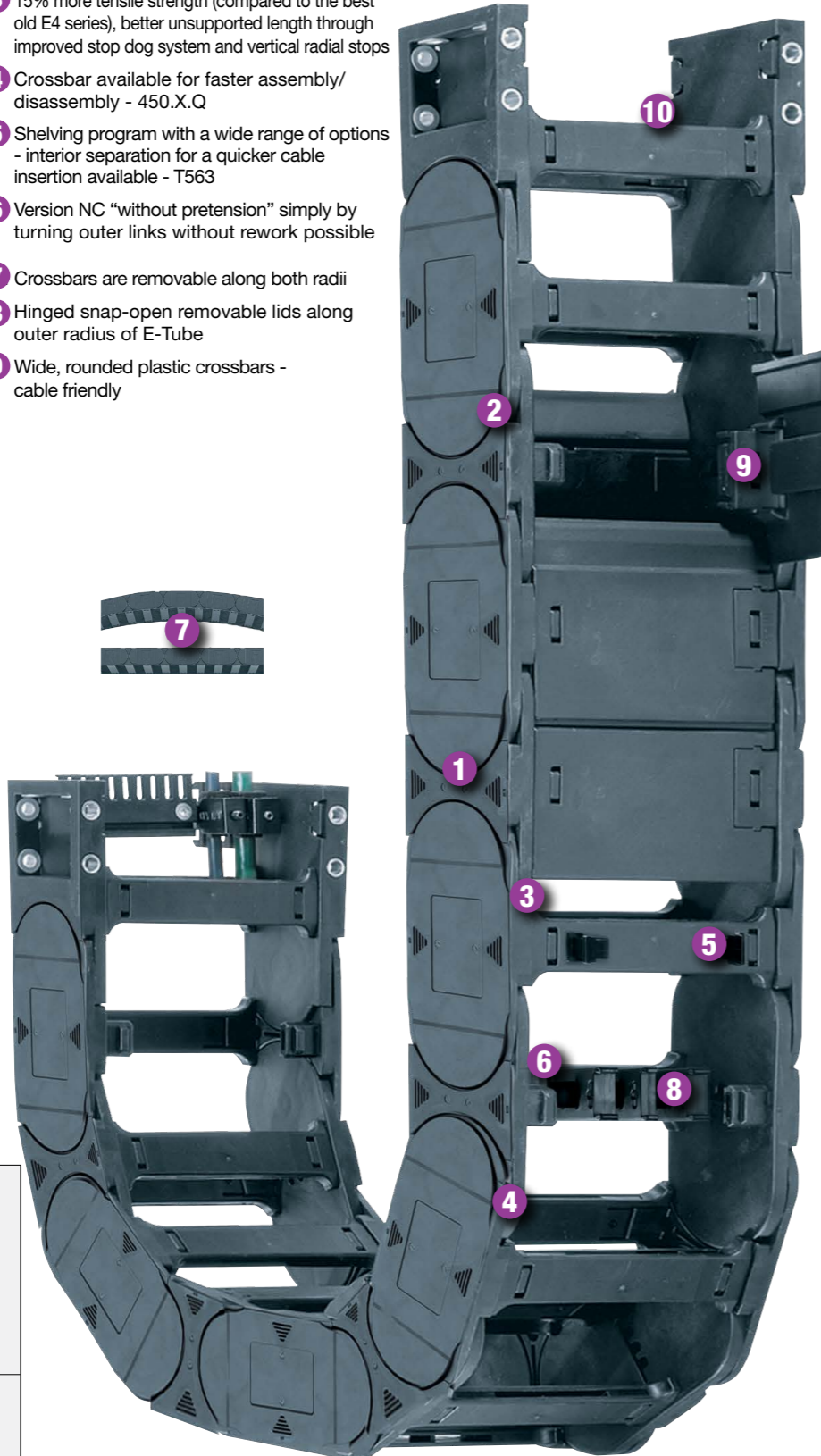

	When to use the Series E4.56/H4.56/R4.56:
	<ul style="list-style-type: none"> • If a low-noise version is required • At very high speeds and/or accelerations • For long travels • For high additional loads
	When not to use it:
	<ul style="list-style-type: none"> • If the stability of a "light" version with thinner side parts is required due to cost - and space reasons use Series 14240, page 188

Series E4.56 | Installation Dimensions and Technical Data

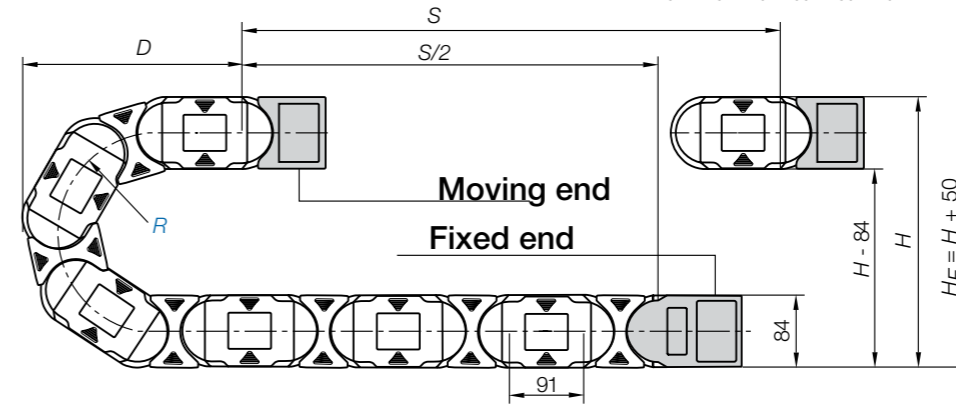
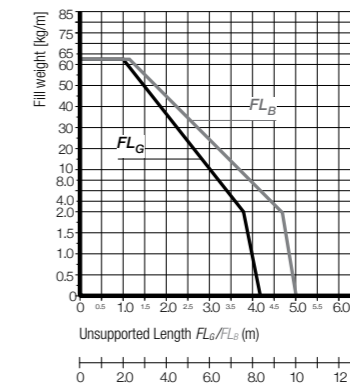
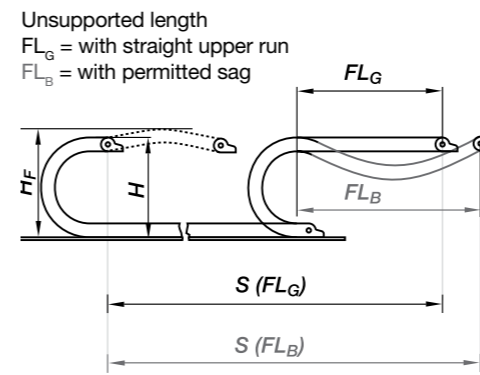

Other installation methods
 Vertical, hanging ≤ 100 m
 Vertical, standing ≤ 6 m
 Side mounted, un supp. ≤ 2.5 m

Short travels - unsupported
 Unsupported E-Chains® feature positive camber over short travels. This must be accounted for when specifying the clearance height HF.

- S = Length of travel
 - R = Bending radius
 - H = Nominal clearance height
 - H_F = Required clearance height
 - H_{RI} = Trough inner height
 - D = Overlength E-Chain® radius in final position
 - K = π • R + "safety"
 - D₂ = Over length - long travels, gliding
 - K₂ = *Further add-on
 - H₂ = *Mounting height
- *if the mounting bracket location is set lower

Pitch = 91 mm/link Links/m = 11 (1001 mm) Chain length = $\frac{S}{2} + K$

R	135	150	175	200	240	250	300	350	400	450	500
H ₊₂₅ ⁰	354	384	434	484	564	584	684	784	884	984	1084
D	314	329	354	379	419	429	479	529	579	629	679
K	610	655	735	815	940	970	1125	1285	1440	1600	1755
D ₊₂₅	268	450	580	710	900	980	1180	1440	1530	1700	1850
K ₂	610	819	1092	1274	1547	1638	2002	2275	2548	2912	3276
H ₂	270	266	266	266	266	266	266	266	266	266	266

Long travel lengths from 10 m to max. 400 m

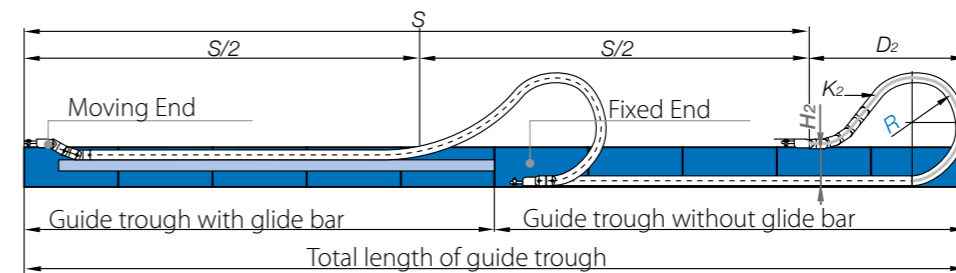

In case of travels between 4 and 10m we recommend a longer unsupported length.

Chain length = $\frac{S}{2} + K_2$
Gliding, long travel applications (max. 400m)
 In this case the E-Chain® upper run will be introduced in a guide trough on the lower run. We recommend for long travel applications to contact Treotham Automation.

Speed / acceleration FL _G	max. 20 [m/s] / max. 200 [m/s ²]
Speed / acceleration FL _B	max. 3 [m/s] / max. 6 [m/s ²]
Gliding speed / acceleration (maximum)	max. 10 [m/s] / max. 50 [m/s ²]
Material - permitted temperature °C	igumid G / -40° up to +120° C
Flammability class, igumid G	VDE 0304 IIC UL94 HB

2

Series E4.56 - E-Chain® with crossbars every link

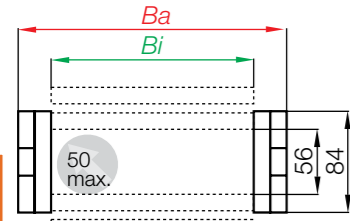

- Crossbars every link
- For rigid hydraulic hoses
- For applications particularly demanding
- Can be opened from two sides

Part No. structure
E4.56. 13. 250. 0



Series R4.56 - Fully enclosed E-Tube

- Fully enclosed
- Excellent cable protection against dirt
- Protection against hot chips
- Lids along the entire inner radius are completely removable.
- Lids along the entire outer radius are single sided snap-open with a hinge on the other side to keep them attached to the chain or completely removable.



Series H4.56 - E-Chain® with crossbars every 2nd link

- Crossbars every 2nd link = Standard
- For nearly every situation
- Can be opened from two sides
- Easy assembly
- Stable
- Attractive price



Series E4.56 - E-Chain® with crossbars every link

For complete details of R4.56 & H4.56, please contact your nearest Treotham Automation office** Available sizes of R4.56 E-Tubes

E-Chain Part No	Bi[mm]	Ba[mm]	E-Chain Part No	Bi[mm]	Ba[mm]	E-Chain Part No	Bi[mm]	Ba[mm]
E4.56.05.	50	84	E4.56.22.	225	259	**E4.56.40.	400	434
E4.56.06.	65	99	E4.56.23.	237	272	E4.56.41.	412	447
**E4.56.07.	75	109	**E4.56.25.	250	284	E4.56.42.	425	459
E4.56.08.	87	121	E4.56.26.	262	297	E4.56.43.	437	472
**E4.56.10.	100	134	**E4.56.27.	275	309	E4.56.45.	450	484
E4.56.11.	112	147	E4.56.28.	287	322	**E4.56.46.	462	497
**E4.56.12.	125	159	**E4.56.30.	300	334	E4.56.47.	475	509
E4.56.13.	137	172	E4.56.31.	312	347	E4.56.48.	487	522
**E4.56.15.	150	184	E4.56.32.	325	359	E4.56.50.	500	534
E4.56.16.	162	197	E4.56.33.	337	372	E4.56.51.	512	547
E4.56.17.	175	209	**E4.56.35.	350	384	E4.56.52.	525	559
E4.56.18.	187	222	E4.56.36.	362	397	E4.56.53.	537	572
**E4.56.20.	200	234	E4.56.37.	375	409	E4.56.55.	550	584
E4.56.21.	212	247	E4.56.38.	387	422	E4.56.60.	600	634

Available bending radii
R [mm] 135 150 175 200 240 250 300 350 400 450 500 Supplement Part No. with required radius. Example: E4.56.12 300.0

Series E4.56 | Accessories | Interior Separation

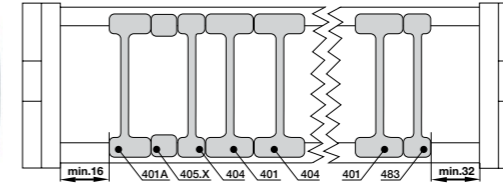

Option 1: Vertical Separators and Spacers

Vertical separators are used if a vertical subdivision of the E-Chain® interior is required - By standard vertical separators are assembled on every second E-Chain® link.

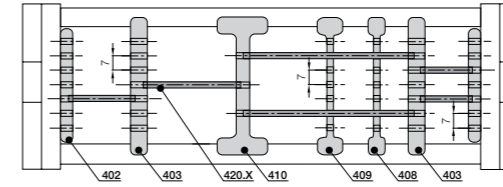
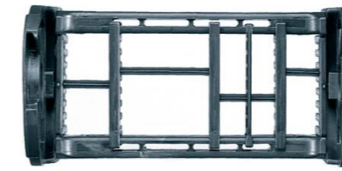

Option 2: Shelves

For applications involving many cables with different diameters. Shelves can be arranged on different levels throughout the E-Chain.

*For complete details of option 1 and 2 interior shelving systems. Please contact your nearest Treotham Automation office.

Series E4.56 | Accessories | Mounting Brackets

Pivoting

- Recommended for unsupported and gliding applications

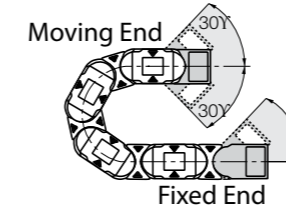

Part No. structure (Pivoting)

E4.560. 05. 1. 12. C



Locking

- Recommended for vertical hanging standing applications

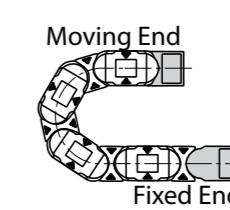

Part No. structure (Locking)

E4.561. 05. 1. 12. C

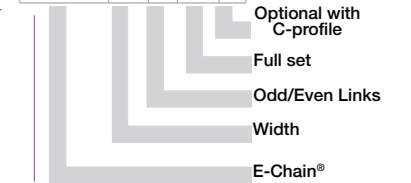

Bracket Part No. full set	Width	Odd or Even Links	Full Set	C-profile option	Bi [mm]
E4.560	E4.561	.05.	.12	C	50
E4.560	E4.561	.06.	.12	C	65
E4.560	E4.561	.07.	.12	C	75
E4.560	E4.561	.10.	.12	C	100
E4.560	E4.561	.11.	.12	C	112
E4.560	E4.561	.12.	.12	C	125
E4.560	E4.561	.13.	.12	C	137
E4.560	E4.561	.15.	.12	C	150
E4.560	E4.561	.16.	.12	C	162
E4.560	E4.561	.17.	.12	C	175
E4.560	E4.561	.18.	.12	C	187
E4.560	E4.561	.20.	.12	C	200
E4.560	E4.561	.21.	.12	C	212
E4.560	E4.561	.22.	.12	C	225
E4.560	E4.561	.23.	.12	C	237
E4.560	E4.561	.25.	.12	C	250
E4.560	E4.561	.26.	.12	C	262
E4.560	E4.561	.27.	.12	C	275
E4.560	E4.561	.28.	.12	C	287
E4.560	E4.561	.30.	.12	C	300
E4.560	E4.561	.31.	.12	C	312

Bracket Part No. full set	Width	Odd or Even Links	Full Set	C-profile option	Bi [mm]
E4.560	E4.561	.32.	.12	C	325
E4.560	E4.561	.33.	.12	C	337
E4.560	E4.561	.35.	.12	C	350
E4.560	E4.561	.36.	.12	C	362
E4.560	E4.561	.37.	.12	C	375
E4.560	E4.561	.38.	.12	C	387
E4.560	E4.561	.40.	.12	C	400
E4.560	E4.561	.41.	.12	C	412
E4.560	E4.561	.42.	.12	C	425
E4.560	E4.561	.43.	.12	C	437
E4.560	E4.561	.45.	.12	C	450
E4.560	E4.561	.46.	.12	C	462
E4.560	E4.561	.47.	.12	C	475
E4.560	E4.561	.48.	.12	C	487
E4.560	E4.561	.50.	.12	C	500
E4.560	E4.561	.51.	.12	C	512
E4.560	E4.561	.52.	.12	C	525
E4.560	E4.561	.53.	.12	C	537
E4.560	E4.561	.55.	.12	C	550
E4.560	E4.561	.60.	.12	C	600

E4.1 | Series E4.80 | Extra Heavy Duty



Low noise version available with special rubber pads design

2

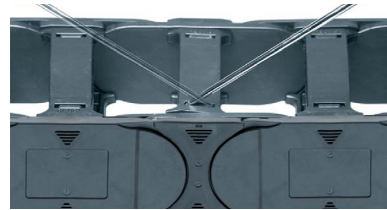

Opening E-Chains: Remove crossbars and clips - Insert screwdriver into the slot, push down, release by lever action



Remove lids/bottoms (E-Tubes) - Insert screwdriver into the slot, release by lever action

- 1 Straight run through inner/outer-link design
- 2 Low-noise operation through integrated brake in the radial stop dog system. By the undercut design, very high stiffening and carrying capacity when shear forces are at work
- 3 15% more tensile strength (compared to the best old E4 series), better unsupported length through improved stop dog system and vertical radial stops
- 4 Crossbar available for faster assembly/disassembly - 450.X.Q
- 5 Shelving program with a wide range of options - interior separation for a quicker cable insertion available - T563
- 6 Version NC "without pretension" simply by turning outer links without rework possible
- 7 Crossbars are removable along both radii
- 8 Hinged snap-open removable lids along outer radius of E-Tube
- 9 Wide, rounded plastic crossbars - cable friendly

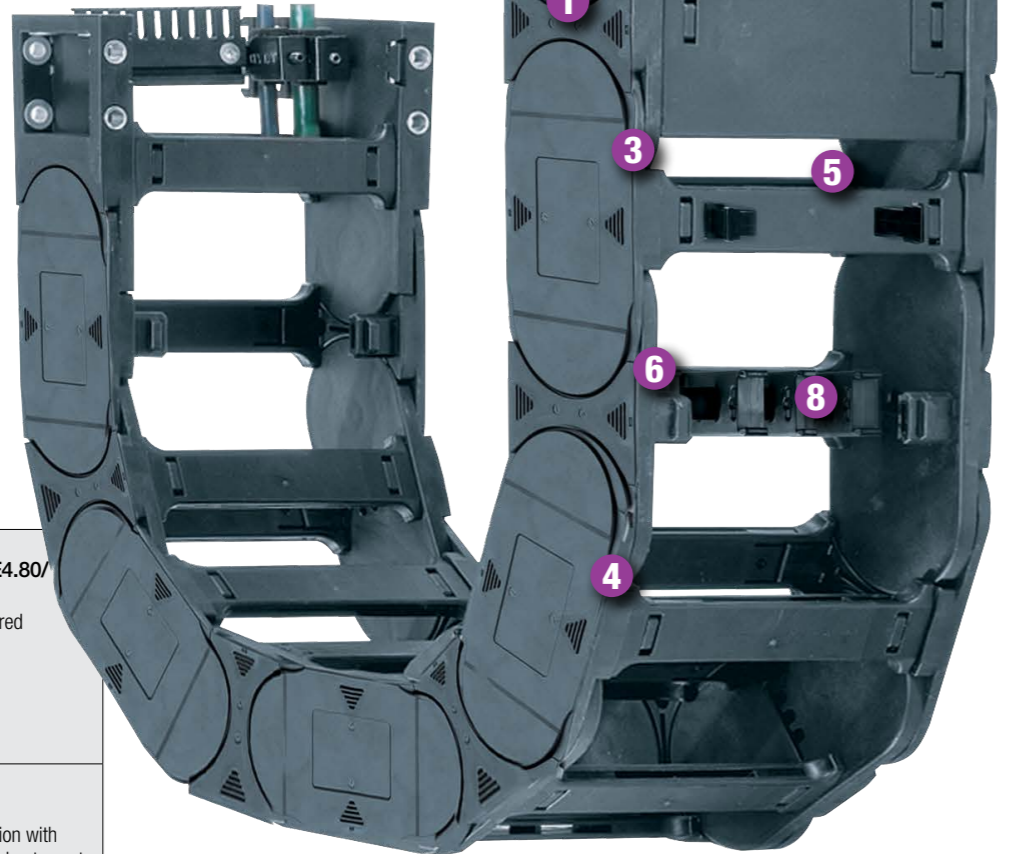

When to use the Series E4.80/H4.80/R4.80:

- If a low-noise version is required
- At very high speeds and/or accelerations
- For long travels
- For high additional loads



When not to use it:

- If the stability of a "light" version with thinner side parts is required due to cost- and space reasons use (Series 15050)

Series E4.80 | Installation Dimensions and Technical Data

Unsupported length
 FL_G = with straight upper run
 FL_B = with permitted sag

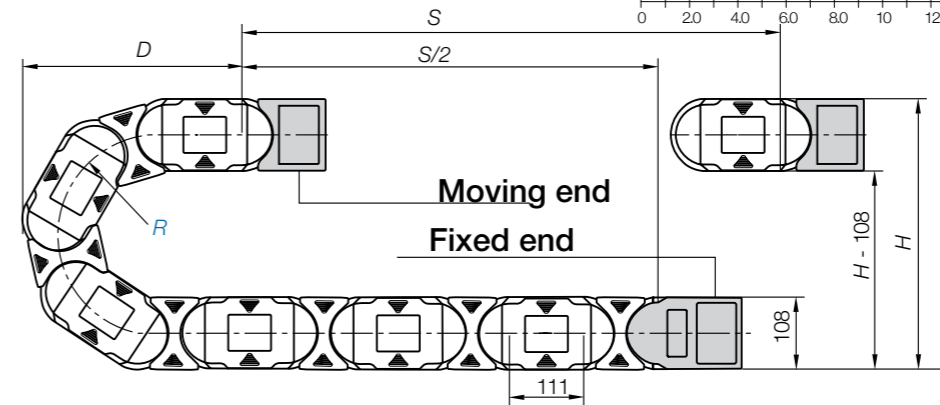
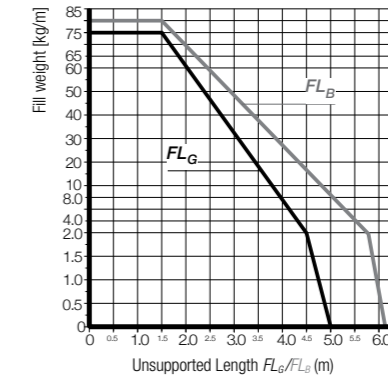
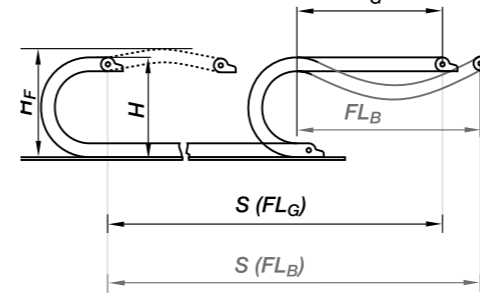

Other installation methods
 Vertical, hanging ≤ 100 m
 Vertical, standing ≤ 6 m
 Side mounted, un_supp. ≤ 2.5 m

Short travels - unsupported
 Unsupported E-Chains® feature positive camber over short travels. This must be accounted for when specifying the clearance height HF.

- S = Length of travel
- R = Bending radius
- H = Nominal clearance height
- H_F = Required clearance height
- H_{RI} = Trough inner height
- D = Overlength E-Chain® radius in final position
- K = $\pi \cdot R$ + "safety"
- D₂ = Over length - long travels, gliding
- K₂ = *Further add-on
- H₂ = *Mounting height
- *if the mounting bracket location is set lower

Pitch = 111 mm/link Links/m = 9 (999 mm) Chain length = $S/2 + K$

R	150	200	250	300	350	400	500	550	600	1000
H ₊₂₅ ⁰	408	508	608	708	808	908	1108	1208	1308	2108
D	371	421	471	521	571	621	721	771	821	1221
K	695	855	1010	1165	1325	1480	1795	1950	2110	3365
D ₊₂₅	550	800	1000	1200	1450	1600	2100	-	-	-
K ₂	890	1330	1665	2000	2330	2660	3440	-	-	-
H ₂	242	242	242	242	242	242	242	-	-	-

Long travel lengths from 10 m to max. 400 m

Chain length = $S/2 + K_2$

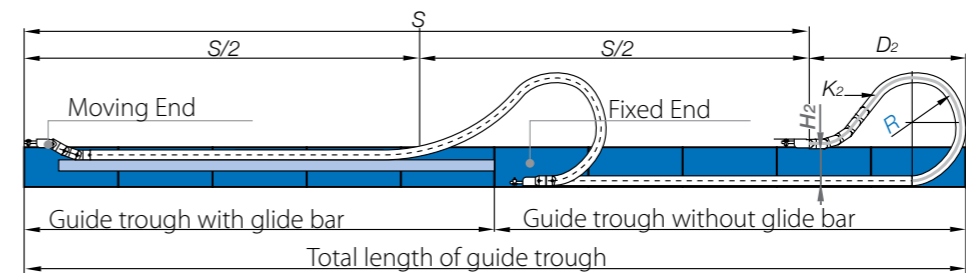

In case of travels between 4 and 10m we recommend a longer unsupported length.

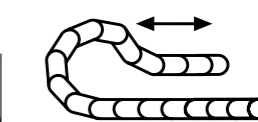

Gliding, long travel applications (max. 400m)
 In this case the E-Chain® upper run will be introduced in a guide trough on the lower run. We recommend for long travel applications to contact Treotham Automation.

Speed / acceleration FL_G	max. 20 [m/s] / max. 200 [m/s ²]
Speed / acceleration FL_B	max. 3 [m/s] / max. 6 [m/s ²]
Gliding speed / acceleration (maximum)	max. 10 [m/s] / max. 50 [m/s ²]
Material - permitted temperature °C	igumid G / -40° up to +120° C
Flammability class, igumid G	VDE 0304 IIC UL94 HB

Series E4.80 - E-Chain with crossbars every link

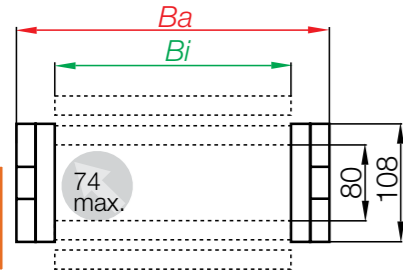

- Crossbars every link
- For rigid hydraulic hoses
- For applications particularly demanding
- Can be opened from two sides



Part No. structure

E4.80. 20. 250. 0



Series R4.80 - Fully enclosed E-Tube

- Fully enclosed
- Excellent cable protection against dirt
- Protection against hot chips
- Lids along the entire inner radius are completely removable.
- Lids along the entire outer radius are single sided snap-open with a hinge on the other side to keep them attached to the chain or completely removable.



Series H4.80 - E-Chain® with crossbars every 2nd link

- Crossbars every 2nd link = Standard
- For nearly every situation
- Can be opened from two sides
- Easy assembly
- Stable
- Attractive price



Series E4.80 - E-Chain® with crossbars every link

E-Chain Part No	Bi[mm]	Ba[mm]	E-Chain Part No	Bi[mm]	Ba[mm]	E-Chain Part No	Bi[mm]	Ba[mm]
E4.80.05.	50	100	E4.80.23.	237	288	E4.80.41.	412	463
E4.80.06.	65	115	**E4.80.25.	250	300	E4.80.42.	425	475
E4.80.07.	75	125	E4.80.26.	262	313	E4.80.43.	437	488
E4.80.10.	100	150	E4.80.27.	275	325	E4.80.45.	450	500
E4.80.11.	112	163	E4.80.28.	287	338	E4.80.46.	462	513
E4.80.12.	125	175	E4.80.30.	300	350	E4.80.47.	475	525
E4.80.13.	137	188	E4.80.31.	312	363	E4.80.48.	487	538
E4.80.15.	150	200	E4.80.32.	325	375	E4.80.50.	500	550
E4.80.16.	162	213	E4.80.33.	337	388	E4.80.51.	512	563
E4.80.17.	175	225	E4.80.35.	350	400	E4.80.52.	525	575
E4.80.18.	187	238	E4.80.36.	362	413	E4.80.53.	537	588
E4.80.20.	200	250	E4.80.37.	375	425	E4.80.55.	550	600
E4.80.21.	212	263	E4.80.38.	387	438	E4.80.60.	600	650
E4.80.22.	225	275	**E4.80.40.	400	450			

Available bending radii R [mm] 150 200 250 300 350 400 500 550 600 1000 Supplement Part No. with required radius. Example: E4.80.12 250 0

For complete details of R4.80 & H4.80, please contact your nearest Treotham Automation office. **Available sizes of R4.80 E-Tubes

Series E4.80 | Accessories | Interior Separation

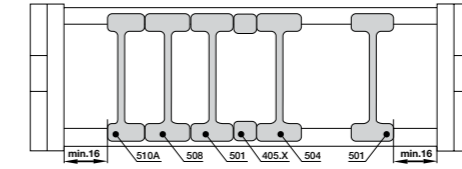
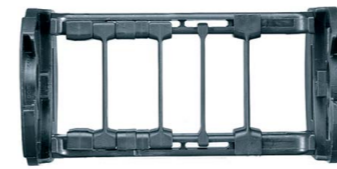

Option 1: Vertical Separators and Spacers
Vertical separators are used if a vertical subdivision of the E-Chain® interior is required. By standard, vertical separators are assembled on every second E-Chain® link.

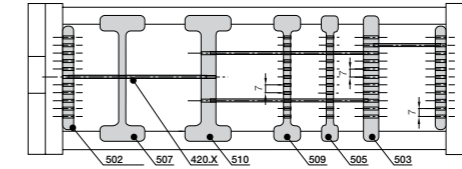
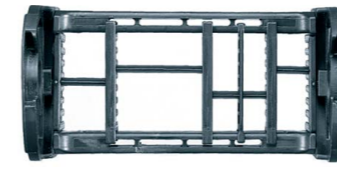

Option 2: Shelves
For applications involving many cables with different diameters. Shelves can be arranged on different levels throughout the E-Chain®.

*For complete details of option 1 and 2 interior shelving systems. Please contact your nearest Treotham Automation office.

Series E4.80 | Accessories | Mounting Brackets

Pivoting

- Recommended for unsupported and gliding applications

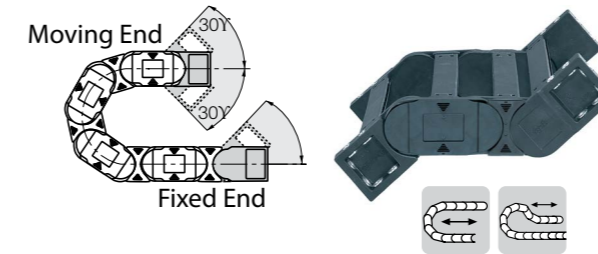

Part No. structure (Pivoting)

E4.800. 05. 1. 12. C

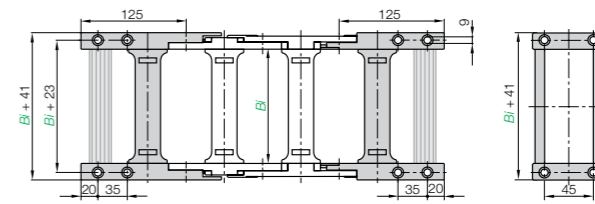
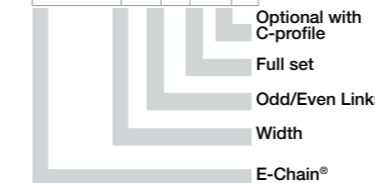

Locking

- Recommended for vertical hanging standing applications

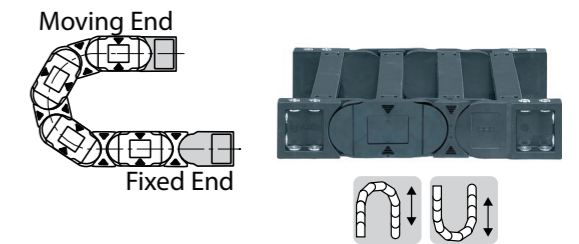

Part No. structure (Locking)

E4.801. 05. 1. 12. C

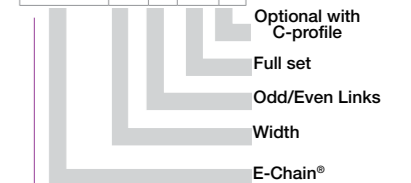

Bracket Part No. full set pivoting	locking	Width	Odd or Even Links	Full Set	C-profile option	Bi [mm]
E4.800	E4.801	.05.	<input type="checkbox"/>	.12	C	50
E4.800	E4.801	.06.	<input type="checkbox"/>	.12	C	65
E4.800	E4.801	.07.	<input type="checkbox"/>	.12	C	75
E4.800	E4.801	.10.	<input type="checkbox"/>	.12	C	100
E4.800	E4.801	.11.	<input type="checkbox"/>	.12	C	112
E4.800	E4.801	.12.	<input type="checkbox"/>	.12	C	125
E4.800	E4.801	.13.	<input type="checkbox"/>	.12	C	137
E4.800	E4.801	.15.	<input type="checkbox"/>	.12	C	150
E4.800	E4.801	.16.	<input type="checkbox"/>	.12	C	162
E4.800	E4.801	.17.	<input type="checkbox"/>	.12	C	175
E4.800	E4.801	.18.	<input type="checkbox"/>	.12	C	187
E4.800	E4.801	.20.	<input type="checkbox"/>	.12	C	200
E4.800	E4.801	.21.	<input type="checkbox"/>	.12	C	212
E4.800	E4.801	.22.	<input type="checkbox"/>	.12	C	225
E4.800	E4.801	.23.	<input type="checkbox"/>	.12	C	237
E4.800	E4.801	.25.	<input type="checkbox"/>	.12	C	250
E4.800	E4.801	.26.	<input type="checkbox"/>	.12	C	262
E4.800	E4.801	.27.	<input type="checkbox"/>	.12	C	275
E4.800	E4.801	.28.	<input type="checkbox"/>	.12	C	287
E4.800	E4.801	.30.	<input type="checkbox"/>	.12	C	300
E4.800	E4.801	.31.	<input type="checkbox"/>	.12	C	312

Bracket Part No. full set pivoting	locking	Width	Odd or Even Links	Full Set	C-profile option	Bi [mm]
E4.800	E4.801	.32.	<input type="checkbox"/>	.12	C	325
E4.800	E4.801	.33.	<input type="checkbox"/>	.12	C	337
E4.800	E4.801	.35.	<input type="checkbox"/>	.12	C	350
E4.800	E4.801	.36.	<input type="checkbox"/>	.12	C	362
E4.800	E4.801	.37.	<input type="checkbox"/>	.12	C	375
E4.800	E4.801	.38.	<input type="checkbox"/>	.12	C	387
E4.800	E4.801	.40.	<input type="checkbox"/>	.12	C	400
E4.800	E4.801	.41.	<input type="checkbox"/>	.12	C	412
E4.800	E4.801	.42.	<input type="checkbox"/>	.12	C	425
E4.800	E4.801	.43.	<input type="checkbox"/>	.12	C	437
E4.800	E4.801	.45.	<input type="checkbox"/>	.12	C	450
E4.800	E4.801	.46.	<input type="checkbox"/>	.12	C	462
E4.800	E4.801	.47.	<input type="checkbox"/>	.12	C	475
E4.800	E4.801	.48.	<input type="checkbox"/>	.12	C	487
E4.800	E4.801	.50.	<input type="checkbox"/>	.12	C	500
E4.800	E4.801	.51.	<input type="checkbox"/>	.12	C	512
E4.800	E4.801	.52.	<input type="checkbox"/>	.12	C	525
E4.800	E4.801	.53.	<input type="checkbox"/>	.12	C	537
E4.800	E4.801	.55.	<input type="checkbox"/>	.12	C	550
E4.800	E4.801	.60.	<input type="checkbox"/>	.12	C	600

Guide Troughs | Long travels with Guide Troughs

2

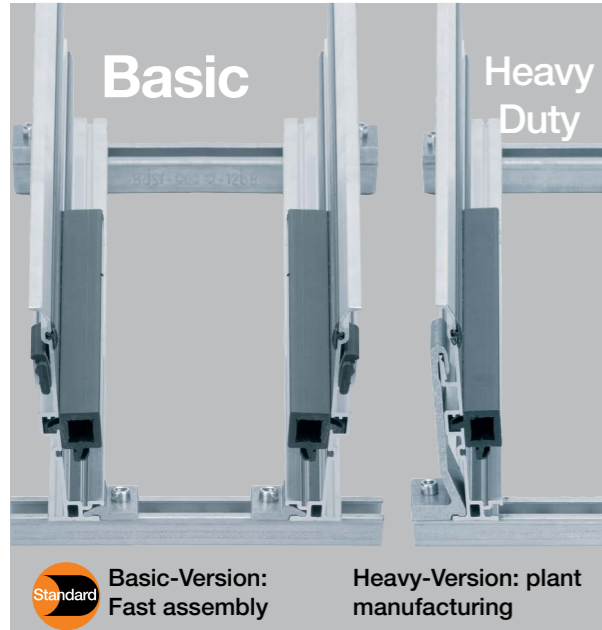

AL Aluminium "SuperTrough" - The igus® standard guide trough

- Very simple, modular assembly
- Side-mounted glide strips for wear protection in high-speed
- Corrosion resistant, seawater resistant aluminium profile
- Flexible assembly - Fastening on substructure independent of profile lengths and butt joints
- Interface connector - Plastic with snap-in connection
- Plastic glide bar made of PE
- Bottom clamp can be mounted -inside or outside- directly on the bottom or on the c-profile
- Glide strips and silencer profile for the minimization of the noise level
- Heavy duty brackets for safe connection also for rough applications
- C-profile for the fixation of the bottom clamp or heavy duty brackets

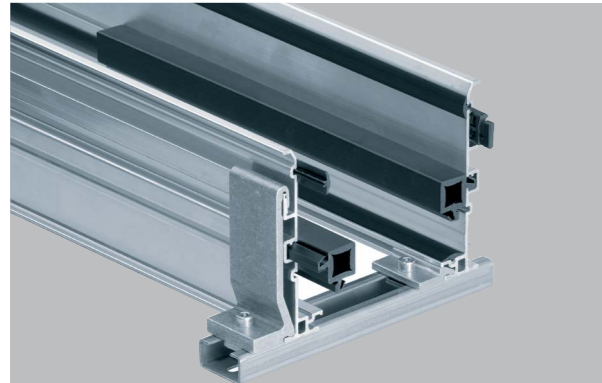

ST Steel guide trough - very stable and rugged for heavy duty applications

- Easy assembly with installation set
- Big range, two piece design, adjustable to EChain® width
- Available in galvanized steel and stainless steel
- Glide bar made of PE

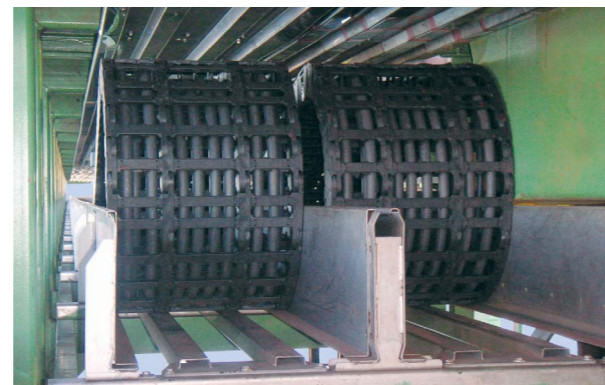

Steel Guide Trough System on a ship loader for coal un-loading, travel 105m, speed 240m/min, load 53kg/m

Guide Troughs | Long travels with Guide Troughs

2

igus® guide troughs

Guide troughs are used for long travels, (travels from 5 to 12 m) and greater, depending on the E-Chain® type. They allow to continue smooth, low-friction operation in these long-travel situations. If the E-Chains® are installed in the center of the travel ("center-mounted"), they glide on themselves for half the travel. For the other half, we recommend glide bars, which are assembled in the trough and on which the E-Chains® glide. igus® guide troughs are available from stock with these highly abrasion-resistant polymer glide bars, which perform well with igus® E-Chains® regarding noise, abrasion and friction.

Trough type

igus® offers guide troughs made of corrosion-resistant aluminum, steel, stainless steel, as well as tubes and insert troughs (with steel side plates). The trough type to be used depends on the application conditions and the requirements of the customer. We recommend the igus® standard super aluminum guide troughs.

Glide bars

Glide bars made of igulen are optimally matched to the E-Chain® material and achieve the lowest values for friction, noise and wear. Glide bars must be used, if the fixed point is in the center of the travel. It means: Use half of the guide trough with glide bars and the other half of the guide trough without glide bars.

Delivery condition

The troughs are delivered in 2 meter sections. Special lengths up to 6 m are possible. The left and right side parts are installed on location with the appropriate distance - depending on the width of the E-Chain®. The necessary width is shown by the dimension BRI on the guide trough pages. The E-Chain® sides can be linked with the base through screwing, welding or a special igus® installation set. The fixation module for the igus® Super-Alu-Trough is a quick fix for mounting the stationary end of an E-Chain® with a KMA-mounting bracket. With this new module a fast and easy mounting onto the Super-Aluminum-Trough is possible without any drilling.

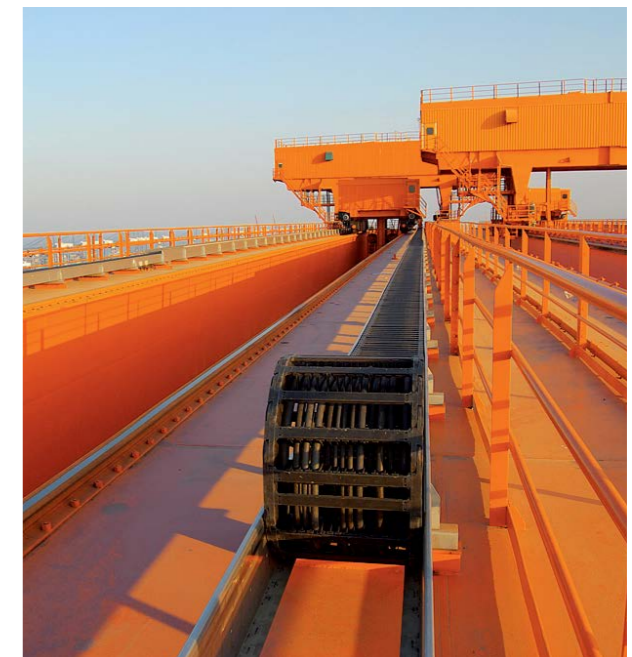

Trough without glide bars - E-Chain® glides on E-Chain®

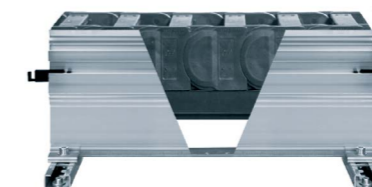

Trough with glide bars - E-Chain® glides on glide bars

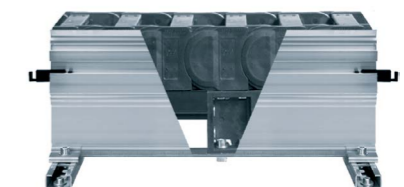

Center mounted: 1/2 Travel with glide bars - 1/2 Travel without glide bars

Triflex-R | 3D-E-Chain for robotics applications

2

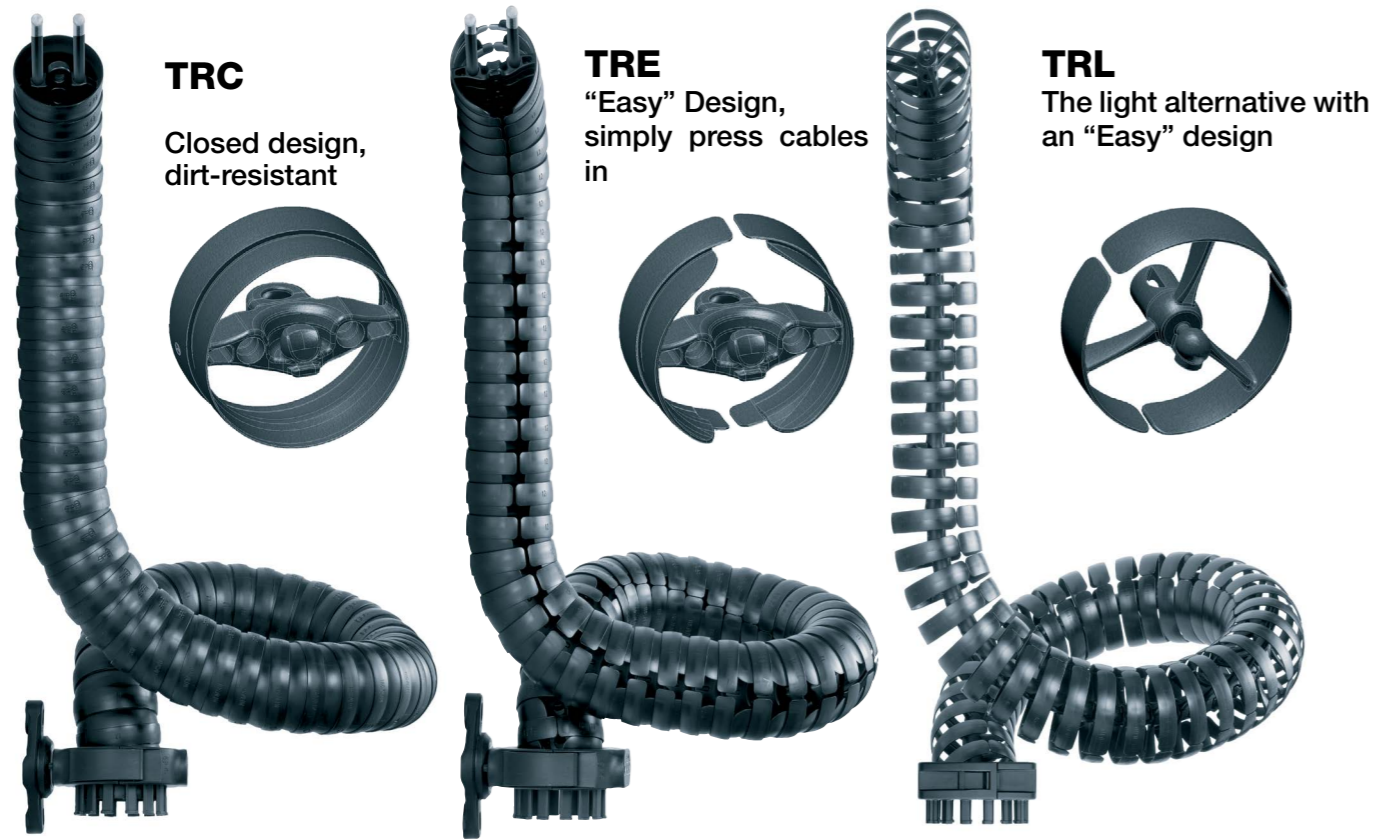

Series TRC - Dimensioning

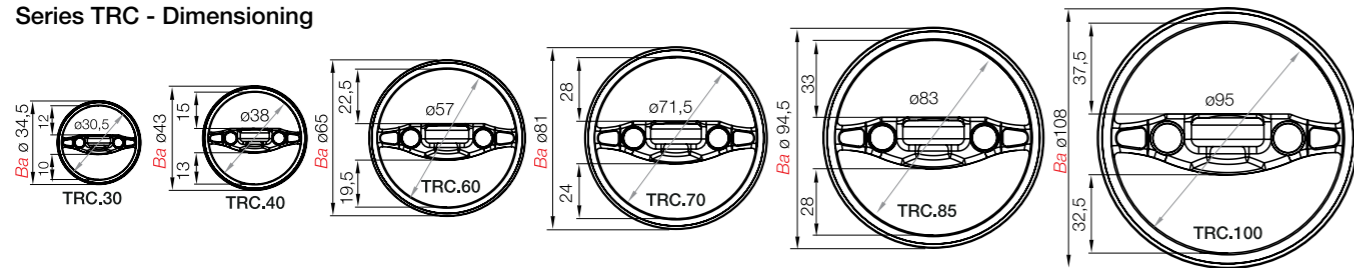

Series TRE - Dimensioning

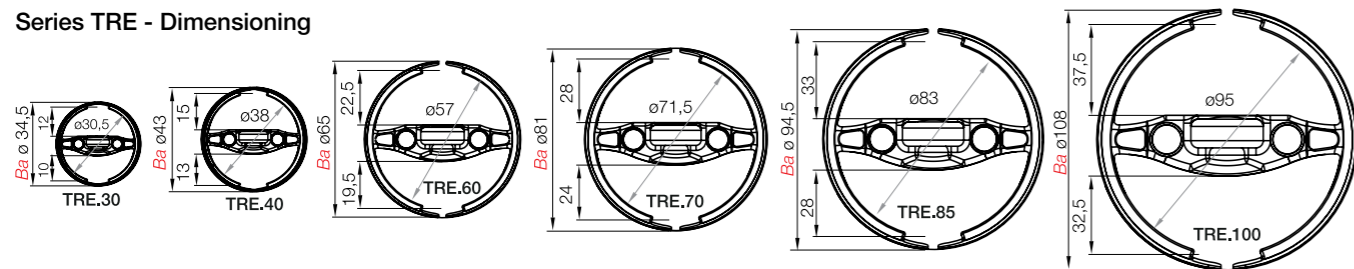

Series TRL - Dimensioning

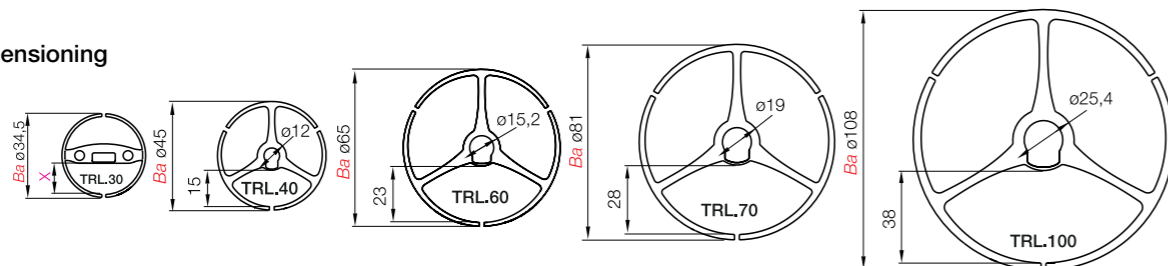

Triflex-R | TRC·TRE·TRL | Installation Dimensions

2

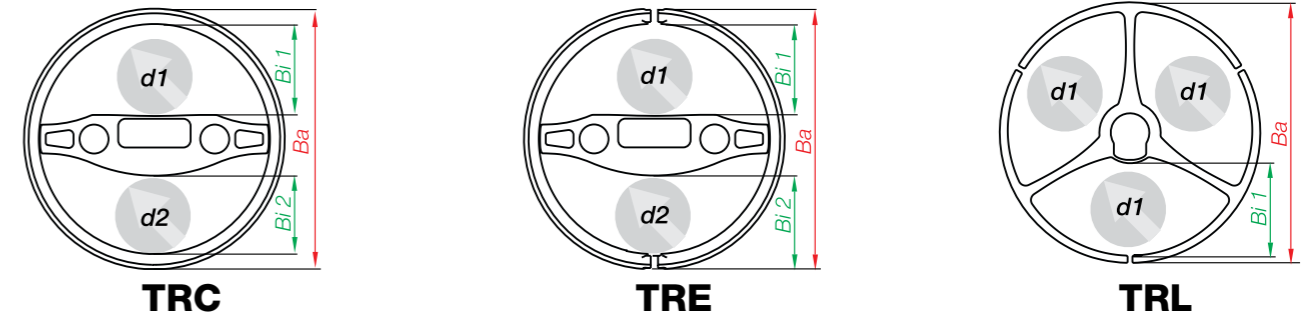

Part No.	Opening	principle	Inner height	Inner height	Outer width	Bending radii	max. ø cable	
			Bi 1 [mm]	Bi 2 [mm]			Ba [mm]	R [mm]
TRC.30. 050.0		closed design	12	10	34,5	050	10	8
TRC.40. 058.0		closed design	15	13	43	058	13	11
TRC.60. 087.0		closed design	22,5	19,5	65	087	20,5	17,5
TRC.70. 110.0		closed design	28	24	81	110	26	22
TRC.85. 135.0		closed design	33	28	94,5	135	31	26
TRC.100.145.0		closed design	37,5	32,5	108	145	35,5	30,5
TRE.30. 050.0		simply press cables in	12	10	34,5	050	10	8
TRE.40. 058.0		simply press cables in	15	13	43	058	13	11
TRE.60. 087.0		simply press cables in	22,5	19,5	65	087	20,5	17,5
TRE.70. 110.0		simply press cables in	28	24	81	110	26	22
TRE.85. 135.0		simply press cables in	33	28	94,5	135	31	26
TRE.100.145.0		simply press cables in	37,5	32,5	108	145	35,5	30,5
TRL.30. 050.0*		light - with "Easy" design	12	10	34,5	050	10	8
TRL.40. 058.0*		light - with "Easy" design	15	-	45	058	13	-
TRL.60. 087.0*		light - with "Easy" design	23	-	65	087	20,5	-
TRL.70. 110.0*		light - with "Easy" design	28	-	81	110	26	-
TRL.100.145.0*		light - with "Easy" design	38	-	108	145	35,5	-

*For quick and easy insertion / removal of cables using the Easy Chain® principle, we recommend a maximum cable diameter of 70% of the specified value.

Selecting the correct size Triflex-R

Filling and correct sizing - Clearance for cables and hoses is important when filling Triflex® R, in order to compensate for friction forces due to relative movement between E-Chain® and filling. The following serves as a rule of thumb: The total of all cable/ hose diameters must not exceed 60% of the available cross section. A clearance of min. 10% (min. 1mm) needs to be maintained towards the next cable and the Triflex® R. Please see the attached chart for available cross sections. Treotham will be glad to run such calculations for you.

For series TRC/TRE	Effective Areas (mm²)	For series TRL	Effective Areas (mm²)
TRC/TRE.30	313	TRL.30	313
TRC/TRE.40	508	TRL.40	670
TRC/TRE.60	1144	TRL.60	1242
TRC/TRE.70	1788	TRL.70	1499
TRC/TRE.85	2431	-	-
TRC/TRE.100	3176	TRL.100	4125
TRC/TRE.125	4584	-	-

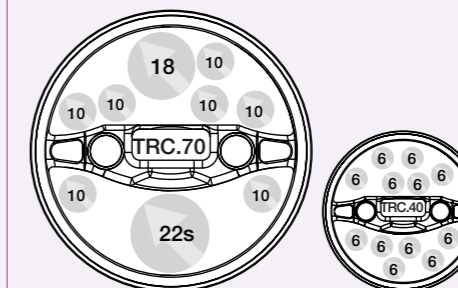

Examples of filling TRC.70 and TRC.40

Example of determining cable area

$$A_{\text{cable}} = d^2 \times \pi / 4$$

Examples

$$A_1 = (10\text{mm} \times 10\text{mm} \times \pi) / 4 = 78,5 \text{ mm}^2 \times 7 \text{ (number of cables)} = 549,50 \text{ mm}^2$$

$$A_2 = (18\text{mm} \times 18\text{mm} \times \pi) / 4 = 254,34 \text{ mm}^2$$

$$A_3 = (22\text{mm} \times 22\text{mm} \times \pi) / 4 = 379,94 \text{ mm}^2$$

$$\text{Total} = A_1 + A_2 + A_3 = 1183,7 \text{ mm}^2$$

Triflex-R | TRC·TRE·TRL | Mounting Brackets

2



Standard mounting brackets

- Quick and easy fixing
- Short downtimes when swapping a harnessed Triflex® R system
- Mounting bracket with strain relief available
- Mounting bracket also as intermediate link
- Bracket holes for common robot types

Part No. structure

TR.60. 01. M6

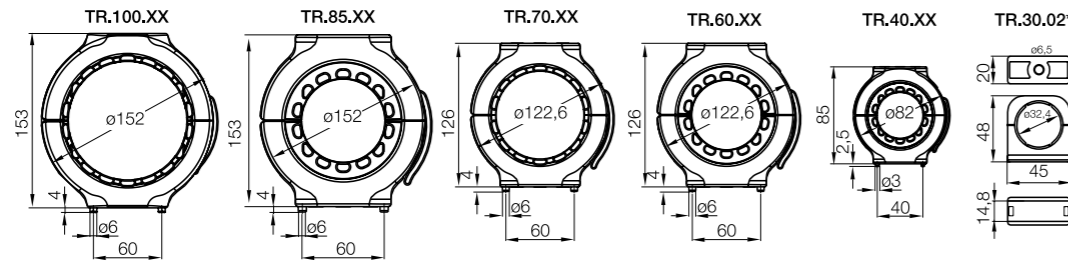
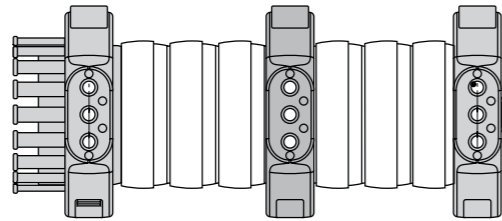
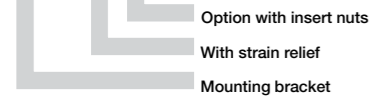

*For complete details of Mounting Brackets. Please contact your nearest Treotham Automation office.



Light mounting brackets

- Standard for TRL version, also compatible with all Triflex® R variants (TRC/TRE)
- Mounting bracket with strain relief available
- Mounting bracket also as intermediate link available
- Economical and light
- For simple 3D-movements and loads
- Comprising two halves - easy to assemble

Part No. structure

TL.40.01. Z2

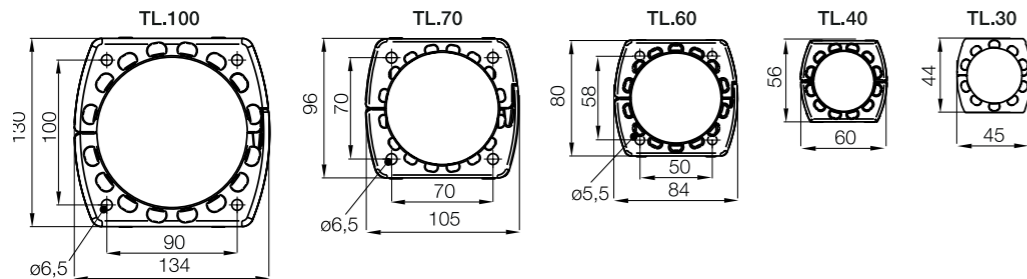
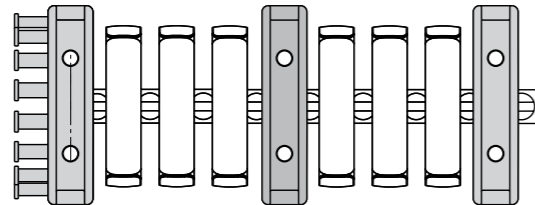
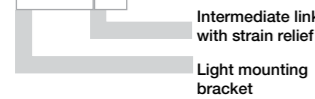

*For complete details of Mounting Brackets. Please contact your nearest Treotham Automation office.

Triflex-R | TRC·TRE·TRL | Additional Products



Swivel Bracket

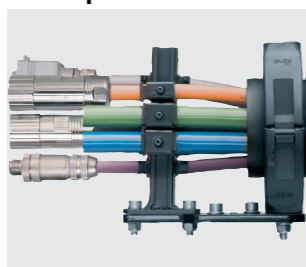

Strain Relief



Wear Protectors



Heat Shields

Triflex--R | TRC·TRE | Triflex-R-Set - universal module

2

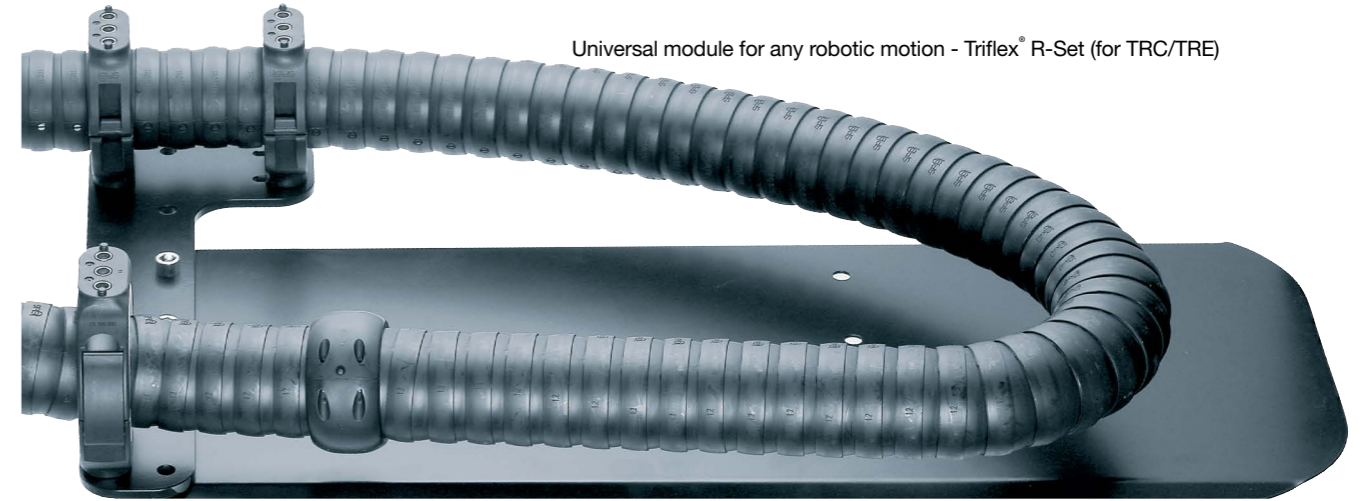

Universal module for any robotic motion - Triflex® R-Set (for TRC/TRE)

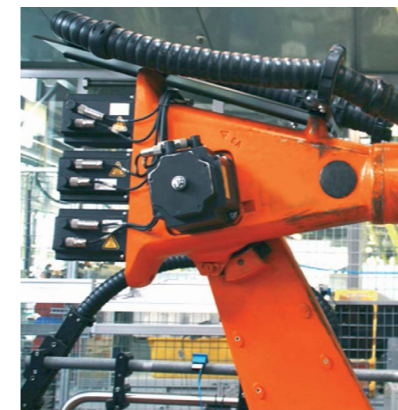

New universal module for any robotic motion

Triflex® RS is a very compact universal module that can be attached to the fastening points on the robot. Applications in very limited space can be realized, thanks to the small installation height and to the fact that Triflex® RS can be installed parallel to the robotic arm. Triflex® RS with integrated spring mechanism allows efficient energy supply to the robotic head, without stress on the cables. The new Triflex® R kit offers all advantages of proven Triflex® accessories, such as the FlexBar, universal assembly kit and fiber rod module in one system. All Triflex® R features are also included in the universal Triflex® RS module.

Standard-package for all applications for immediate installation

- Integrated spring mechanism
- The first choice for robotic applications with limited space
- Saves space - small installation height and closely routed on the robotic arm
- Outstanding service life
- Universal installation

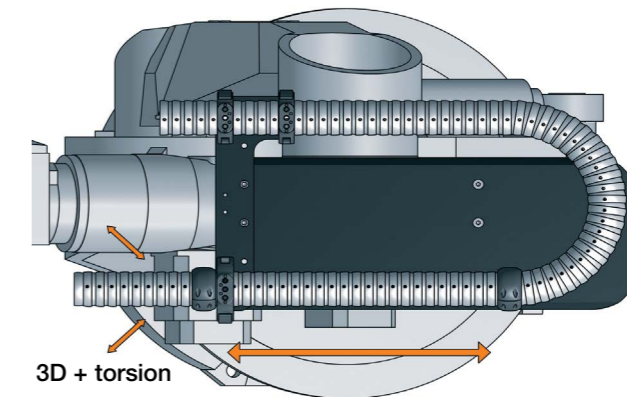

3D + torsion

Movement range
300 - 700 mm
(according to size)

Triflex® RS - many more features...



- TRS with cover**
- Creates additional building space
 - For upside down applications
 - For extreme movement

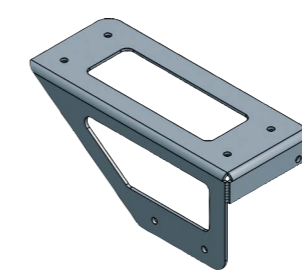

- TRS - adapter**
- Allows for Triflex® R Set fixation onto the robot
 - Available for all robot types
 - Standard module ex-stock



- TRS gliding duct**
- For smooth Triflex® R motion
 - Optimized geometry
 - Increases cycle life of your Triflex® R application

Rotary Motion RBR

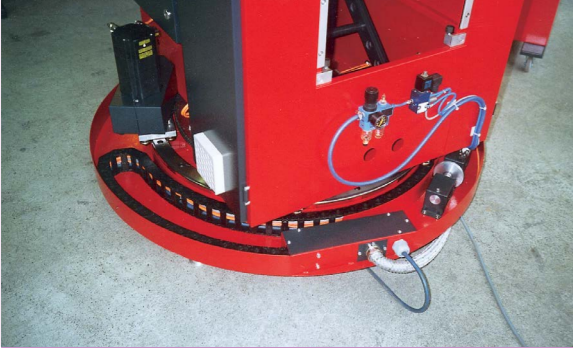

- RBR is "reverse bending radius" and means that the e-chain® can bend in two directions. Each igus® e-chain® can incorporate RBR designs, with the exception of several radii, for the e-tubes R117 to R9850 and for the Series 07, 09, 14, 15, and 17. The RBR does not necessarily need to be identical to the normal bending radius of an e-chain®.
- For example: Part No. 280.15.100/425.0, describes a Series 280 e-chain® with an inner width of 150 mm, standard bending radius of 100 mm and RBR of 425 mm. Most rotary motions can be achieved with the RBR option. Angles of rotation up to 540° have been realised.

E Spool

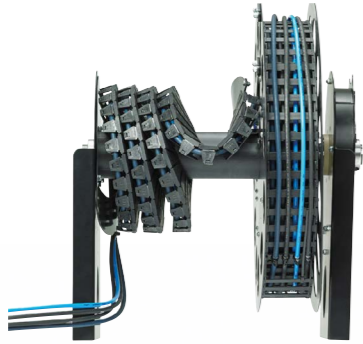

- Modular igus® e-spool from stock
- Various media and diameters possible in one drum Space-saving due to the energy chain being rolled up in the home position, keeping paths free of obstructions.
- Cable diameters up to 19 mm
- No strain on the cables
- Energy supply possible in all directions
- Cables can be retrospectively added or changed
- Various media can be guided in one system
- Alternative for Zig-Zag solutions
- Max. deployment and retract speed: 1 m/s

Twister Band



- Rotary movements up to 7000°
- (Installation position, vertical: up to 3.000°, horizontal: 7.000° and more possible)
- For smallest spaces
- Rotary speeds up to 360° are possible
- 4 sizes available
- Some parts available with interior separation
- Easy to fill with film-hinge or to be opened with "Easy"-principle
- Limited length adjustment possible

Roller e-chain®



- Rolling instead of gliding e-chains® are being used in ever longer travels. This has driven the development of the roller e-chain®. Additionally, movement speeds are increasing in combination with larger and larger fill weights (up to 50 kg/m).
- Major reduction in drive power to less than 25% for moving the e-chain®
- Travels up to 800 m possible
- Speeds up to 6 m/s possible
- Various roller types for optimum application adaptation. Can be used even in dirty environments. Available as ready-to-fit, made-to-specifications system. System guarantee for made-to-specifications systems

Basic Flizz

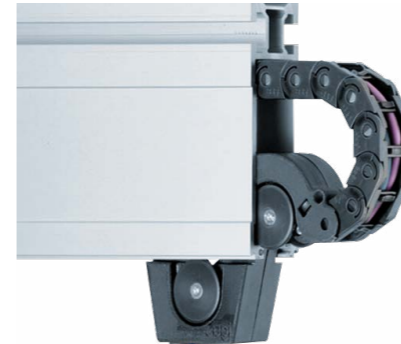

- Protection against weather and dirt exposure – Cost-effective and fully enclosed complete solution, e.g. waste water treatment plants
- Protection against weather and dirt exposure
- Cost-effective and fully enclosed complete solution e-chain®: for long travels up to 100 m
- Standardized and modular design
- Easy wall mounting or floor attachment
- Other sizes/versions available, up to 200 travel with E2 roller chains

Micro Flizz



- Smallest e-chain® without failures. One compact system for a secure guidance of power, data and air
- Maintenance-free alternative for busbar e-chain® is guided in special slot, no sliding against each other
- Control via stationary switch cabinet possible
- Accelerations up to 50 m/s² and speeds up to 6 m/s
- Fast assembly due to pre-configured, modular system
- Less space required
- Available also as pre-assembled
- Smooth running due to ball bearings in the guide carriages
- Also with EX tested e-chain® available (on request)
- Rail material: anodized aluminum

