



Solutions for multi-axis motion

e-spool®

The alternative to cable reeling drums - reduce cable wear and reliably guide different media together in one system



e-spool® advantages:

- Energy supply is possible in all directions (horizontal, vertical, diagonal)
- More versatile and flexible to use than cable reeling drums
- Different media (power, data and fluids) can be routed together in one system
- If travels must be kept free
- If the technical system is to be hidden behind false ceilings/floors



When to use another system:

- With very high loads that have to be guided vertically
 - ▶ zig-zag applications, page 127
- For high dynamics with lateral accelerations
 - ▶ guidelok slimline P, page 1152



The cable reel without a slip ring - igus® e-spool®

Routing many different cables in a small space: e-spool® uniquely combines two different energy supply systems. The one standard e-chain® is guided by a roller and always provides the correct length and tension of the energy supply system through an integrated retaining spring. In the starting position, the e-chain® is rolled up completely to save space. The twisterband connects the roller with the shaft end block, which serves as an interface to the supply side. With twisterband no slip ring is needed. This makes data transmission highly reliable, while enabling a high degree of flexibility at the same time. Different media and cable/hose diameters can be carried side by side in one drum (diameters up to 17mm)

- No tensile load on the cables
- Energy supply is possible in all directions (horizontal, vertical, diagonal)
- Space-saving when e-chain® is rolled into the home position, paths remain free
- Cables can be retrospectively added or changed
- Alternative to zig-zag solutions
- Maximum extension and retraction speed 1m/s
- Large standard product range and special projects available

Typical industries and applications

- Telescopic/retracting applications ● Theatre, stage technology ● Space-saving alternative to zig-zag solutions

 Available from stock. Ready to ship in 5 - 10 days*

*Average time before the ordered goods are dispatched.

e-spool® Variation	Part No. Series	Extension length ≤ [m]	Page
	e-spool® flex 2.0 continuous panel feed		
	SPF.250.08. <small>New*</small>	15	1132
	SPF.250.11. <small>New*</small>	10	1132
	SPF.250.15. <small>New*</small>	5	1132

e-spool® Variation	Part No. Series	Travel length ≤ [m]	Drum ø [mm]	Cable length [m]	Page
	e-spool® compact compact, space-saving				
	SP1.240.	2	240	4.0	1136
	SP1.400.	4	400	6.6	1136
	SPHD1.400. <small>New*</small>	4	400	6.6	1136

e-spool® for manual operation	Part No.	Travel length ≤ [m]	Drum ø [mm]	Cable length [m]	Page
for applications where only one cable or hose is pulled out manually					
	SPC1.300.	5	300	3.3 - 8.3	1138

e-spool® options	Part No. with 1 twisterband	Part No. with 2 twisterbands	Travel length ≤ [m]	Drum ø [mm]	Cable length [m]	Page
	e-spool® standard flexible use (Illustration shows e-spool® with 1 twisterband)					
	SP1.600.	SP2.600.	4	600	8.6	1141
	SP1.700.	SP2.700.	7	700	11.7	1141
	SP1.850.	SP2.850.	14	850	19.9	1141

e-spool® HD	Part No.	Travel length ≤ [m]	Drum ø [mm]	Cable length [m]	Page	
flexible use, with increased retraction force (Illustration shows e-spool® with 1 twisterband HD)						
	SPHD1.600.	SPHD2.600.	4	600	8.6	1142
	SPHD1.700.	SPHD2.700.	7	700	11.7	1142
	SPHD1.850.	SPHD2.850.	14	850	19.9	1142

e-spool® power	Part No.	Travel length ≤ [m]	Drum ø [mm]	Cable length [m]	Page
motor-driven, for long extension lengths					
	e-spool® power	25	upon request	upon request	1144
	Systems of this type should be designed in conjunction with our engineering team. Please contact us for the design of this plant ► www.igus.eu/contact				

*New in this catalogue

Technical data

 Max. speed	≤ 1m/s
Max. acceleration	≤ 1m/s ²
 Permitted temperature °C - e-spool® standard	0°C / +70°C
Permitted temperature °C - e-spool® HD	0°C / +80°C
Maximum fill weight, vertical	≤ 1kg/m



Guidelines for e-spool®

In view of the special mechanical stress inside an e-spool®, we recommend using igus® chainflex® cables. We also recommend that the following guidelines are observed:

1. Only put cables side by side in the linear chain - never stack them!
2. Where possible, chainflex® cables with a TPE outer jacket should be used for unshielded cables
3. Shielded cables should be chosen from the chainflex® CFROBOT range
4. The maximum bend radius of the twisterband must be accounted for
5. Where possible, use separators to protect cables against cross-over and abrasion against each other. To make the best possible use of the interior space, install the separator in alternate links
6. Insert cables sorted by diameter and/or bend radius - insert small ones in the centre then increasingly larger ones towards the outside
7. Apply strain relief to both ends of the cable - when using a cable tie for strain relief, please ensure the head of the cable tie is underneath to avoid cable damage
8. The cables should be installed in the twisterband with clearance space both outwards and inwards from the rotary axis

Installation instructions

For applications that move horizontally, a smooth surface is required for the e-chain® to travel over.



e-spool® - the solution for stage and theatre technology. Supplying energy, data and fluids without interruption. As shown here, at the Cultural and Congress Centre in Toruń (Poland). A total of ten igus® HD e-spool® systems have been installed

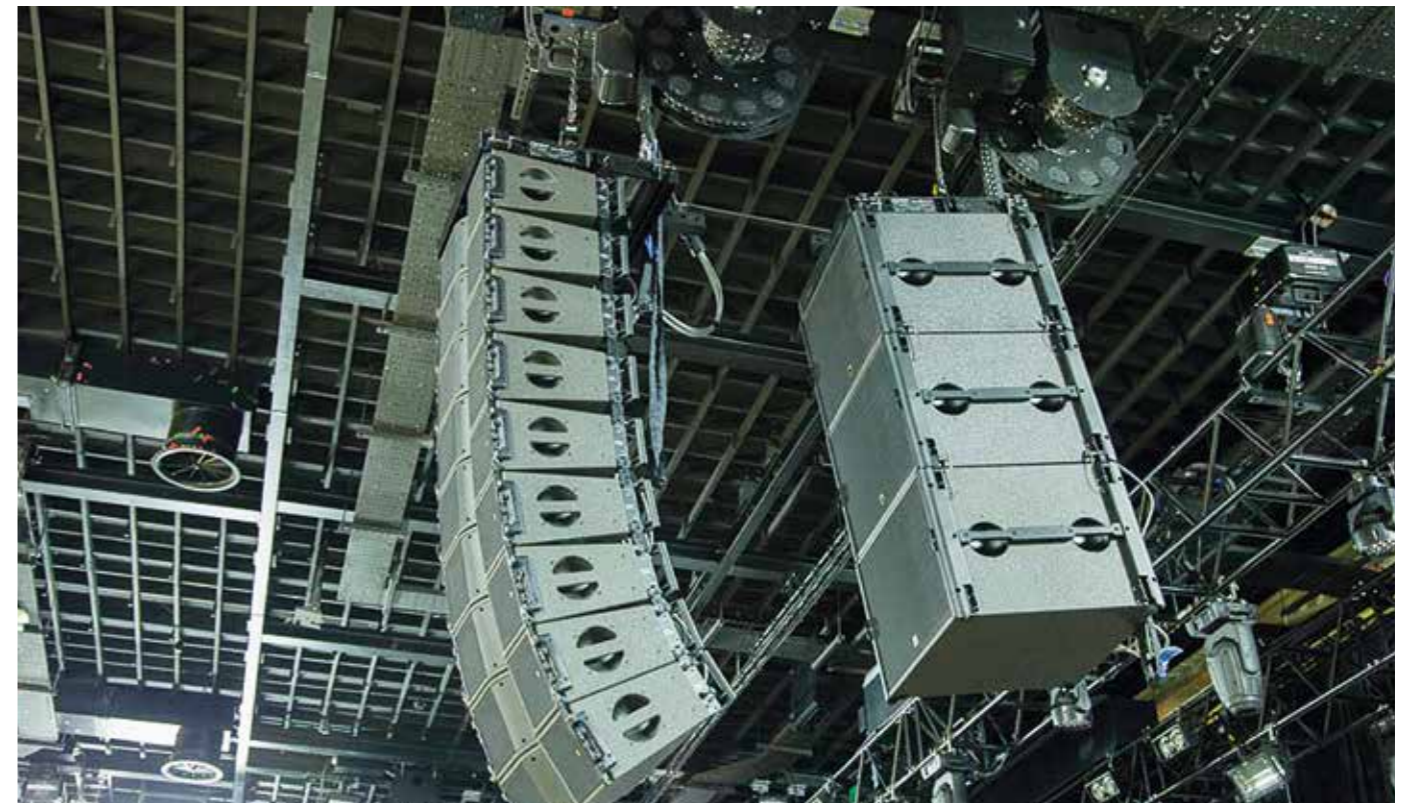

At Liverpool University (in the UK), e-spools® supply power and data to arrays of height-adjustable speakers. End to end cables ensure the best possible transmission reliability and sound quality



Easy handling: pull-out force is almost constant and secure locking

Without interruption: for energy, data, fluids and air

Assembly-friendly: easy replacement of the cable, even with connectors fitted

Space-saving: cable retracts into a compact unit

Continuous panel feed - e-spool® flex 2.0

The e-spool® flex 2.0 is the igus® cable drum without a slip ring. Cables diameters from 5mm to 15mm can be used. The cable is always safely routed through a feed-through to ensure that it is properly wound at all times.

- Without interruption (no slip ring), for energy, data, fluids and air
- Space-saving
- Universal use
- Constant tensile force on the cable
- Locking mechanism for the cable
- Cost-effective
- Easy in case of repair
- Simple replacement of the fitted cable, therefore adaptable
- Four configurations, adaptable to the respective applications

Typical industries and applications

- Wherever a cable needs to move freely in use and be stowed away safely after use
- Panel pull-out on robots
- Cable retraction system for workshop, measuring and production areas
- In medical technology
- Machine tools
- Indoor cranes, etc.

For cable diameters from 5 to 15mm

e-spool® flex 2.0

Part No..	Cable diameter from - to ≤ [mm]	Extension length ≤ [m]	Required cable length inside the chain [m]	Weight [kg]
e-spool® flex 2.0				
SPF.250.08.01.*	5 - 8	15	4.5	≈ 8.0
SPF.250.11.01.*	8 - 11	10	3.3	≈ 8.0
SPF.250.15.01.*	11 - 15	5	2.4	≈ 8.0

*Note: *Part can be combined with four different drives (H/T/SP/SB)

Complete Part No. with index of required drive (H/T/SP/SB). Example: **SPF.250.11.01.H**

4 models with the corresponding order index | Overview

Drive options	Index	Meaning
A hand crank	H	H and
For cordless screwdriver*	T	T ool
With retaining spring and locking mechanism	SP	S pring with P osition Hold
With retaining spring, locking mechanism and retraction brake	SB	S pring with Position Hold and B reak

*Available upon request. Please consult igus® for delivery time.

Order key and calculation example | e-spool® flex 2.0

<p> Order key SPF.250.11.01.H</p> <p>Series / Type</p> <p>Drum diameter: 250mm</p> <p>For cable diameters from 8mm to 11mm</p> <p>Standard colour black</p> <p>A hand crank</p>	<p> Order key SPF.250.11.01.T</p> <p>Series / Type</p> <p>Drum diameter: 250mm</p> <p>For cable diameters from 8mm to 11mm</p> <p>Standard colour black</p> <p>Reeling possible by means of a battery-powered screwdriver</p>
<p> Order key SPF.250.11.01.SP</p> <p>Series / Type</p> <p>Drum diameter: 250mm</p> <p>For cable diameters from 8mm to 11mm</p> <p>Standard colour black</p> <p>With retaining spring and locking mechanism</p>	<p> Order key SPF.250.11.01.SB</p> <p>Series / Type</p> <p>Drum diameter: 250mm</p> <p>For cable diameters from 8mm to 11mm</p> <p>Standard colour black</p> <p>Retaining spring locking mechanism and retraction brake</p>

Calculation: total cable length = extension length + cable length e-spool® flex + protrusion FP (connection source)
Example SPF.250.11.01.H: total cable length = 10m + 3.3m + 5m (protrusion FP) = 18.3 metres



Cables or hoses are inserted into the e-spool® in a spiral pattern



The e-spool® flex in detail from the inside (from left): housing, spiral guide, cables/hoses, winding housing

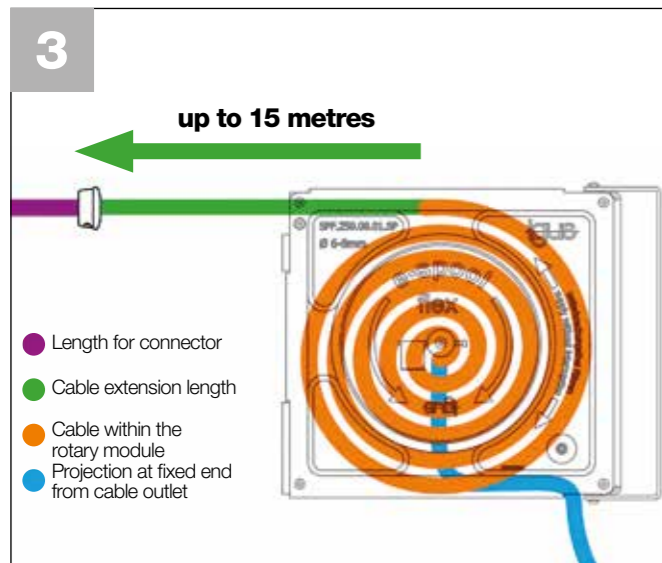

Cable/hoses inserted in the spiral guide - extension length up to 15m possible

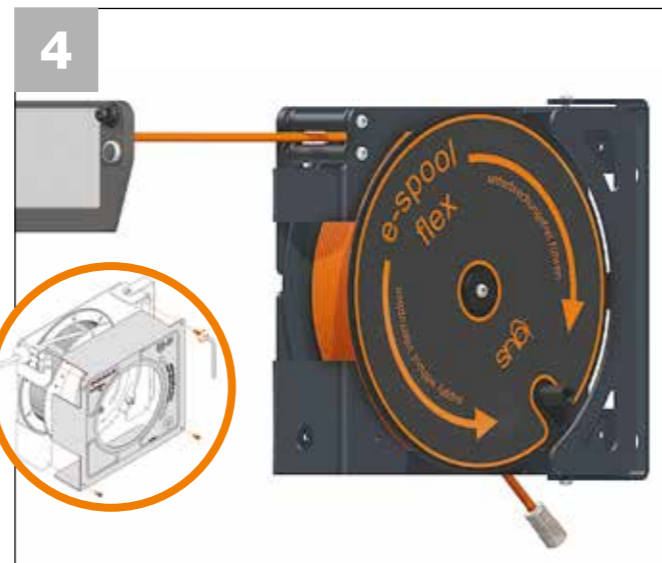

The e-spool® flex 2.0 system is simple to set up, making it easy and quick to replace the cable if necessary

i Please consider VDE 0298 part 5 (current carrying capacity and conversion factors for wound cables) when selecting your cables and using e-spool® flex

w Assembly instructions - the illustrated assembly aid enables you to assemble the e-spool® flex 2.0 quickly and professionally ► www.igus.eu/e-spool-flex



Pull-out forces e-spool® flex vs. Competitive product

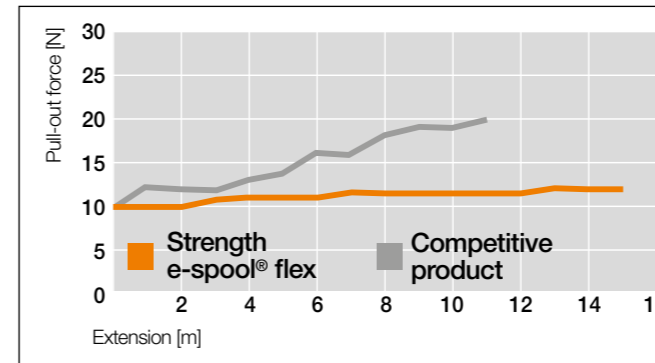

Tested for e-spool® flex pull-out forces

In its test laboratory, the largest in the industry, igus® compared the e-spool® flex with a competing product. The test evaluated the two products' pull-out forces.

The results showed that the e-spool® pull-out forces were about 10 newtons, while those of the competing product were almost twice that.

Cable drum without slip ring - advantages of the interruption-free panel feed e-spool® flex 2.0

Newly developed cable drum for control panels. Since the new solution does not use slip rings, media, data and the power and signal supply of the emergency stop button can also be integrated into the system.

Download the white paper ► www.igus.eu/e-spool-flex



e-spool® flex 2.0 - suitable for many industries and applications. Here on a pendant for robots

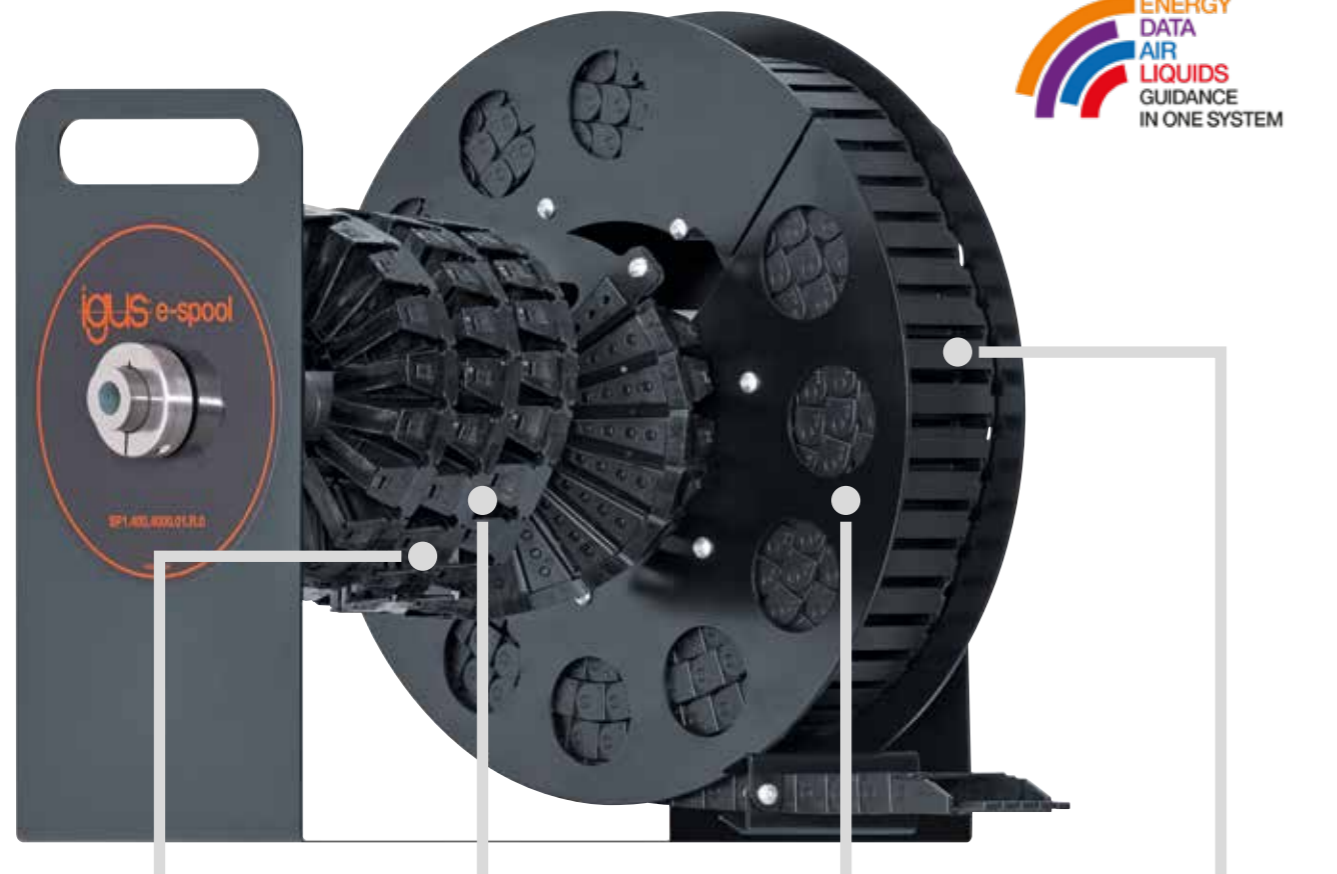

Flexible use:
energy supply in any
direction is possible

Cost-effective:
twisterband enables
rotary movement

Flexible energy supply:
guidance of different
media in one system

Space-saving:
e-chain® retracts into
a compact unit

Compact, space-saving cable reel without slip ring - e-spool® compact

The compact e-spools® for 2m and 4m extension are optimised for small installation spaces with smaller linear chains and twisterbands for a wide range of applications. As with the larger standard and HD systems, the compact e-spool® systems enable trouble-free guidance and flexible filling.

- Compact, space-saving cable reel without slip ring
- Different media (power, air data and fluids) can be routed together in one system
- Energy supply in all directions
- Space-saving and virtually "invisible"
- Very lightweight design (SP1.240 series made from aluminium)
- Extension lengths up to 2 and 4m
- Cables can be retrospectively added or changed

Typical industries and applications

- Manual workplaces ● Workstations ● Assembly lines ● Small telescopic applications

Route various media in a space-saving and flexible way

e-spool® compact | With e-chain® and 1 twisterband

Part No. e-spool® with 1 twisterband, extension right	Bi [mm]	hi [mm]	Travel length ≤ [m]	Weight [kg]
SP1.240.2000.01.R.0 ¹⁾	23	9	2	≈ 3.30
SP1.400.4000.01.R.0 ²⁾	44	15	4	≈ 13.5
SPHD1.400.4000.01.R.0 ²⁾	44	15	4	≈ 17.2

Maximum cable and hose diameters: for SP1.240 = 7mm and for SP1.400 = 12mm

1) The max. bend radii of 24mm in the inner radius and 35mm in the outer radius should be observed

2) The max. bend radii of 34mm in the inner radius and 57mm in the outer radius should be observed

i Note: The compact e-spools® for 2m and 4m extension are optimised for small installation spaces with smaller linear chains and twisterbands for a wide range of applications. As with the larger standard and HD systems, the compact e-spool® systems enable trouble-free guidance and flexible filling.

SP1.240.2000.01.R.0

- 1 twisterband
- Drum diameter ø
- Max. extension length
- Version number
- Extension R / L
- Standard colour black

Order key - e-spool® compact

Compact system with a single twisterband with 240mm drum diameter, and 2,000mm maximum extension length, extension right

e-spool® compact | Interior separation

twisterband interior separation - separators are delivered unassembled. Simply pushed onto the openable crossbar. Separators are assembled every 4th e-chain® link.

Separator, for TB20.44.18 unassembled TB20.18.2

Interior separation for twisterband

Separators - for installation simply open the e-chain®, insert a cable and press the separator onto the crossbar.



- Flexible use: energy supply in any direction is possible
- Locking: inertia locking function
- Flexible energy supply: for routing of a single cable or hose
- Space-saving: cable retracts neatly when not in use, paths remain free

For applications where only one cable or hose is pulled out manually - e-spool® for manual operation

The manually operated e-spool® is designed for applications where only one cable or hose is pulled out by hand. The operator pulls out the cable to the required length for a control pendant or tool and can be retracted again after use. To prevent the cable from being under tension all the time, an inertia reel is fitted. In this way, the extension length can be locked. An extension length of up to 5m can be insert achieved.

- For applications where one cable or hose is pulled out manually
- Compact, space-saving cable reel without slip ring
- Integrated ratchet to lock/release the retraction (very similar to a vacuum cleaner cable)
- Also suitable for media or air hoses
- Handle with mounting option and strain relief

Typical industries and applications

- Robot teach pendants ● Workstations ● Assembly lines

Retract a single cable or hose compactly

e-spool® with manual operation | With 1 twisterband

Part No. e-spool® with	hi	Travel length	Weight
1 twisterband, extension right	[mm]	≤ [m]	[kg]
SPC1.300.5000.01.R.0	18	5	≈ 12.5

Maximum cable or hose diameters: 12mm

The max. bend radii of 57mm should be observed.

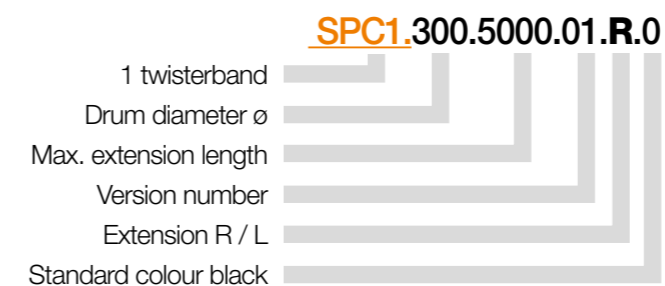

Order key - e-spool® for manual operation

System for manual operation with a single twisterband with 300mm drum diameter and 5,000mm maximum extension length, extension right

e-spool® for manual operation | Interior separation

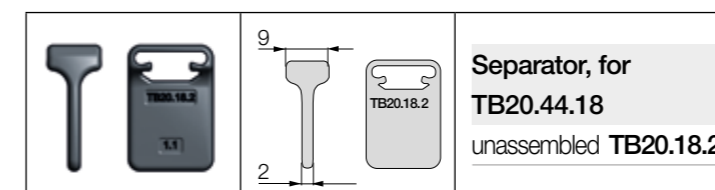
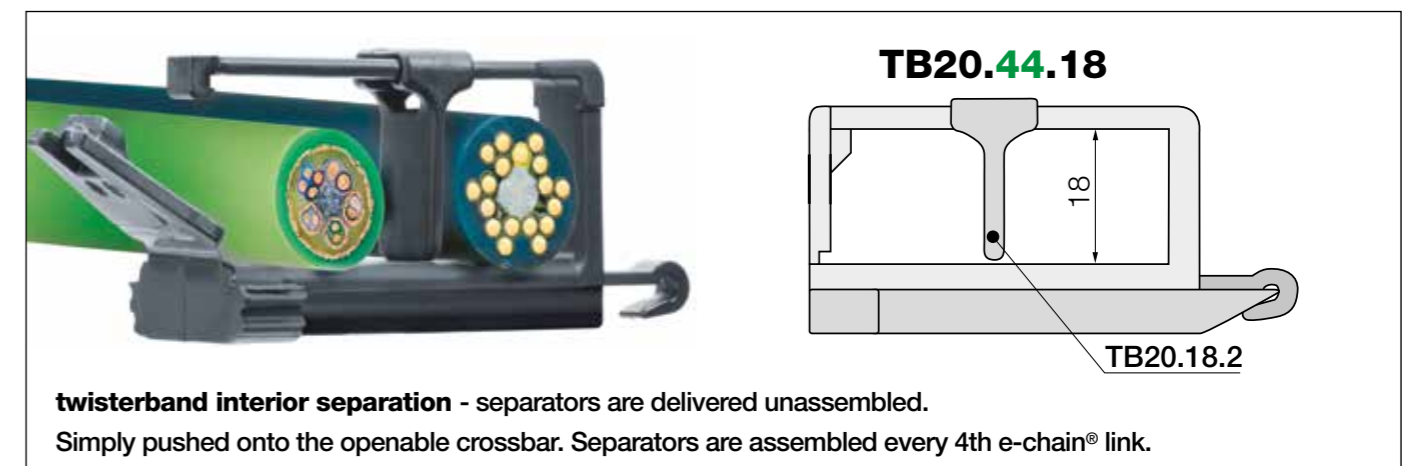

Separator, for TB20.44.18 unassembled TB20.18.2

Interior separation for twisterband

Separators - for installation simply open the e-chain®, insert a cable and press the separator onto the crossbar.



Flexible use:
energy supply in any
direction is possible

Cost-effective:
HD twisterband enables
rotary movement

Flexible energy supply:
guidance of different
media in one system

Space-saving:
e-chain® retracts into
a compact unit

Flexible use - igus® e-spool® standard and HD

With igus® e-spools®, cables are wound up in an e-chain® to save space. Various media can be supplied without interruption by the use of the twisterband. Adjustments and extensions of the filling are also possible at any time afterwards.

- Flexible energy supply - guidance of different media in one system
- Flexible use - energy supply in any direction is possible
- Cost-effective - twisterband enables rotary movement
- Space-saving - e-chain® retracts into a compact unit
- No tensile load on the cables
- Cables can be retrospectively added or changed

Typical industries and applications

- Telescopic/retracting applications
- Theatre, stage technology*
- Space-saving alternative to zig-zag solutions

*The standard and HD e-spool® series are not in accordance with the stage technology guidelines DIN EN 17206.



2013

Reduce cable wear and reliably guide different media together in one system

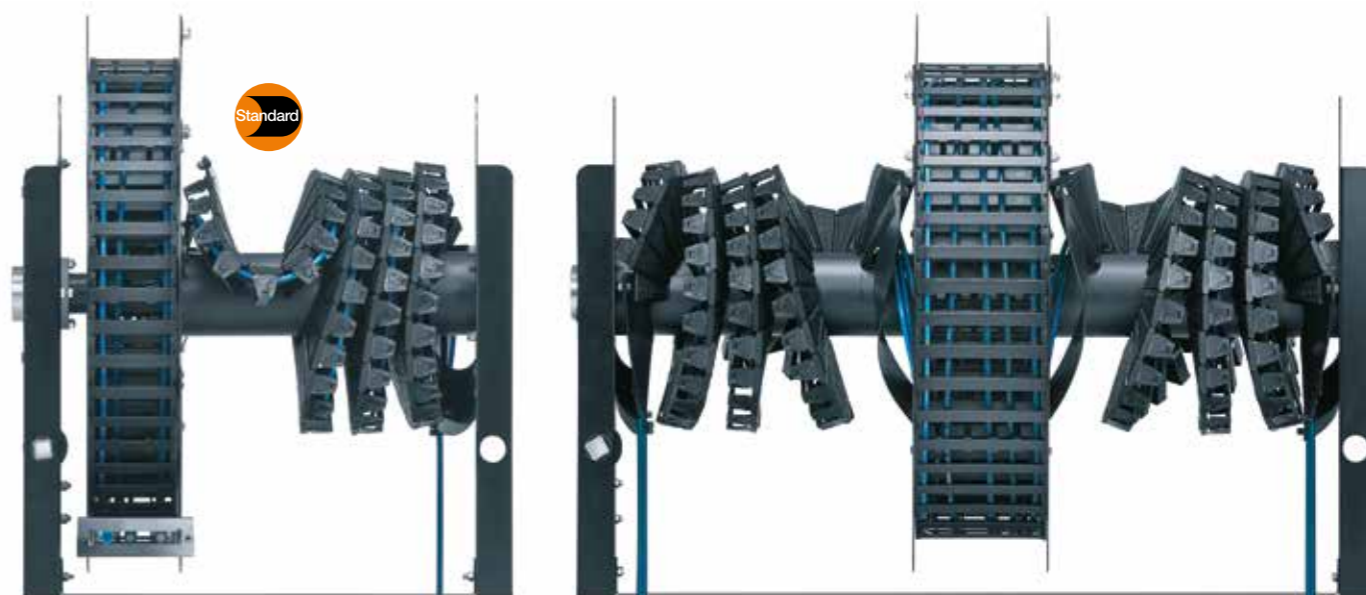

Illustration shows e-spool® standard with 1 and 2 twisterbands

e-spool® standard | With e-chain® and 1 or 2 twisterbands

Part No. e-spool® with 1 twisterband, extension right	Part No. e-spool® with 1 twisterband, extension left	<i>Bi</i> [mm]	<i>hi</i> [mm]	Travel length ≤ [m]	SP1 [kg]
SP1.600.4000.03.R.0	SP1.600.4000.03.L.0	75	21	4	≈ 33.0
SP1.700.7000.03.R.0	SP1.700.7000.03.L.0	75	21	7	≈ 38.0
SP1.850.14000.03.R.0	SP1.850.14000.03.L.0	75	21	14	≈ 48.0

Maximum cable or hose diameters: 17mm

The max. bend radii of 44mm in the inner radius and 77mm in the outer radius should be observed.

Part No. e-spool® with 2 twisterbands, extension right	Part No. e-spool® with 2 twisterbands, extension left	<i>Bi</i> [mm]	<i>hi</i> [mm]	Travel length ≤ [m]	SP2 [kg]
SP2.600.4000.03.R.0	SP2.600.4000.03.L.0	125	21	4	≈ 40.0
SP2.700.7000.03.R.0	SP2.700.7000.03.L.0	125	21	7	≈ 45.0
SP2.850.14000.03.R.0	SP2.850.14000.03.L.0	125	21	14	≈ 55.0

Maximum cable or hose diameters: 17mm

The max. bend radii of 44mm in the inner radius and 77mm in the outer radius should be observed.

i Note: If the e-chain® extension is vertically upwards, igus® recommends the standard e-spool®. For vertical downwards, please use the HD version. For horizontal pull-out direction, the choice of system depends on the application. To select the right system, please get in touch with igus®.

	SP1.600.4000.03.R.0
1 twisterband	
Drum diameter ø	
Max. extension length	
Version number	
Extension R / L	
Standard colour black	

i Order key - e-spool® standard

Standard system with a single twisterband with 600mm drum diameter, and 4,000mm maximum extension length, extension right

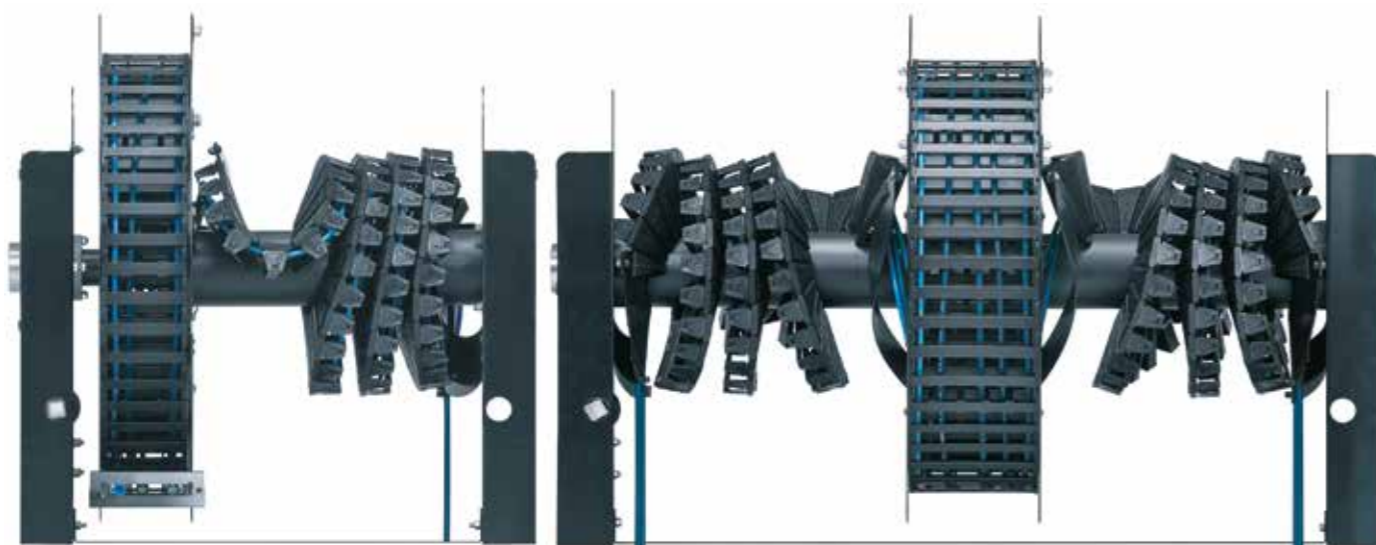

Illustration shows e-spool® HD with 1 and 2 twisterbands

e-spool® HD | With e-chain® and 1 or 2 twisterbands

Part No. e-spool® HD with 1 twisterband, extension right	Part No. e-spool® HD with 1 twisterband, extension left	<i>Bi</i> [mm]	<i>hi</i> [mm]	Travel length ≤ [m]	SP1 [kg]
SPHD1.600.4000.03.R.0	SPHD1.600.4000.03.L.0	75	21	4	≈ 52.0
SPHD1.700.7000.03.R.0	SPHD1.700.7000.03.L.0	75	21	7	≈ 56.5
SPHD1.850.14000.03.R.0	SPHD1.850.14000.03.L.0	75	21	14	≈ 67.0

Maximum cable or hose diameters: 17mm

The max. bend radii of 44mm in the inner radius and 77mm in the outer radius should be observed.

Part No. e-spool® HD with 2 twisterbands, extension right	Part No. e-spool® HD with 2 twisterbands, extension left	<i>Bi</i> [mm]	<i>hi</i> [mm]	Travel length ≤ [m]	SP2 [kg]
SPHD2.600.4000.03.R.0	SPHD2.600.4000.03.L.0	125	21	4	≈ 59.0
SPHD2.700.7000.03.R.0	SPHD2.700.7000.03.L.0	125	21	7	≈ 64.0
SPHD2.850.14000.03.R.0	SPHD2.850.14000.03.L.0	125	21	14	≈ 74.0

Maximum cable or hose diameters: 17mm

The max. bend radii of 44mm in the inner radius and 77mm in the outer radius should be observed.

i Note: If the e-chain® extension is vertically upwards, igus® recommends the standard e-spool®. For vertical downwards, please use the HD version. For horizontal pull-out direction, the choice of system depends on the application. To select the right system, please get in touch with igus®.

SPHD2.850.14000.03.R.0

- 2 HD twisterbands
- Drum diameter ø
- Max. extension length
- Version number
- Extension R / L
- Standard colour black

Order key - e-spool® HD

HD system with two twisterbands with 850mm drum diameter, and 14,000mm maximum extension length, extension right

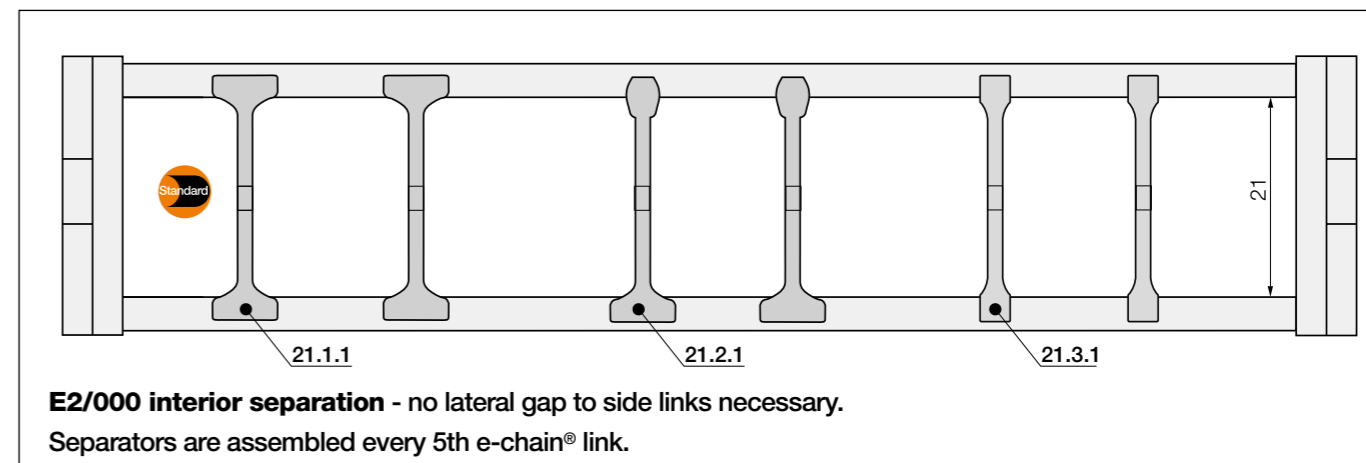

Standard separator, wide base	unassembled	21.1
	assembled	21.1.1

Interior separation for E2/000 e-chains® Standard - for any application

Separator with a wide base for maximum holding force in the e-chain®.

Separator, narrow top	unassembled	21.2
	assembled	21.2.1

For even faster installation

Wide on one side for high holding force, narrow on opposite side for easy cable fitting.

Separator, narrow	unassembled	21.3
	assembled	21.3.1

For small cables

Separator with a narrow base for a large number of small cables side by side. Saves space in the e-chain®.

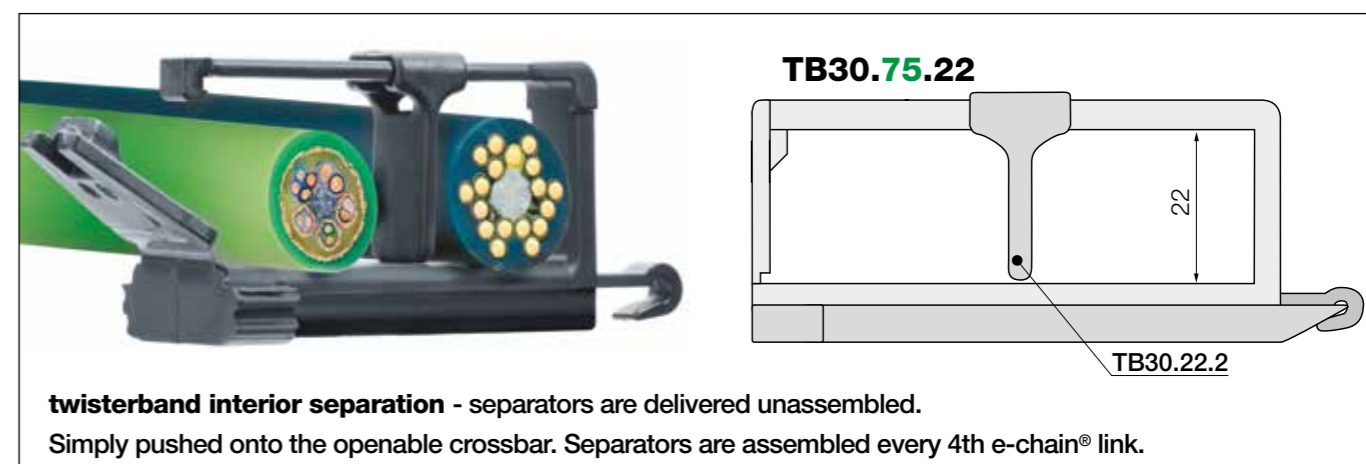

Separator, for TB30.75.22	unassembled	TB30.22.2
---------------------------	-------------	-----------

Interior separation for twisterband

Separators - for installation simply open the e-chain®, insert a cable and press the separator onto the crossbar. Then add more cables. The separators provide a clear, cable-friendly interior separation.

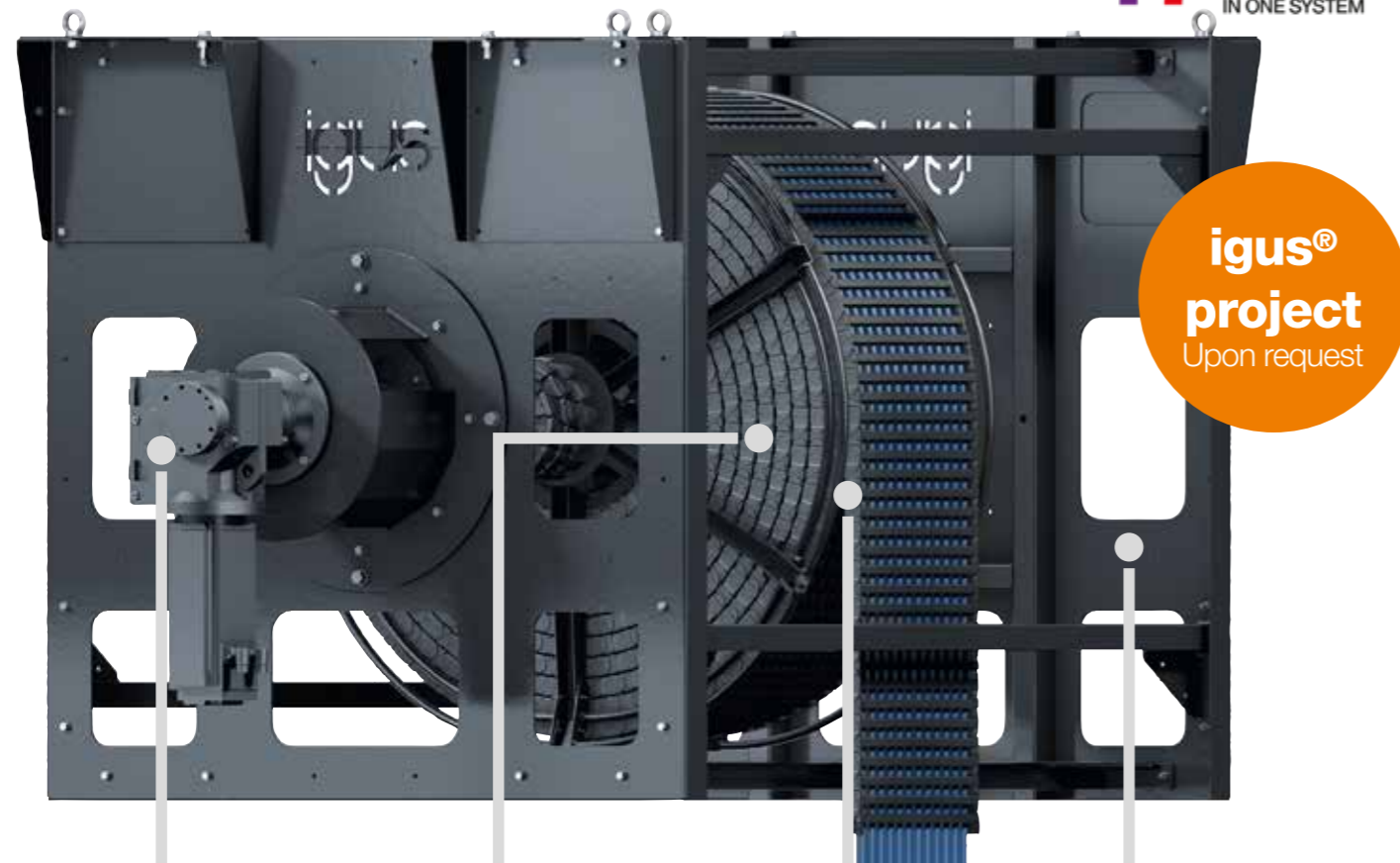

- Motor-driven: for extension lengths up to 25m
- Flexible energy supply: guidance of different media in one system
- Space-saving: e-chain® retracts into a compact unit
- Optional control system: plug & play controller, developed by igus®

Motor-driven for long extension lengths - e-spool® power

The e-spool® power is a motor-driven e-spool® for travels up to 25m. Like all e-spool® systems, it can be filled with various cables and hoses and ensures reliable transmission with no breaks or slip rings. An igus® controller, which adapts dynamically to the travel speed, was specially developed for vertically hanging applications in theatres and opera houses and can be ordered as an option.

- Travel distances up to 25m (longer distances upon request)
- Solid tubular steel construction
- Flexible filling with electrical and fibre optic cables, and pneumatic hoses
- Future-proof, additions and upgrades possible
- No tensile load on the cables

Typical industries and applications

- Theatre, stage and lighting technology
- Indoor and outdoor cranes

Systems of this type should be designed in conjunction with our engineering team.
Please contact us for the design of this plant ► www.igus.eu/contact

