

zipper

Zip fastening e-chains® and e-tubes



Advantages of the zipper series:

- zipper-like design for quick opening and closing of lids
- zipper e-chains® can be lengthened and shortened at any point
- Small pitch for low noise, smooth running
- Interior separation possible



When to use another e-chain® series:

- When an easy filling without opening and closing of the chain is required
 - ▶ easy chain®, page 212
- If an easy-to-open and cost-effective e-chain® is required
 - ▶ E2.1 micro, page 334
- If openable crossbars are not necessary
 - ▶ E2 micro, page 274



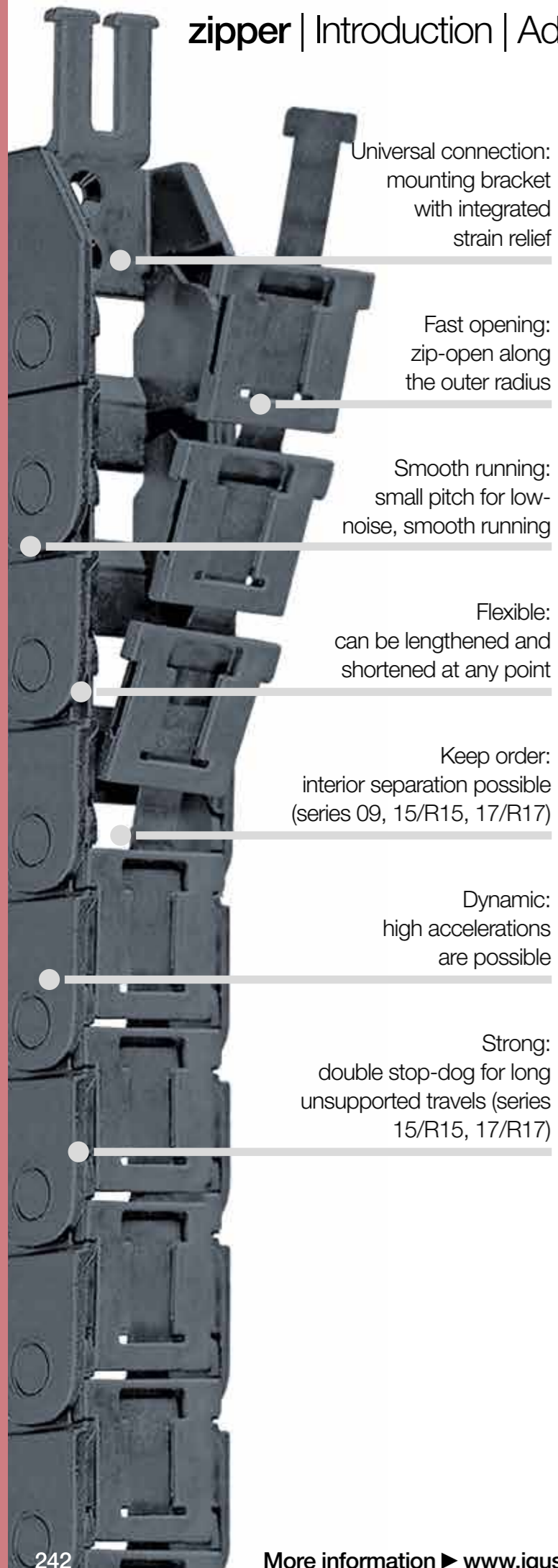

Universal connection:
mounting bracket
with integrated
strain relief

Fast opening:
zip-open along
the outer radius

Smooth running:
small pitch for low-
noise, smooth running

Flexible:
can be lengthened and
shortened at any point

Keep order:
interior separation possible
(series 09, 15/R15, 17/R17)

Dynamic:
high accelerations
are possible

Strong:
double stop-dog for long
unsupported travels (series
15/R15, 17/R17)

Zip fastening e-chains® and e-tubes - zipper

igus® "zipper" e-chains® and e-tubes deliver in terms of practicality and performance. The "zipper" function makes them a very useful product to reduce assembly time. The small pitch, the tough-elastic zipper-band, and the sturdy link work well in high acceleration applications. The "zipper" series is one of the most popular igus® e-chain® series for demanding applications.

- zipper-like design for quick opening and closing of lids
- zipper e-chains® can be lengthened and shortened at any point
- Small pitch for low noise, smooth running
- High accelerations: 100m/s² and more

Typical industries and applications

- Pick & place robots
- Semi-conductor machines
- Linear motors, actuators
- Measuring equipment
- Machine tools (zipper e-tube)
- General machinery, etc.

58 dB(A) - value determined at the igus® test-lab, v = 1.0m/s unsupported, series 09.50.028.0

UL94-V0 classification upon request

Electrically conductive ESD e-chains® - several series available from stock

iF product design award
2002 igus® Series R09
1989 igus® Series 15

Series	Inner height <i>hi</i> [mm]	Inner width <i>Bi</i> [mm]	Outer width <i>Ba</i> [mm]	Outer height <i>ha</i> [mm]	Bend radius <i>R</i> [mm]	Unsupported length ≤ [m]	Page
--------	--------------------------------	-------------------------------	-------------------------------	--------------------------------	------------------------------	--------------------------	------



zipper - e-chains®
crossbars on a strip - zip-open along the outer radius

047	9	10 - 16	16 - 22	12.5	018 - 038	0.40	246
07	10.3	06 - 64	12.5 - 71	15	018 - 048	0.55	248
09	15	10 - 64	18.2 - 72.2	19.3	028 - 048	1.00	252
15	17	15 - 100	26 - 113	24	038 - 180	1.20	258
17	32	15 - 100	25.5 - 113	39	063 - 125	1.00	266



zipper - e-tubes - protection against dirt and swarf
lids on a strip - zip-open along the outer radius

R07	10.3	10 - 50	16.5 - 57	15	038 - 048	0.55	250
R09	15	10 - 50	18.2 - 58.2	19.3	048 - 100	1.00	256
R15	17	25 - 80	36 - 94	24	063 - 180	1.20	262
R17	32	15 - 63	26 - 74	39	063 - 125	1.20	270

Available from stock. Ready to ship in 24 - 48hrs.*
*Average time before the ordered goods are dispatched.

Technical data

	Speed gliding / acceleration gliding	≤ 10 [m/s] / ≤ 50 [m/s ²]
	Speed FL_G / acceleration FL_G	≤ 20 [m/s] / ≤ 200 [m/s ²]
	Speed FL_B / acceleration FL_B	≤ 3 [m/s] / ≤ 6 [m/s ²]
	Material lower part - permitted temperature °C, igumid G	-40°C / +120°C
	Material lid - permitted temperature °C, igumid TE	-40°C / +70°C
	Flammability class, igumid G	VDE 0304 IIC UL94-HB

■ **FL_G** = unsupported with straight upper run ■ **FL_B** = unsupported with permitted sag

Installation types, maximum travels

Series	Unsupported	Vertical hanging	Vertical standing	Side mounted unsupported
047	≤ 0.80m	upon request	upon request	upon request
07 / R07	≤ 1.10m	upon request	upon request	upon request
09 / R09	≤ 2.00m	upon request	upon request	upon request
15 / R15	≤ 2.40m	upon request	upon request	upon request
17 / R17	≤ 2.00m	upon request	upon request	upon request

Options with order keys | Examples based on series 15

	Standard	NC version - (No Camber) without pretension	ESD - electrically conductive material
	Part No. Standard	Part No. NC version	Part No. igumid ESD
	15.025.R.0	15.025.R.0.NC	15.025.R.0.ESD
	Ready to ship in 24 - 48hrs.*	Ready to ship in 12 business days*	Ready to ship in 12 business days*▲

▲ ESD version - some series available from stock - further information and the complete product range ► From page 142
*Average time before the ordered goods are dispatched.

Order example | Order key and colour examples | Examples based on series 15

Order example for complete e-chain® (1.0m), colour black, with mounting brackets and interior separation:

e-chain® (1.0m)	Please indicate e-chain® length or number of links: 1.0m or 33 links	15.025.075.0
+ Mounting brackets	1 set (with tiwrap plates)	1025.34PZ
Interior separation	with 2 separators assembled every 2 nd link	2 x 154
Order text:	1m 15.025.075.0 + 1025.34PZ + 2 x 154	

Order key

e-chain® zip-open along the outer radius **15.025.075.0**
 e-tube zip-open along the outer radius **R15.025.075.0**

Series / Type

Width index (depends on **B**)

Bend radius **R**

Colour index (standard black)

Order index for colour options

Colour	Order index	Colour	Order index
Black	Standard .0	Orange	Special colour .2
Silver-grey	Special colour .31	Yellow	Special colour .4
White	Special colour .1	Light grey	Special colour .14
Grey-white	Special colour .1S		

Black e-chains® ready to ship in 24 - 48hrs.*
Above special colours upon request.

Fast opening, small pitch, smooth running

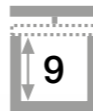

e-chains® | Series 047 | Crossbars on a strip - zip-open along the outer radius

Part No.	Bi	Ba	R Available bend radii	Weight
e-chains®	[mm]	[mm]	[mm]	[kg/m]
047.10.R.0	10	16	018 028 038	≈ 0.10
047.16.R.0	16	22	018 028 038	≈ 0.11

Complete Part No. with required radius (R). Example: 047.10.038.0

Installation dimensions

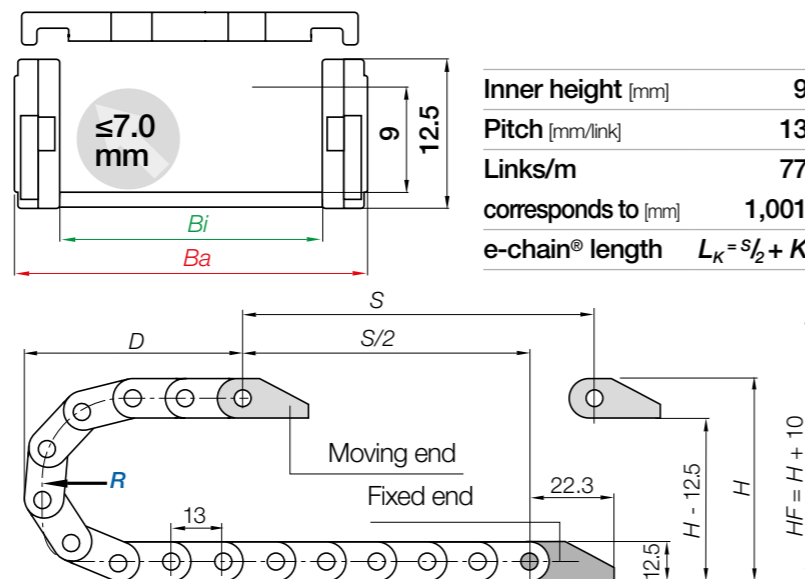
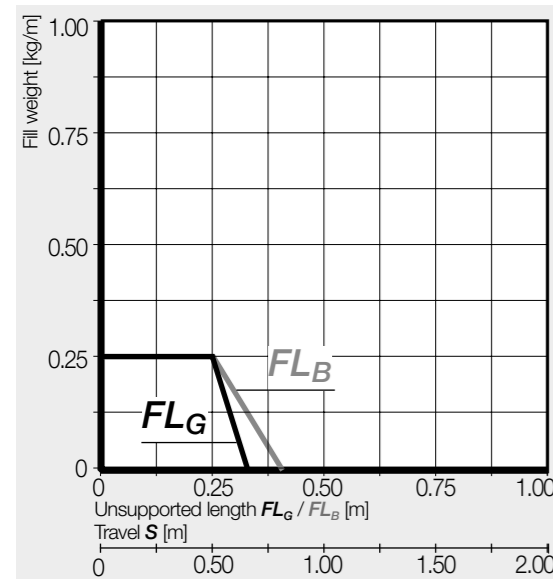

R	018	028	038
H	48.5	68.5	88.5
D	44	54	64
K	85	115	150

The required clearance height: $H_F = H + 10\text{mm}$ (with 0.2kg/m fill weight)

Mounting brackets, polymer one-piece | One end pivoting

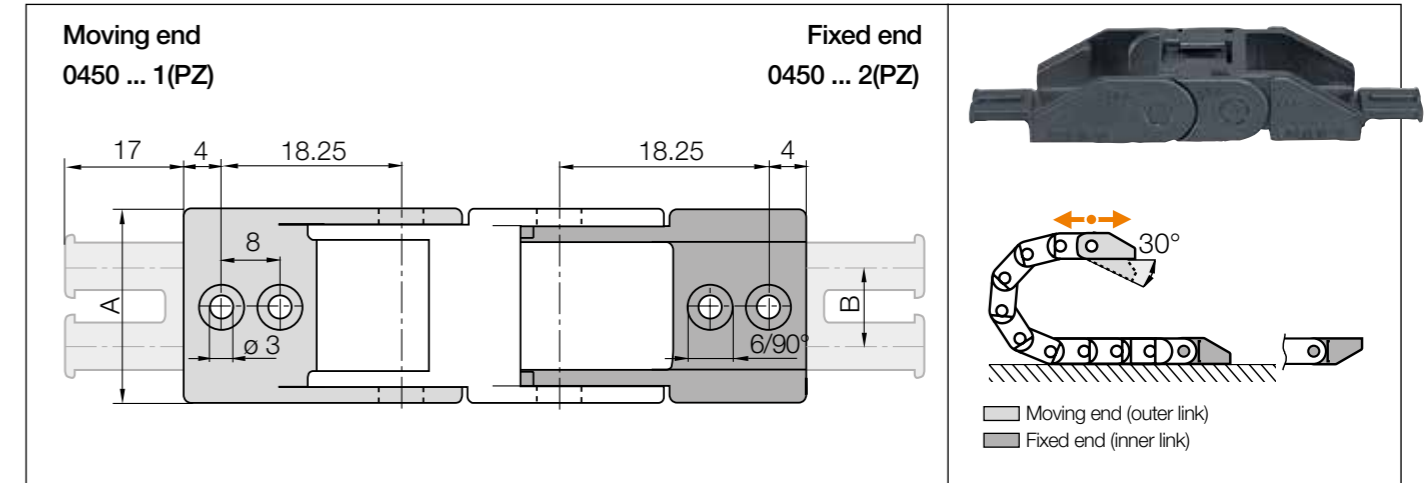

Width index	Part No. full set with tiewrap plates	Part No. full set without tiewrap plates	A [mm]	B [mm]	Number of teeth
10. ►	0450.10.12PZ	0450.10.12	16	-	1
16. ►	0450.16.12PZ	0450.16.12	22	10	2

Mounting bracket with strain relief tiewrap plate has reductions of $\phi 3\text{mm} / \phi 6\text{mm } 90^\circ$

Mounting bracket without strain relief tiewrap plate only has holes of $\phi 3\text{mm}$

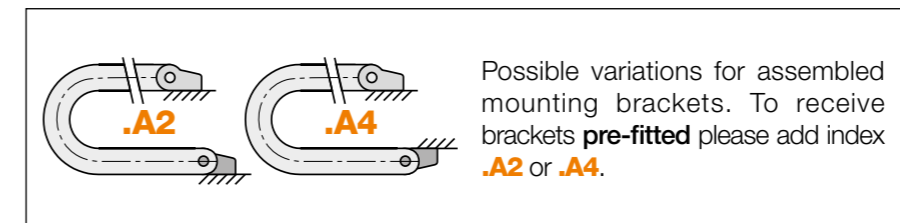

0450.10.12PZ.A2 Order example
 .A... to indicate option with brackets pre-fitted
 With integrated strain relief tiewrap plates
 Full set
 Series

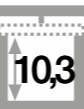

e-chains® | Series 07 | Crossbars on a strip - zip-open along the outer radius

Part No.	Bi	Ba	R Available bend radii				Weight
e-chains®	[mm]	[mm]	[mm]	[mm]	[mm]		[kg/m]
07.06.R.0	06	12.5	018	028	038	-	≈ 0.13
07.10.R.0▲	10	16.5	018	028	038	-	≈ 0.14
07.16.R.0▲	16	22.5	018	028	038	-	≈ 0.16
07.20.R.0▲	20	27	018	028	038	-	≈ 0.17
07.30.R.0▲	30	37	018	028	038	-	≈ 0.20
07.40.R.0▲	40	47	018	028	038	-	≈ 0.23
07.50.R.0▲	50	57	018	028	038	-	≈ 0.26
07.64.R.0	64	71	018	028	038	048	≈ 0.30

▲ ESD version (Electro Static Discharge) available from stock. More information ▶ From page 142

Complete Part No. with required radius (R). Example: 07.40.038.0

Installation dimensions

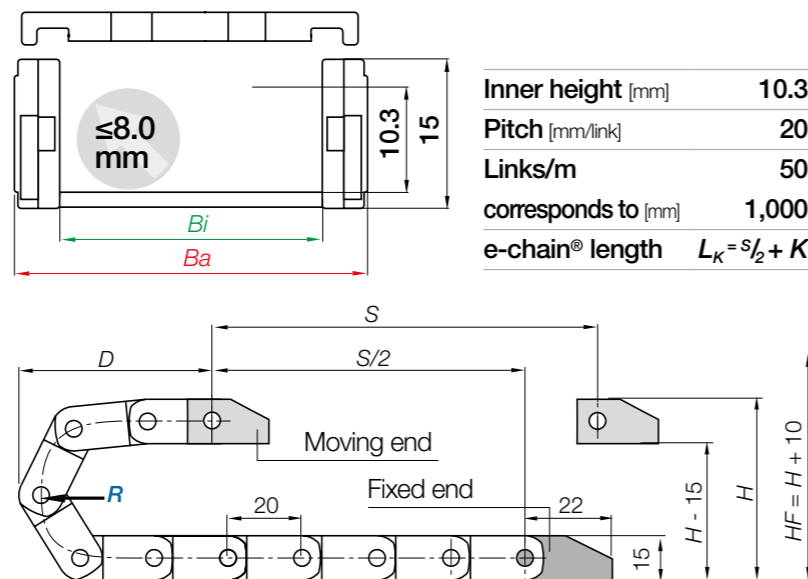
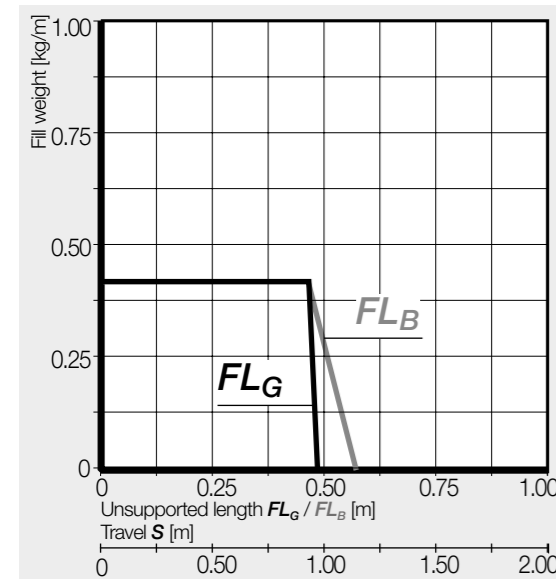

R	018	028	038	048*
H	51	71	91	111
D	56	66	76	86
K	100	130	160	195

The required clearance height: $H_F = H + 10\text{mm}$ (with 0.2kg/m fill weight)

*Radius 048 only for series 07.64

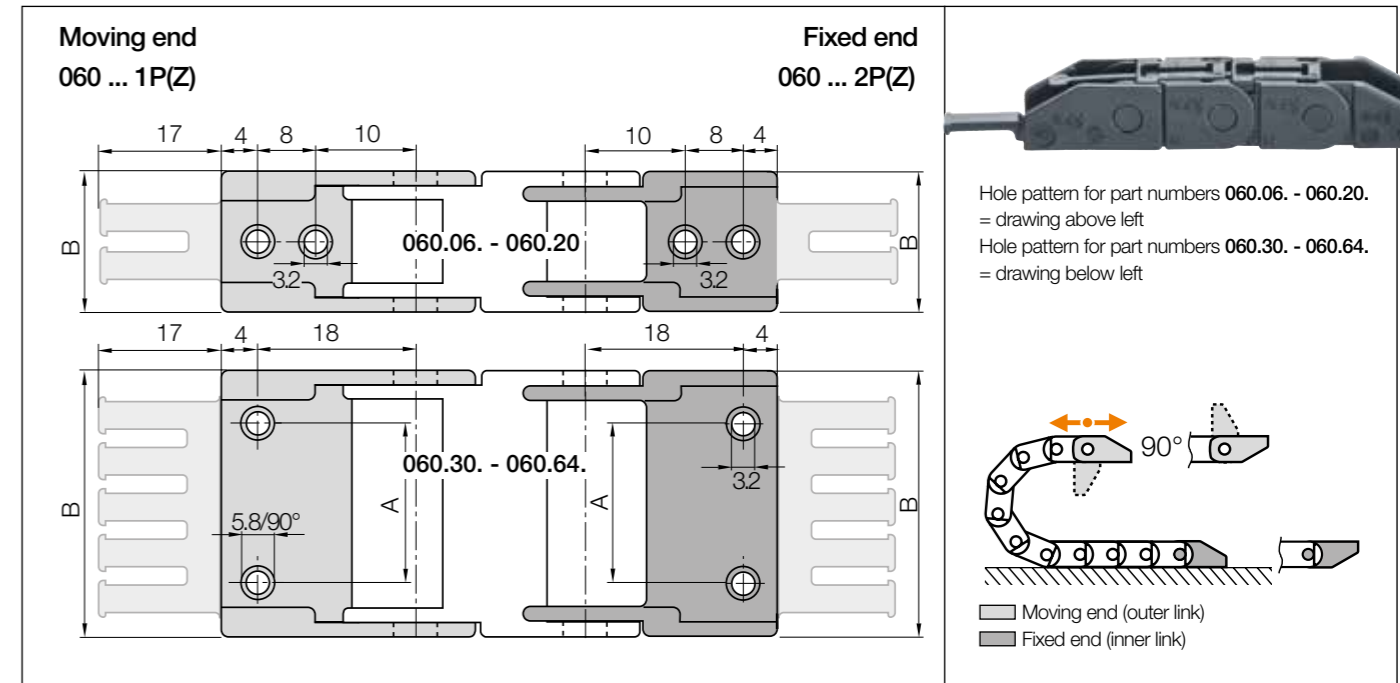

Width index	Part No. full set with tiewrap plates	Part No. full set without tiewrap plates	A [mm]	B [mm]	Number of teeth
06.	060.06.12PZ	060.06.12	-	12.5	1
10.	060.10.12PZ	060.10.12	-	16.5	1
16.	060.16.12PZ	060.16.12	-	22.5	2
20.	060.20.12PZ	060.20.12	-	27.0	2
30.	060.30.12PZ	060.30.12	22	37.0	3
40.	060.40.12PZ	060.40.12	32	47.0	4
50.	060.50.12PZ	060.50.12	42	57.0	5
64.	060.64.12PZ	060.64.12	56	71.0	6

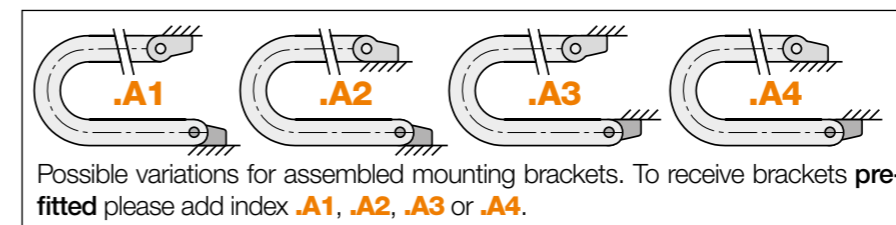

Possible variations for assembled mounting brackets. To receive brackets pre-fitted please add index .A1, .A2, .A3 or .A4.

060.40.12PZ.A1 Order example
 .A... to indicate option with brackets pre-fitted
 With integrated strain relief tiewrap plates
 Full set
 Series

ESD - many sizes from stock

- Standardised product made from igamid ESD
- ESD material tested for over 10 million cycles for the toughest requirements
- Short delivery times including mounting brackets and interior separation; 24hrs, from stock

More information and the complete product range

▶ From page 142 or at ▶ www.igus.eu/esd



Fast opening, enclosed zipper-band



e-tube | Series R07 | Lids on a strip - zip-open along the outer radius

Part No.	Bi	Ba	R Available bend radii	Weight
e-tubes	[mm]	[mm]	[mm]	[kg/m]
R07.10.R.0	10	16.5	038 048	≈ 0.16
R07.16.R.0	16	22.5	038 048	≈ 0.18
R07.20.R.0	20	27	038 048	≈ 0.19
R07.30.R.0	30	37	038 048	≈ 0.22
R07.40.R.0	40	47	038 048	≈ 0.25
R07.50.R.0	50	57	038 048	≈ 0.28

Complete Part No. with required radius (R). Example: R07.40.038.0

Installation dimensions

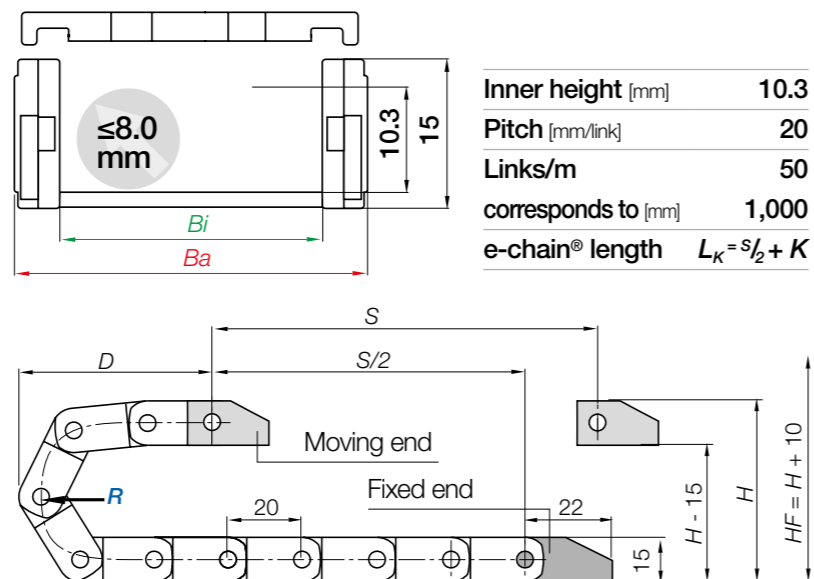
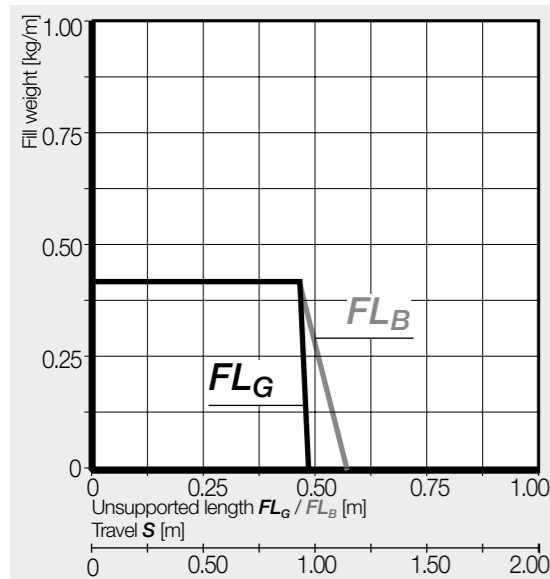

R	038	048
H	91	111
D	76	86
K	160	195

The required clearance height: $H_F = H + 10\text{mm}$ (with 0.2kg/m fill weight)

Mounting brackets, polymer one-piece | Locking

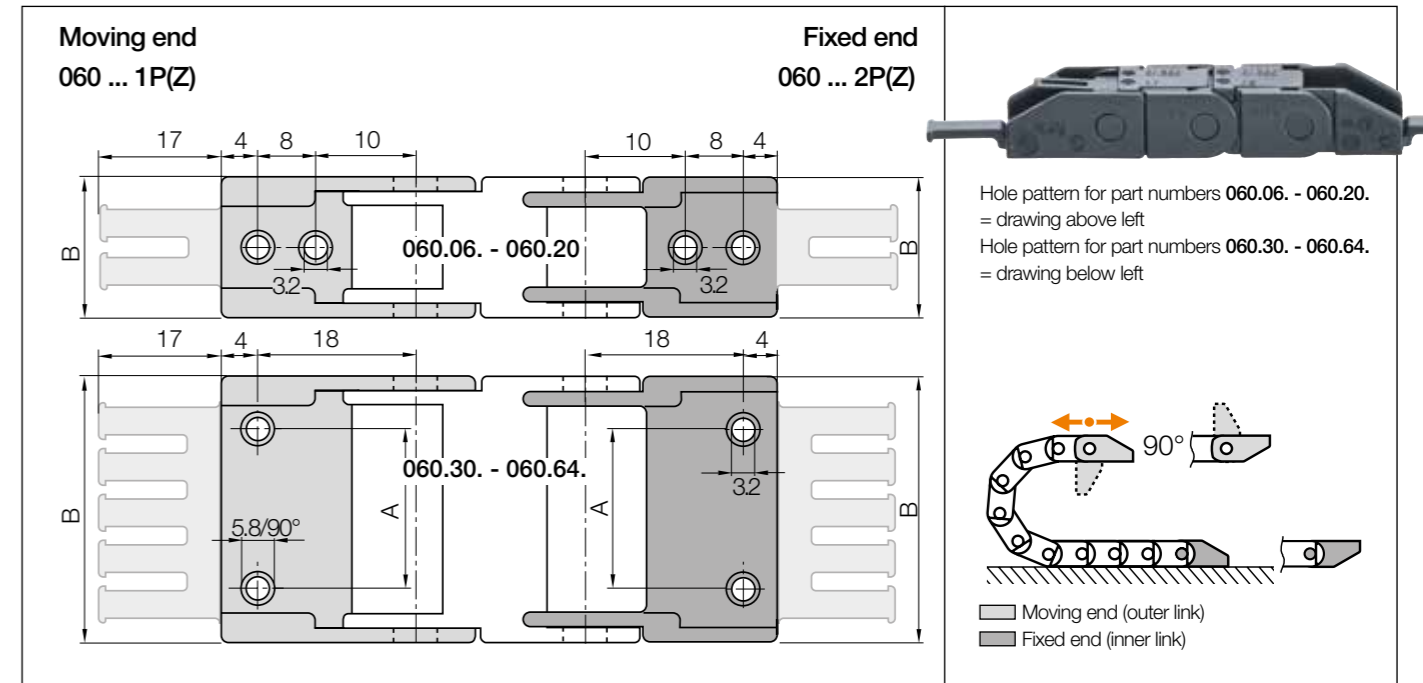

Width index	Part No. full set with tiwrap plates	Part No. full set without tiwrap plates	A [mm]	B [mm]	Number of teeth
10.	060.10.12PZ	060.10.12	-	16.5	1
16.	060.16.12PZ	060.16.12	-	22.5	2
20.	060.20.12PZ	060.20.12	-	27.0	2
30.	060.30.12PZ	060.30.12	22	37.0	3
40.	060.40.12PZ	060.40.12	32	47.0	4
50.	060.50.12PZ	060.50.12	42	57.0	5

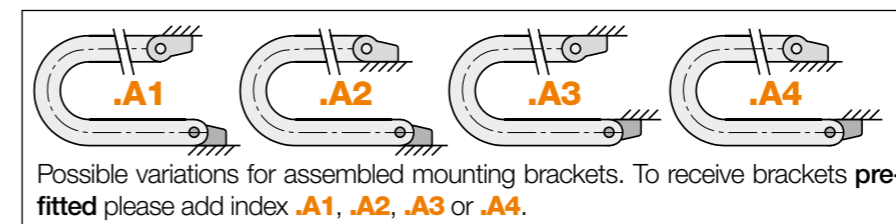

060.40.12PZ.A1 Order example
 .A... to indicate option with brackets pre-fitted
 With integrated strain relief tiwrap plates
 Full set
 Series

Possible variations for assembled mounting brackets. To receive brackets pre-fitted please add index .A1, .A2, .A3 or .A4.

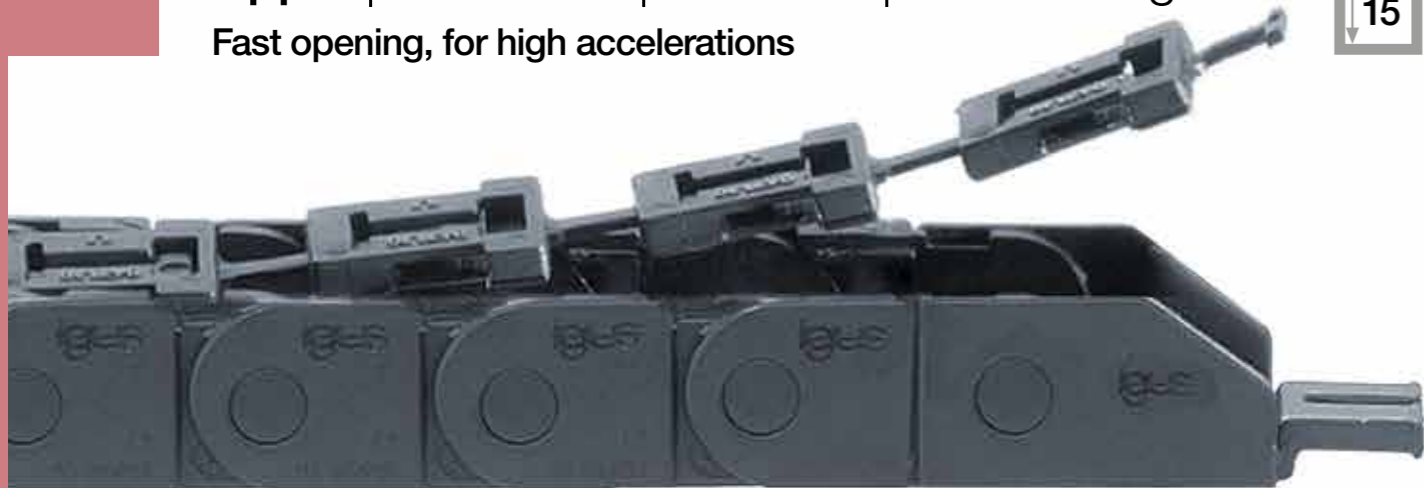
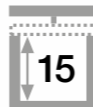

e-chains® | Series 09 | Crossbars on a strip - zip-open along the outer radius

Part No.	Bi	Ba	R Available bend radii	Weight
e-chains®	[mm]	[mm]	[mm]	[kg/m]
09.10 .R.0	10	18.2	028 038 048	≈ 0.21
09.16 .R.0▲	16	24.2	028 038 048	≈ 0.24
09.20 .R.0▲	20	28.2	028 038 048	≈ 0.25
09.30 .R.0▲	30	38.2	028 038 048	≈ 0.28
09.40 .R.0▲	40	48.2	028 038 048	≈ 0.31
09.50 .R.0▲	50	58.2	028 038 048	≈ 0.34
09.64 .R.0	64	72.2	028 038 048	≈ 0.39

▲ ESD version (Electro Static Discharge) available from stock. More information ▶ From page 142

Complete Part No. with required radius (R). Example: 09.40.038.0

Installation dimensions

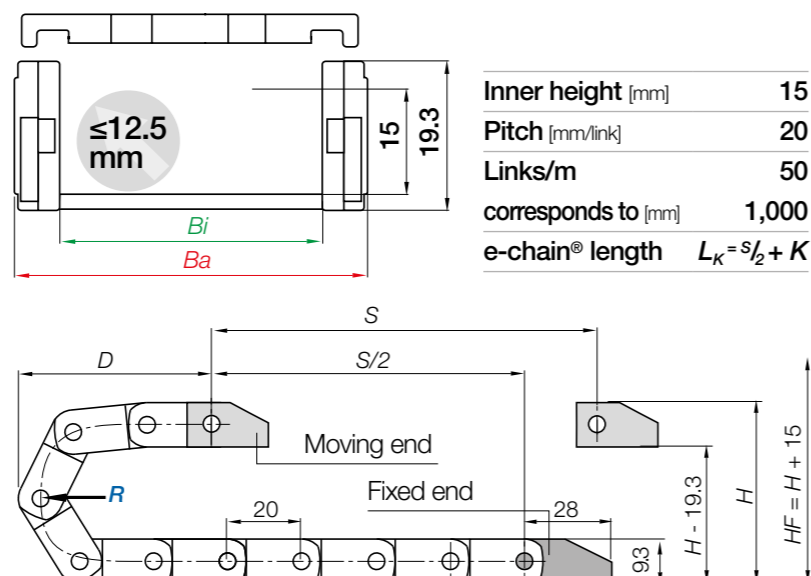
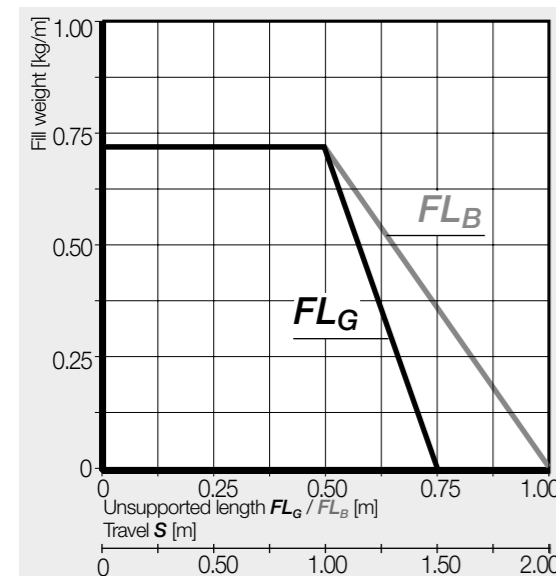

R	028	038	048
H	75	95	115
D	68	78	88
K	130	160	195

The required clearance height: $H_F = H + 15\text{mm}$ (with 0.3kg/m fill weight)

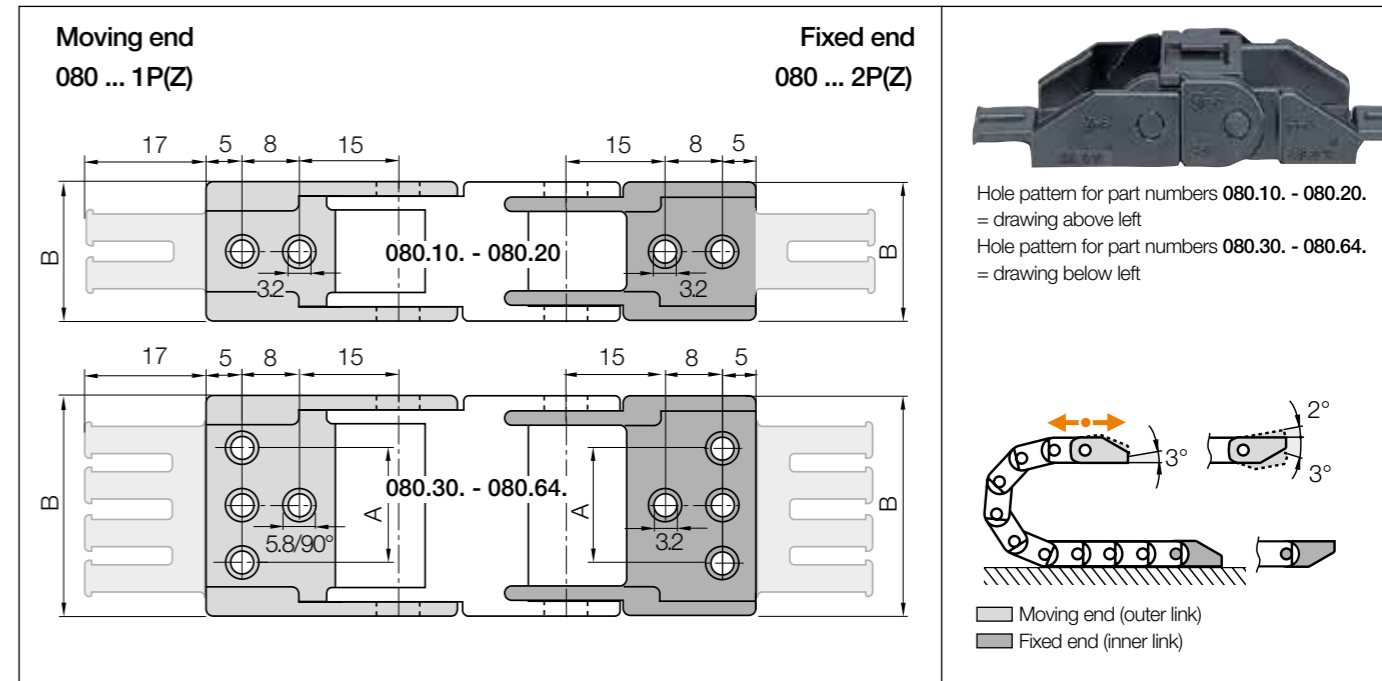

Width index	Part No. full set with tiewrap plates	Part No. full set without tiewrap plates	A [mm]	B [mm]	Number of teeth
10. ▶	080.10.12PZ	080.10.12	-	18.2	1
16. ▶	080.16.12PZ	080.16.12	-	24.2	2
20. ▶	080.20.12PZ	080.20.12	-	28.2	2
30. ▶	080.30.12PZ	080.30.12	22	38.2	3
40. ▶	080.40.12PZ	080.40.12	32	48.2	4
50. ▶	080.50.12PZ	080.50.12	42	58.2	5
64. ▶	080.64.12PZ	-	56	72.2	6

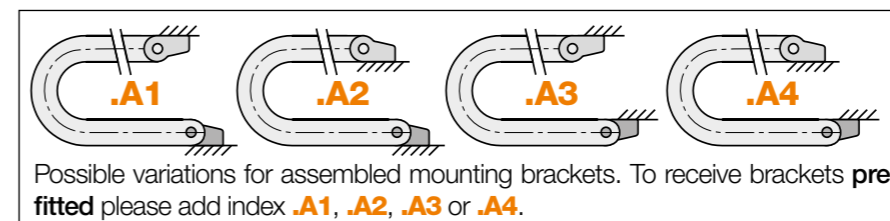

080.40.12PZ.A1 Order example
 .A... to indicate option with brackets pre-fitted
 With integrated strain relief tiewrap plates
 Full set
 Series

ESD - many sizes from stock

- Standardised product made from igumid ESD
- ESD material tested for over 10 million cycles for the toughest requirements
- Short delivery times including mounting brackets and interior separation; 24hrs, from stock

More information and the complete product range

▶ From page 142 or at ▶ www.igus.eu/esd



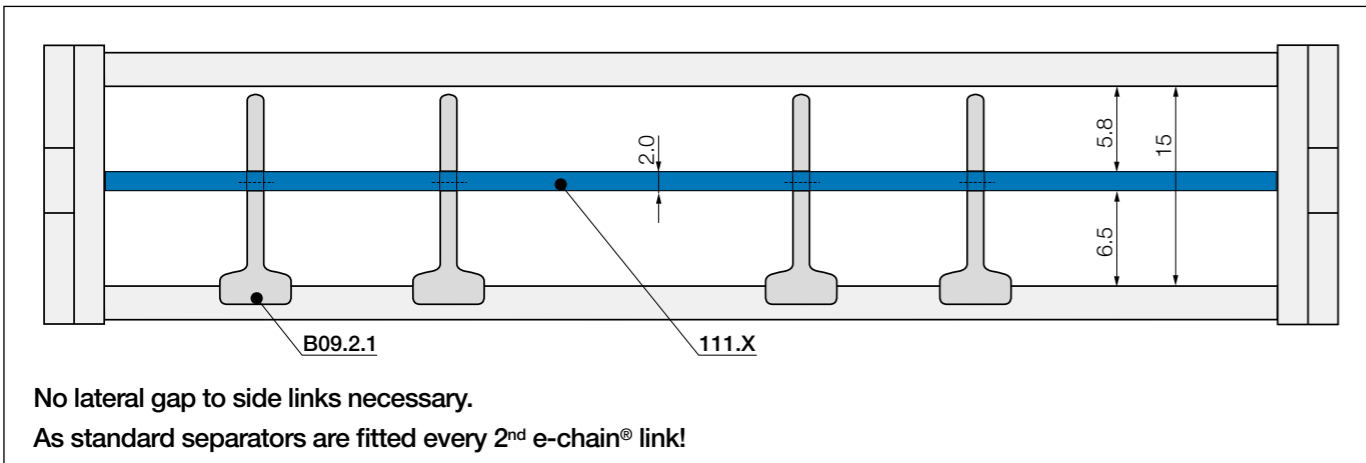

		Slotted separator unassembled B09.2 assembled B09.2.1
--	--	--

Slotted separator
 Vertical separation. The slot allows basic vertical/horizontal shelving arrangements.

		Full-width shelf for e-chains® unassembled 110.X assembled 111.X
--	--	---

Full-width shelf
 This option is for applications with many small cables with similar diameters. For full-width separation.

Full-width shelves Width = X [mm]	X [mm]	unassembled	assembled	X [mm]	unassembled	assembled	X [mm]	unassembled	assembled
		016	110.16	111.16	030	110.30	111.30	050	110.50
	020	110.20	111.20	040	110.40	111.40			

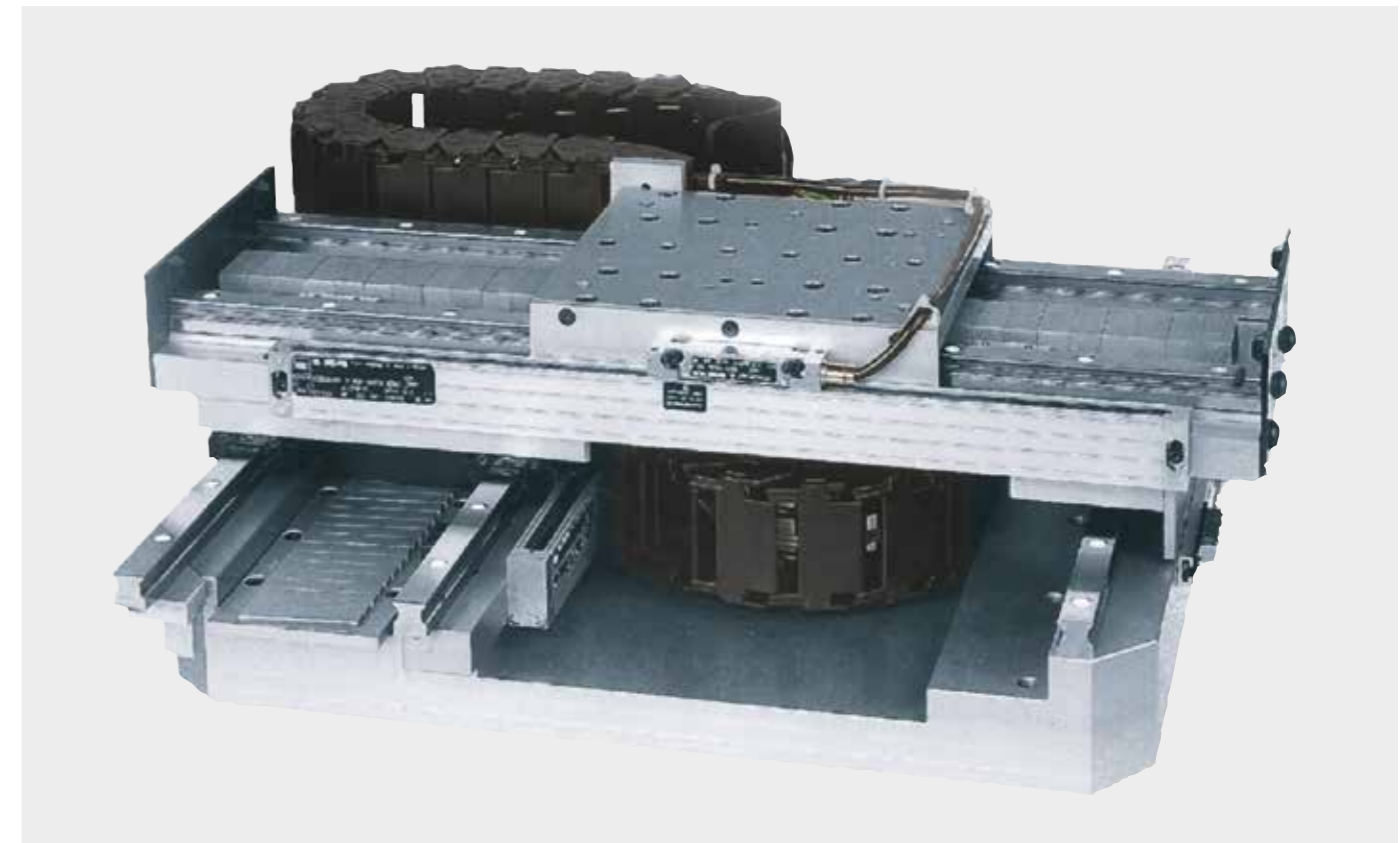

igus® zipper e-chain® on an X/Y unit. Acceleration: 100m/s²

Fast opening, enclosed zipper-band

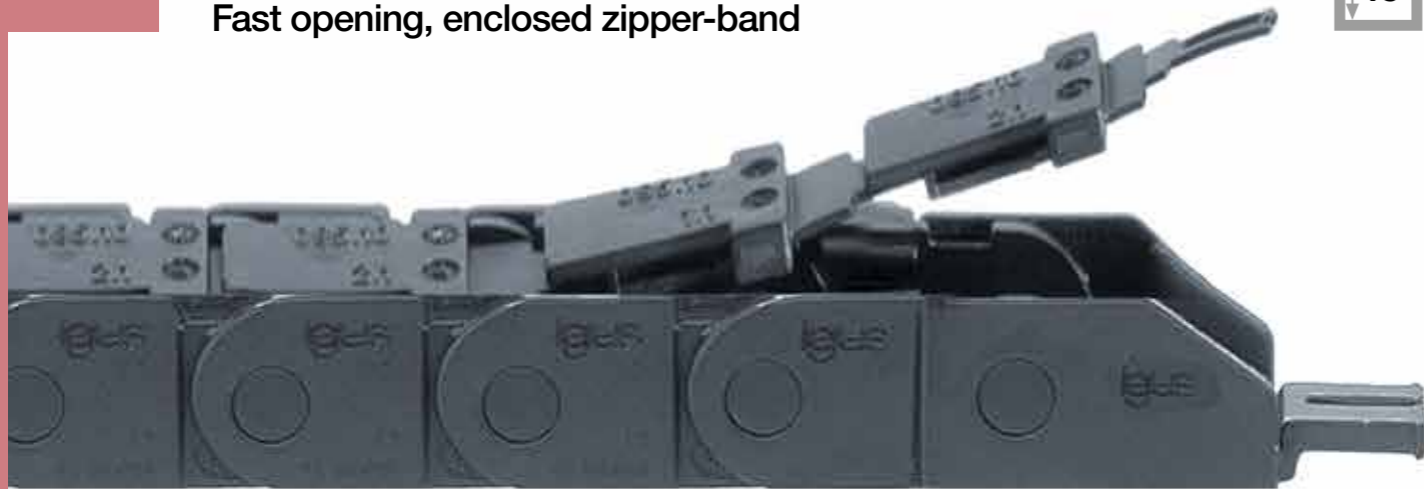
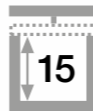

e-tube | Series R09 | Lids on a strip - zip-open along the outer radius

Part No. e-tubes	<i>Bi</i>	<i>Ba</i>	<i>R</i> Available bend radii			Weight [kg/m]
	[mm]	[mm]	[mm]	[mm]	[mm]	
R09.10.R.0	10	18.2	048	075	100	≈ 0.23
R09.16.R.0	16	24.2	048	075	100	≈ 0.26
R09.20.R.0	20	28.2	048	075	100	≈ 0.27
R09.30.R.0	30	38.2	048	075	100	≈ 0.30
R09.40.R.0	40	48.2	048	075	100	≈ 0.33
R09.50.R.0	50	58.2	048	075	100	≈ 0.36

Complete Part No. with required radius (*R*). Example: R09.40.048.0

Installation dimensions

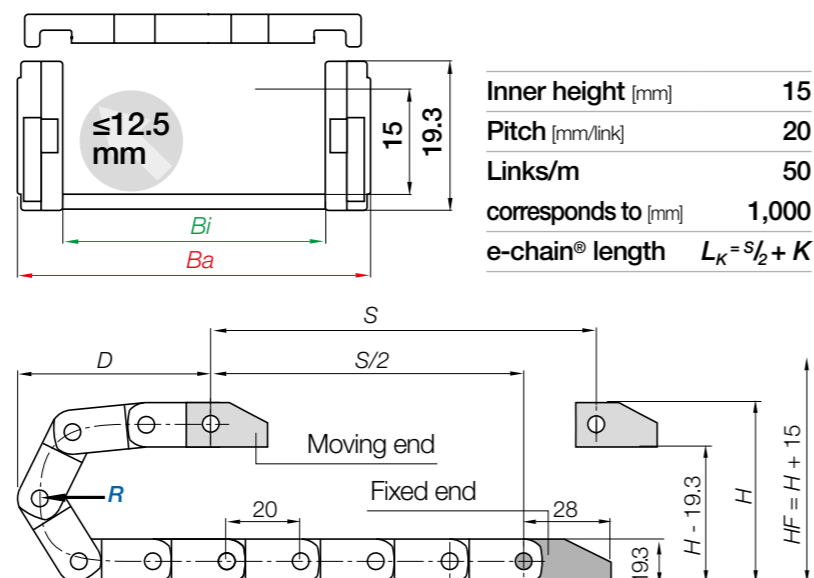
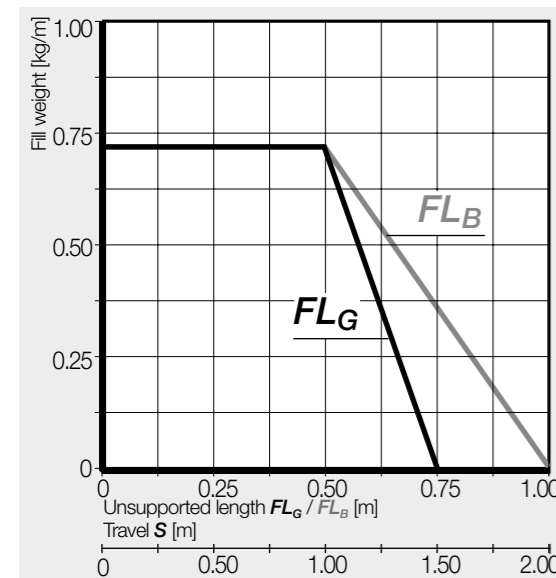

<i>R</i>	048	075	100
<i>H</i>	115	169	219
<i>D</i>	88	115	140
<i>K</i>	195	280	355

The required clearance height: $H_F = H + 15\text{mm}$ (with 0.3kg/m fill weight)

Mounting brackets, polymer one-piece | Locking

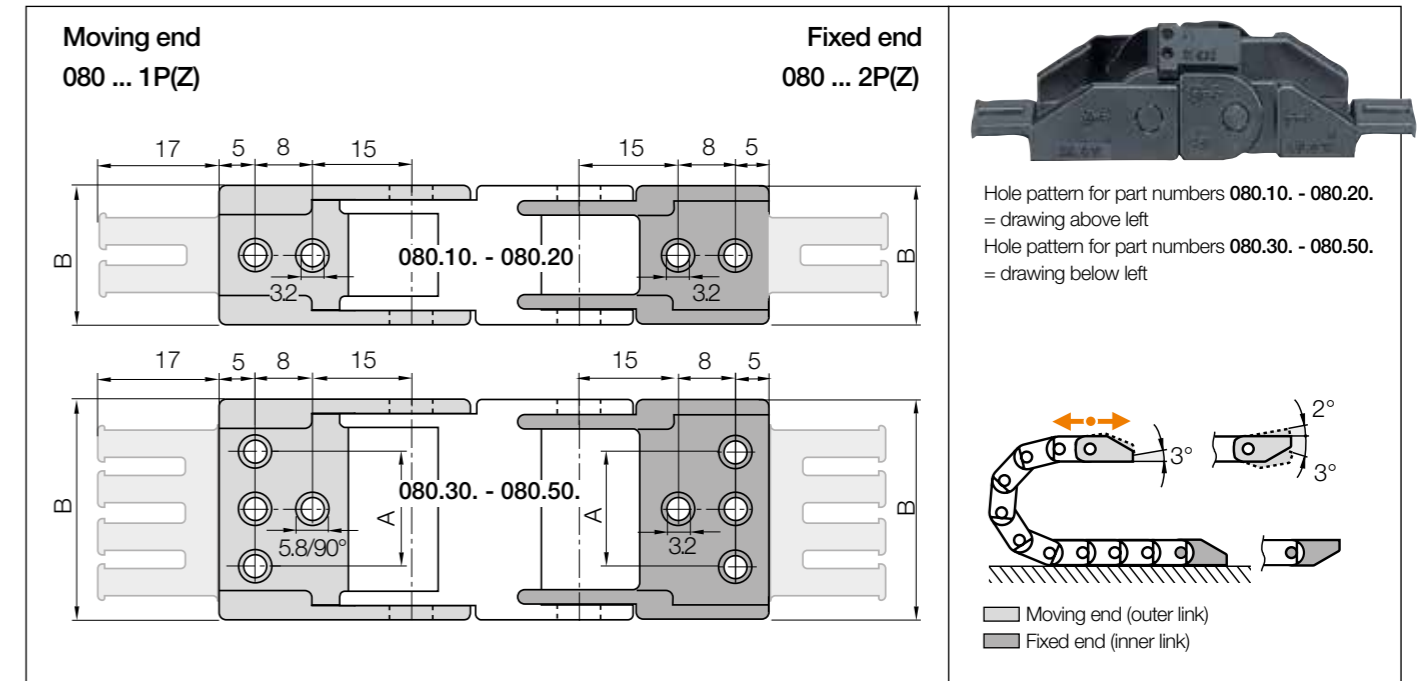

Width index	Standard	Part No. full set with tiewrap plates	Part No. full set without tiewrap plates	<i>A</i> [mm]	<i>B</i> [mm]	Number of teeth
10.	▶	080.10.12PZ	080.10.12	-	18.2	1
16.	▶	080.16.12PZ	080.16.12	-	24.2	2
20.	▶	080.20.12PZ	080.20.12	-	28.2	2
30.	▶	080.30.12PZ	080.30.12	22	38.2	3
40.	▶	080.40.12PZ	080.40.12	32	48.2	4
50.	▶	080.50.12PZ	080.50.12	42	58.2	5

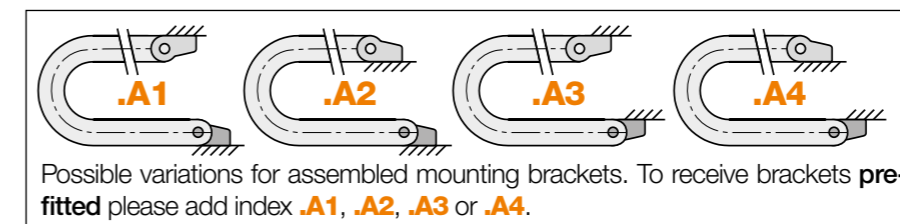

080.40.12PZ.A1 Order example
 .A... to indicate option with brackets pre-fitted
 With integrated strain relief tiewrap plates
 Full set
 Series



e-chains® | Series 15 | Crossbars on a strip - zip-open along the outer radius

Part No.	Bi	Ba	R Available bend radii									Weight
			[mm]	[mm]	[mm]	[mm]	[mm]	[mm]	[mm]	[mm]	[mm]	
15.015.R.0	15	26	038	048	075	100	110	125	145	180	≈ 0.35	
15.025.R.0	25	36	038	048	075	100	110	125	145	180	≈ 0.40	
15.038.R.0	38	49	038	048	075	100	110	125	145	180	≈ 0.46	
15.050.R.0	50	61	038	048	075	100	110	125	145	180	≈ 0.52	
15.5 .R.0	63	76	038	048	075	100	110	125	145	180	≈ 0.63	
15.6 .R.0	80	94	038	048	075	100	110	125	145	180	≈ 0.70	
15.7 .R.0	100	113	038	048	075	100	110	125	145	180	≈ 0.76	

Before using this series on long travels please consult igus®.

Complete Part No. with required radius (R). Example: 15.025.038.0

Installation dimensions

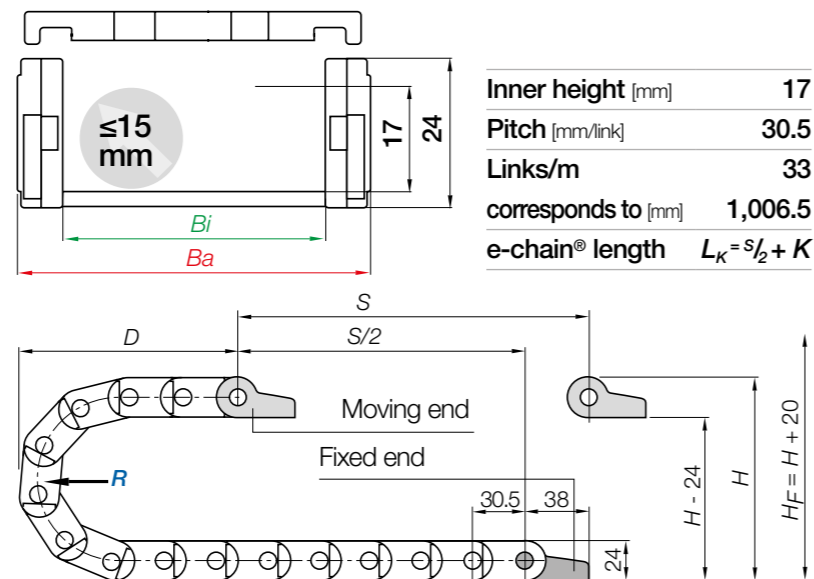
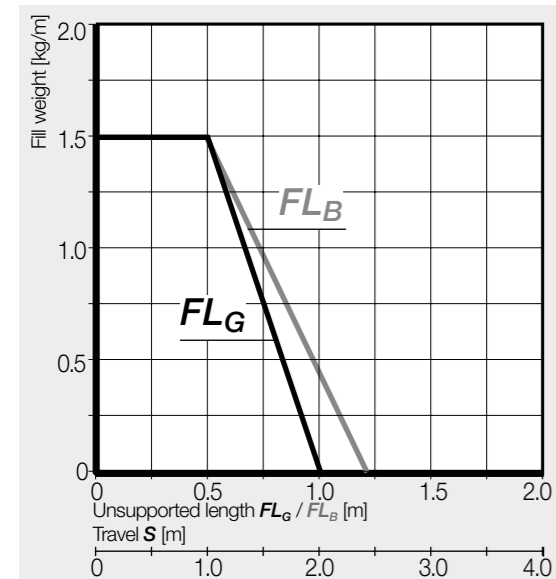

R	038	048	075	100	110	125	145	180
H	99	119	173	223	243	273	313	383
D	95	105	132	157	167	182	202	237
K	185	215	300	380	410	455	520	630

The required clearance height: $H_F = H + 20\text{mm}$ (with 1.0kg/m fill weight)

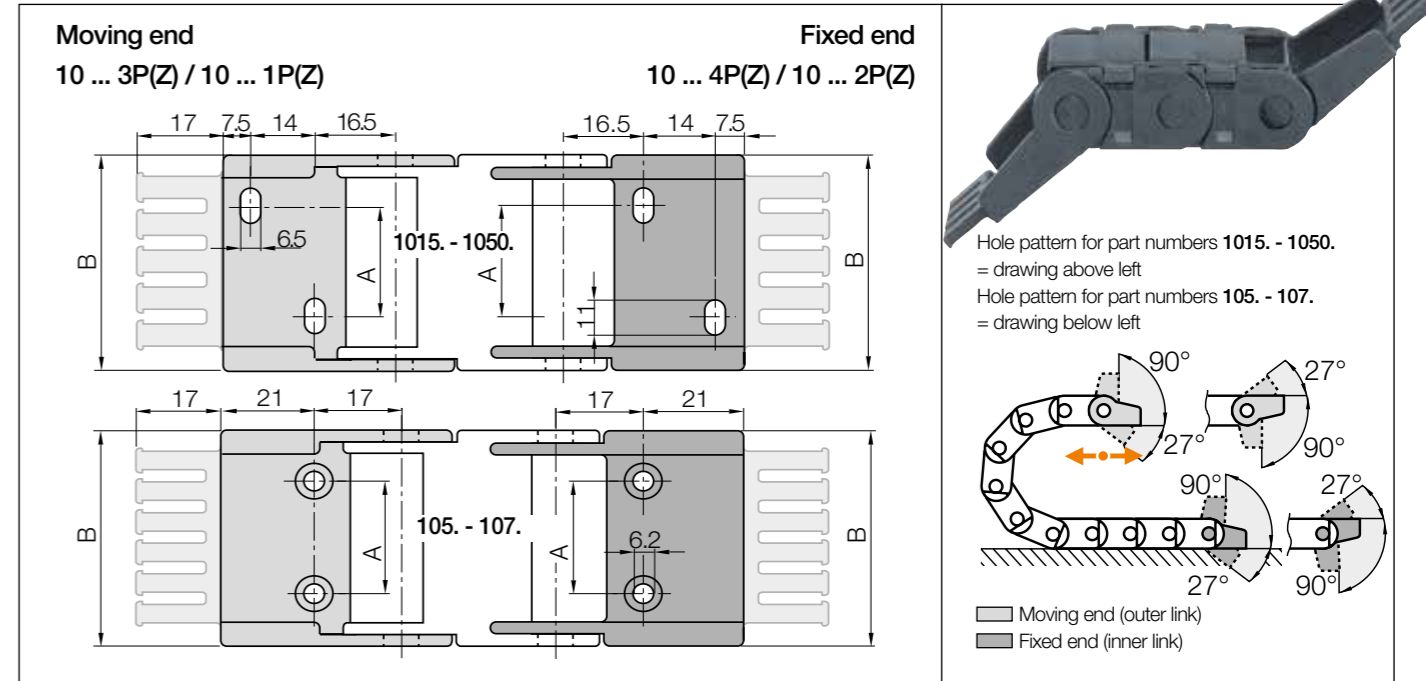

Width index	Standard	Part No. full set pivoting		Part No. full set locking		A [mm]	B [mm]	Number of teeth
		with tiewrap plates	without tiewrap plate	with tiewrap plates	without tiewrap plate			
015.	►	1015.34PZ	1015.34P	1015.12PZ	1015.12P	-	25.5	2
025.	►	1025.34PZ	1025.34P	1025.12PZ	1025.12P	10	35.5	3
038.	►	1038.34PZ	1038.34P	1038.12PZ	1038.12P	23	48.5	4
050.	►	1050.34PZ	1050.34P	1050.12PZ	1050.12P	35	60.5	5
5.	►	105. 34PZ	105. 34P	105. 12PZ	105. 12P	48	75.0	6
6.	►	106. 34PZ	106. 34P	106. 12PZ	106. 12P	65	92.0	8
7.	►	107. 34PZ	107. 34P	107. 12PZ	107. 12P	85	112.0	10

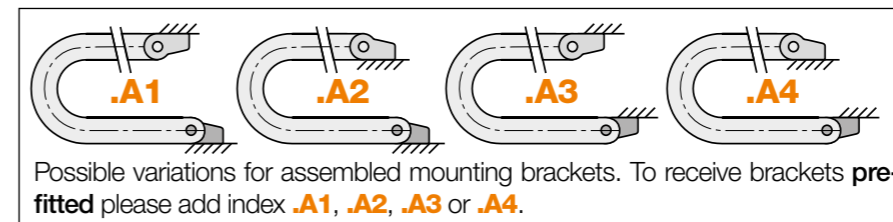

Possible variations for assembled mounting brackets. To receive brackets pre-fitted please add index .A1, .A2, .A3 or .A4.

1025.34PZ.A1 Order example
 .A... to indicate option with brackets pre-fitted
 With integrated strain relief tiewrap plates
 Full set
 Series

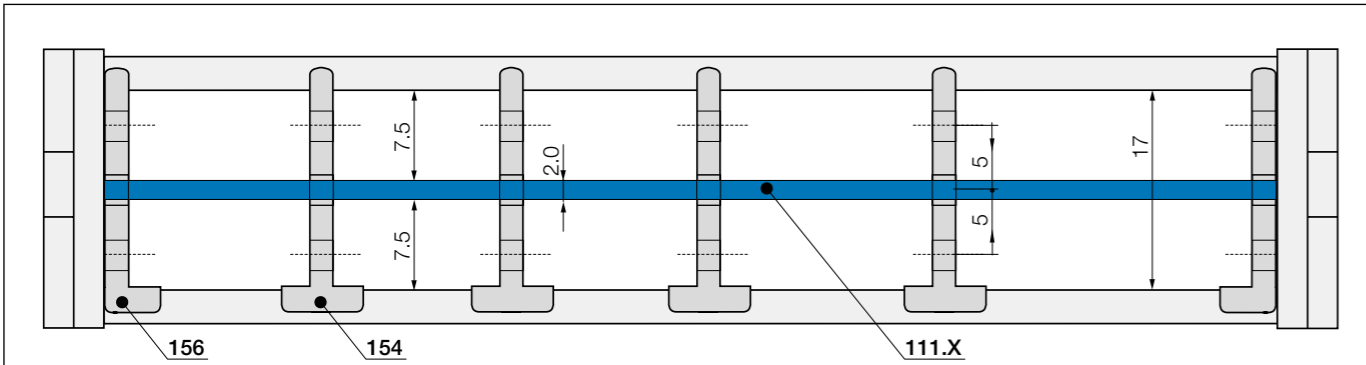

No lateral gap to side links necessary.
As standard separators are fitted every 2nd e-chain® link!

		Slotted separator unassembled 153 assembled 154
--	--	--

Slotted separator
Vertical separation. The slot allows basic vertical/horizontal shelving arrangements.

		Slotted side plate unassembled 155 assembled 156
--	--	---

Slotted side plate
Allows modular shelving right up to the side links. No clearance required!

		Full-width shelf for e-chains® unassembled 110.X assembled 111.X
--	--	---

Full-width shelf
This option is for applications with many small cables with similar diameters. For full-width separation.

Full-width shelves Width = X [mm]	X [mm]		X [mm]		X [mm]			
	unassembled	assembled	unassembled	assembled	unassembled	assembled		
015	110.15	111.15	050	110.50	111.50	100	110.100	111.100
025	110.25	111.25	063	110.63	111.63			
038	110.38	111.38	080	110.80	111.80			



igus® zipper e-chain® series 15 in a special purpose machine for quick cable installation

Fast opening, enclosed zipper-band

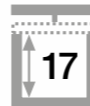

e-tube | Series R15 | Lids on a strip - zip-open along the outer radius

Part No.	Bi	Ba	R Available bend radii								Weight
			[mm]	[mm]	[mm]	[mm]	[mm]	[mm]	[mm]	[mm]	
R15.025.R.0	25	36	063	075	100	110	125	145	180	≈ 0.45	
R15.038.R.0	38	49	063	075	100	110	125	145	180	≈ 0.51	
R15.063.R.0	63	76	063	075	100	110	125	145	180	≈ 0.68	
R15.080.R.0	80	94	063	075	100	110	125	145	180	≈ 0.75	

Before using this series on long travels please consult igus®.

Complete Part No. with required radius (R). Example: R15.025.063.0

Installation dimensions

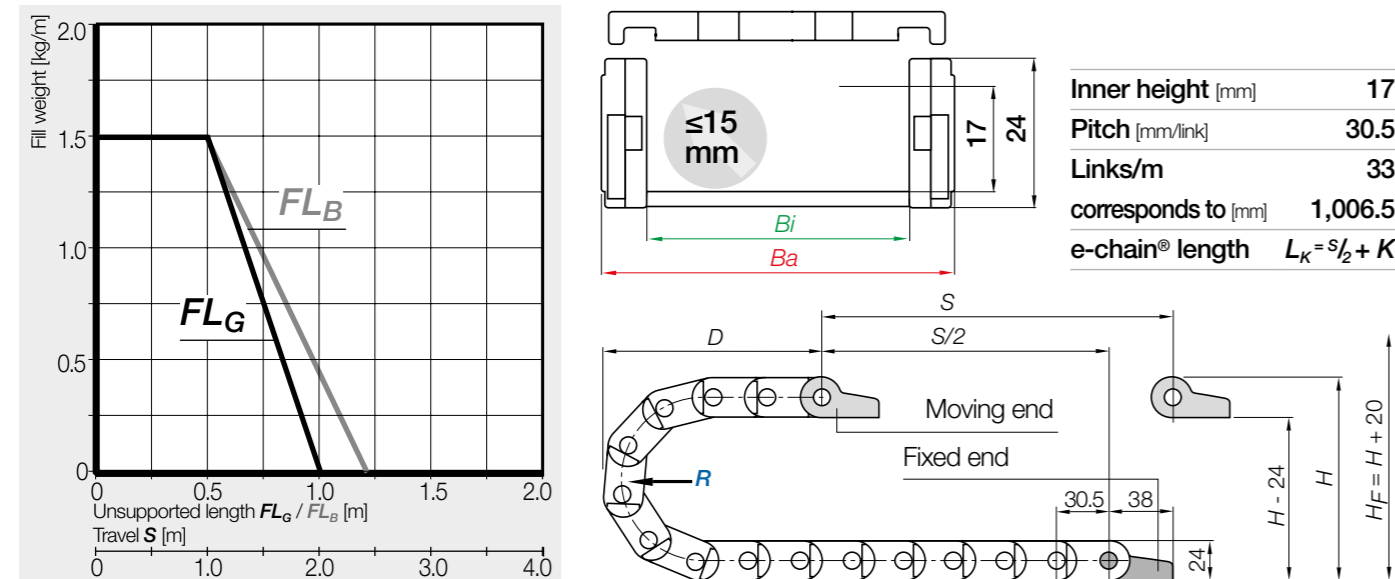

R	063	075	100	110	125	145	180	180
H	149	173	223	243	273	313	383	383
D	120	132	157	167	182	202	237	237
K	260	300	380	410	455	520	630	630

The required clearance height: $H_F = H + 20\text{mm}$ (with 1.0kg/m fill weight)

Mounting brackets, polymer one-piece | Pivoting | Locking

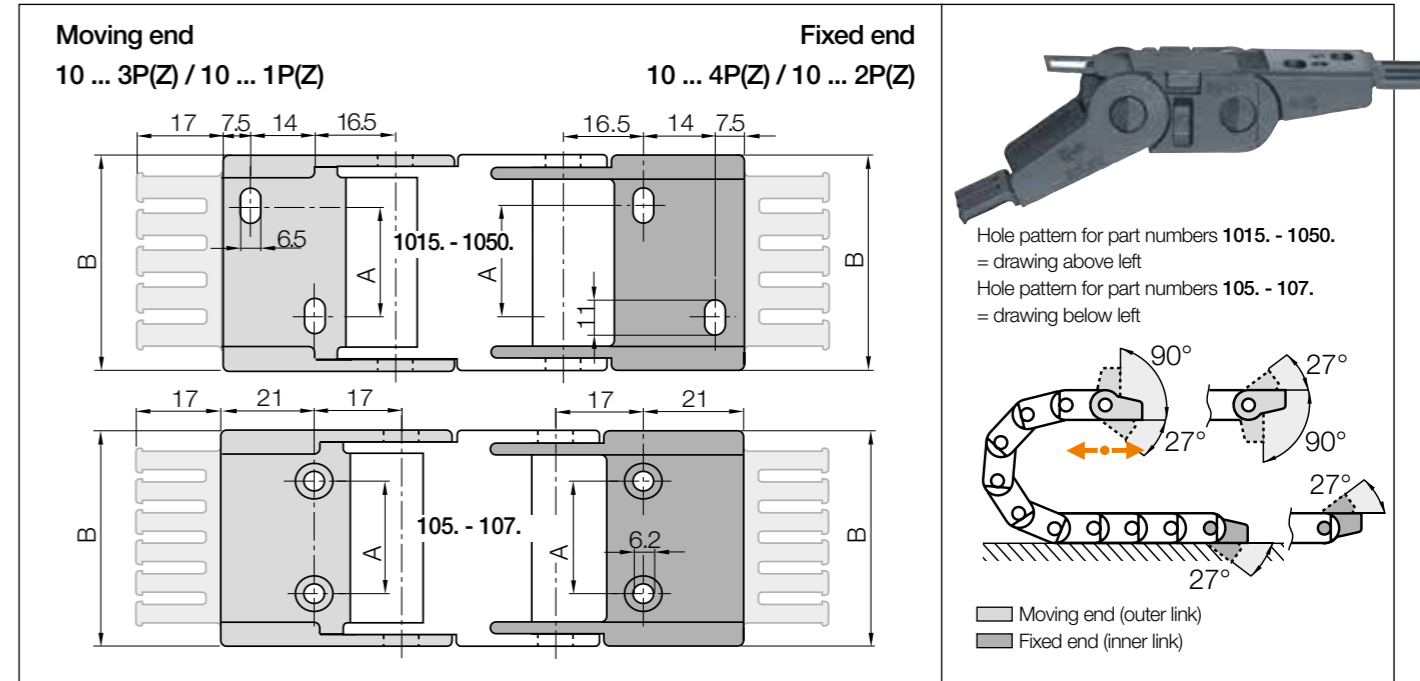
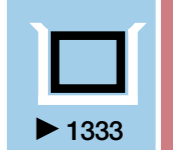

Width index	Part No. full set pivoting with tie-wrap plates	Part No. full set locking without tie-wrap plate	Part No. full set locking with tie-wrap plates	Part No. full set locking without tie-wrap plate	A [mm]	B [mm]	Number of teeth
038. ►	1038.34PZ	1038.34P	1038.12PZ	1038.12P	23	48.5	4
063. ►	105. 34PZ	105. 34P	105. 12PZ	105. 12P	48	75.0	6
080. ►	106. 34PZ	106. 34P	106. 12PZ	106. 12P	65	92.0	8

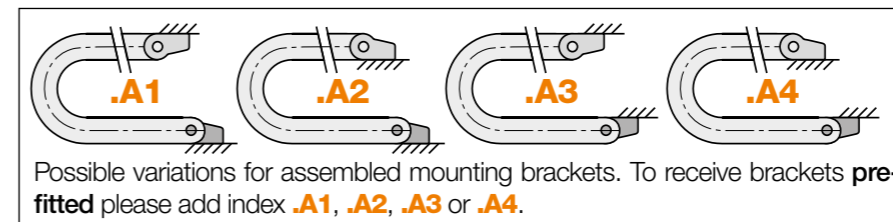

1025.34PZ.A1 Order example
 .A... to indicate option with brackets pre-fitted
 With integrated strain relief tie-wrap plates
 Full set
 Series

Interior separation

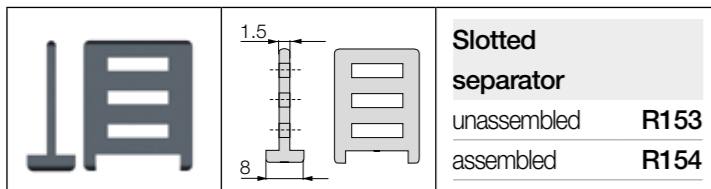
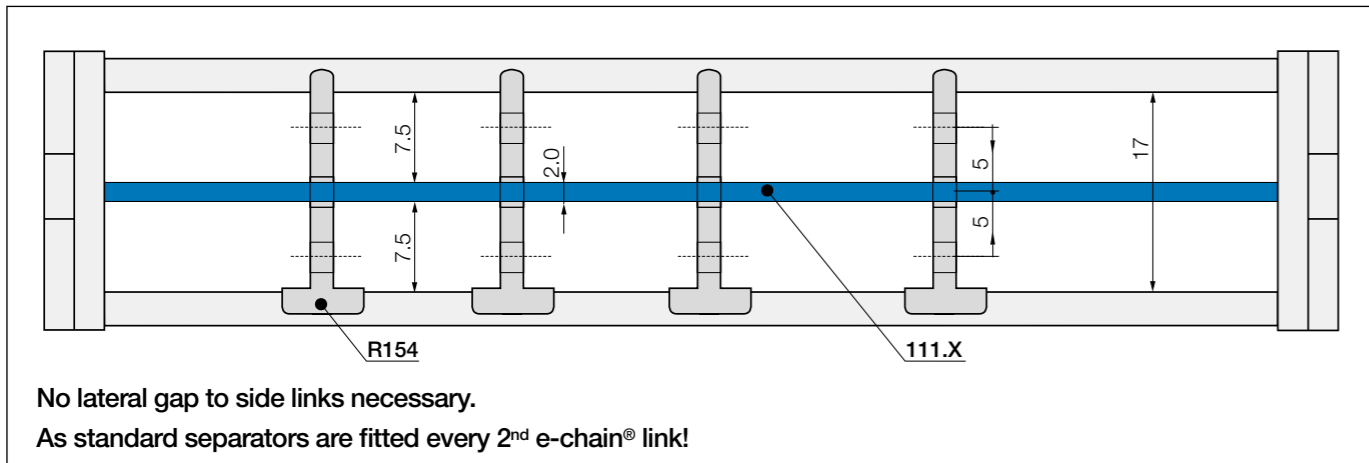
**Slotted separator**

Vertical separation in e-tubes. The slot allows basic vertical/horizontal shelving arrangements.

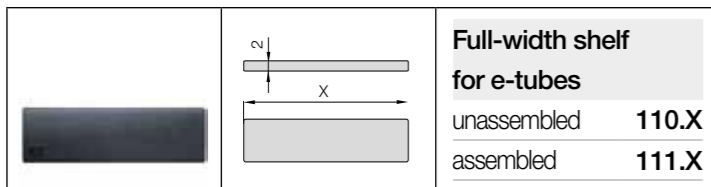
**Full-width shelf**

This option is for applications with many small cables with similar diameters. For full-width separation.

Full-width shelves

Width = X [mm]

X [mm]	unassembled	assembled	X [mm]	unassembled	assembled
025	110.25	111.25	063	110.63	111.63
038	110.38	111.38	080	110.80	111.80

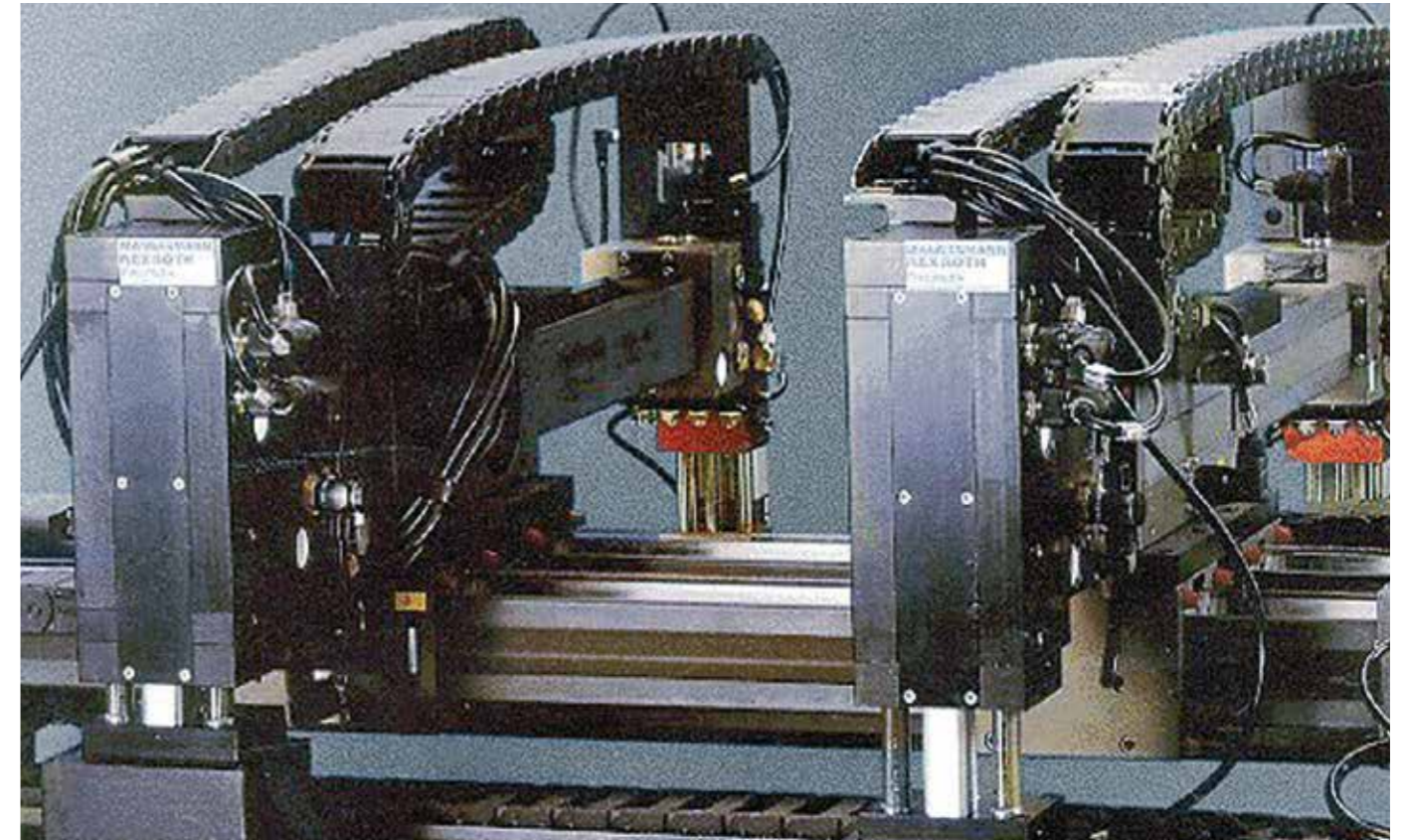

Series 15 on a pick and place machine. Acceleration: 100 m/s², smooth running

Fast opening, large inner height

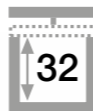

e-chains® | Series 17 | Crossbars on a strip - zip-open along the outer radius

Part No. e-chains®	<i>Bi</i>	<i>Ba</i>	<i>R</i> Available bend radii				Weight [kg/m]
	[mm]	[mm]	[mm]	[mm]	[mm]	[mm]	
17.1.R.0	15	25.5	063	075	100	125	≈ 0.52
17.2.R.0	25	35.5	063	075	100	125	≈ 0.59
17.3.R.0	38	48.5	063	075	100	125	≈ 0.65
17.4.R.0	50	60.5	063	075	100	125	≈ 0.70
17.5.R.0	63	76	063	075	100	125	≈ 0.83
17.6.R.0	80	93	063	075	100	125	≈ 0.92
17.7.R.0	100	113	063	075	100	125	≈ 1.06

Complete Part No. with required radius (*R*). Example: 17.2.075.0

Installation dimensions

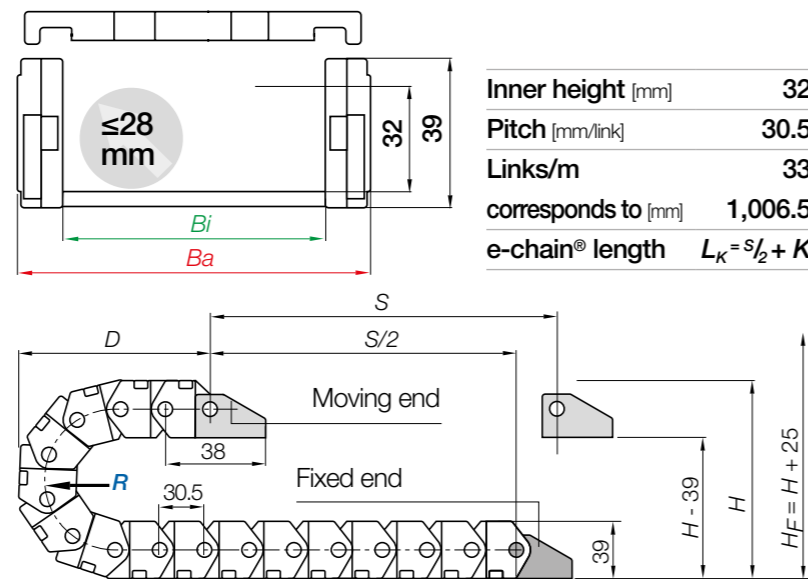
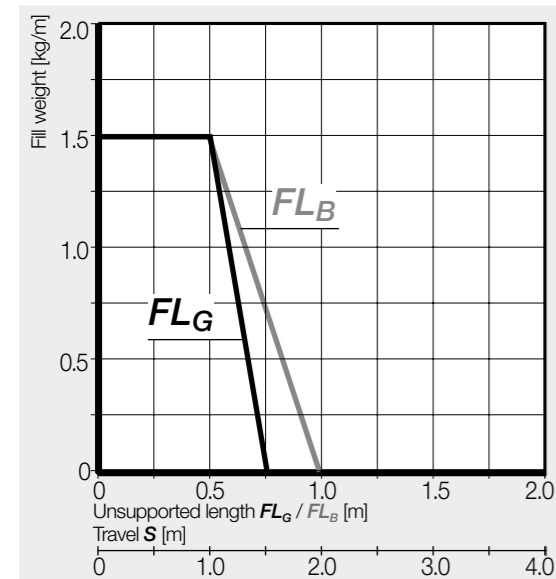

<i>R</i>	063	075	100	125
<i>H</i>	165	189	239	289
<i>D</i>	128	140	165	190
<i>K</i>	260	300	380	455

The required clearance height: $H_F = H + 25\text{mm}$ (with 1.5kg/m fill weight)

Mounting brackets, polymer one-piece | Locking

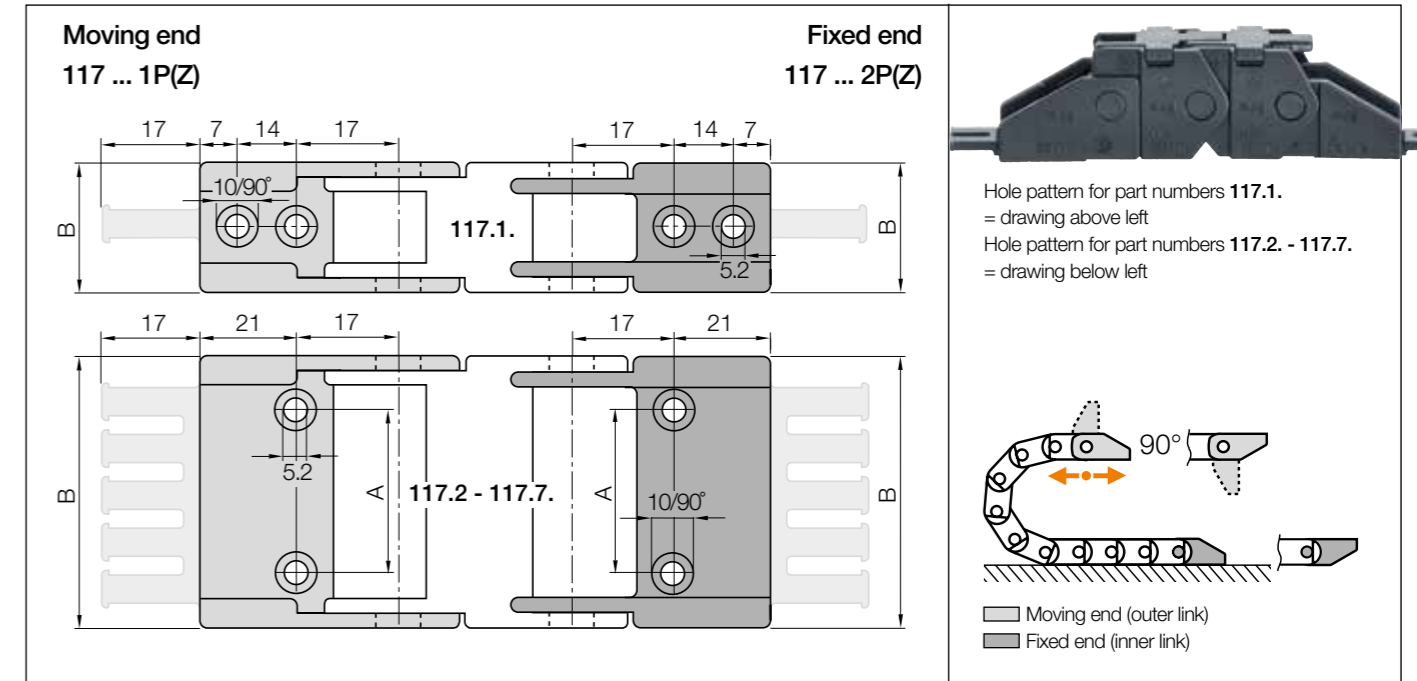

Width index	Part No. full set with tiewrap plates	Part No. full set without tiewrap plates	A [mm]	B [mm]	Number of teeth
1. ►	117.1.12PZ	117.1.12P	-	25.5	1
2. ►	117.2.12PZ	117.2.12P	12	35.5	3
3. ►	117.3.12PZ	117.3.12P	25	48.5	4
4. ►	117.4.12PZ	117.4.12P	37	60.5	5
5. ►	117.5.12PZ	117.5.12P	48	76	6
6. ►	117.6.12PZ	117.6.12P	65	93	8
7. ►	117.7.12PZ	117.7.12P	85	113	10

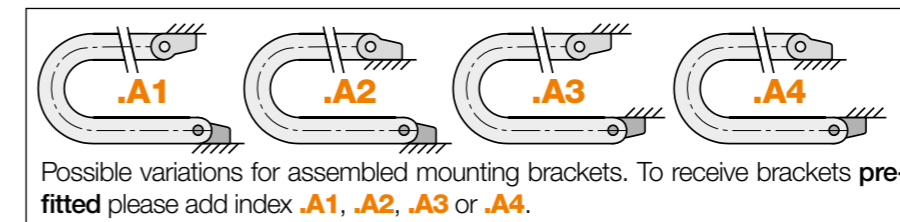

117.2.12PZ.A1 Order example
 .A... to indicate option with brackets pre-fitted
 With integrated strain relief tiewrap plates
 Full set
 Series

Interior separation

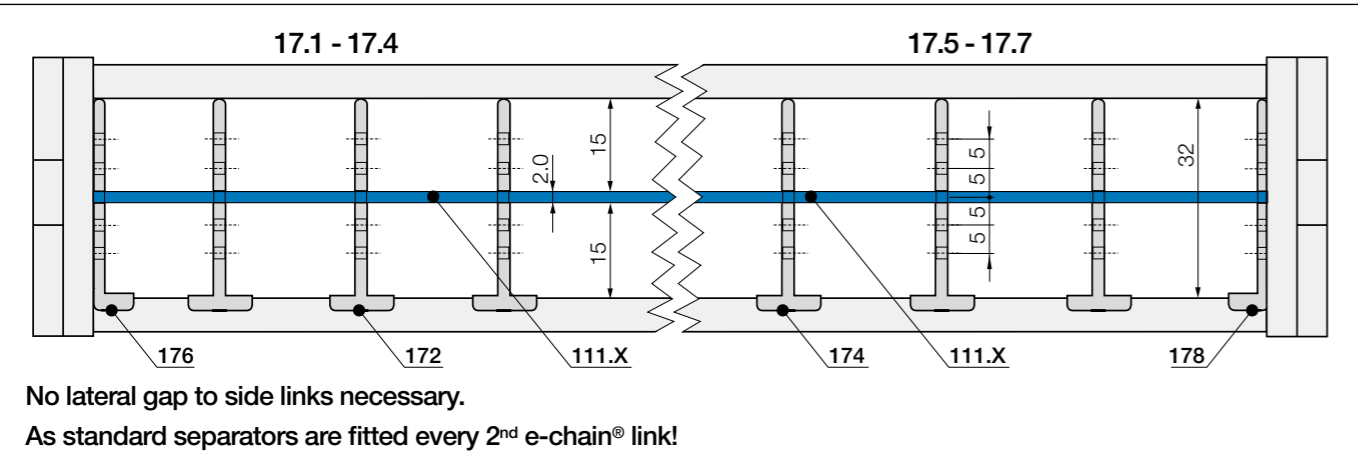

		Slotted separator unassembled 171 assembled 172
--	--	--

For width index 17.1 up to 17.4

Slotted separator

Vertical separation. The slot allows basic vertical/horizontal shelving arrangements.

		Slotted side plate unassembled 175 assembled 176
--	--	---

Slotted side plate

Allows modular shelving right up to the side links. No clearance required!

		Slotted separator unassembled 173 assembled 174
--	--	--

For width index 17.5 up to 17.7

Slotted separator

Vertical separation. The slot allows basic vertical/horizontal shelving arrangements.

		Slotted side plate unassembled 177 assembled 178
--	--	---

Slotted side plate

Allows modular shelving right up to the side links. No clearance required!

		Full-width shelf for e-chains® unassembled 110.X assembled 111.X
--	--	---

For all widths

Full-width shelf

This option is for applications with many small cables with similar diameters. For full-width separation.

Full-width shelves Width = X [mm]	X [mm]	unassembled	assembled	X [mm]	unassembled	assembled	X [mm]	unassembled	assembled
		015	110.15	111.15	050	110.50	111.50	100	110.100
	025	110.25	111.25	063	110.63	111.63			
	038	110.38	111.38	080	110.80	111.80			

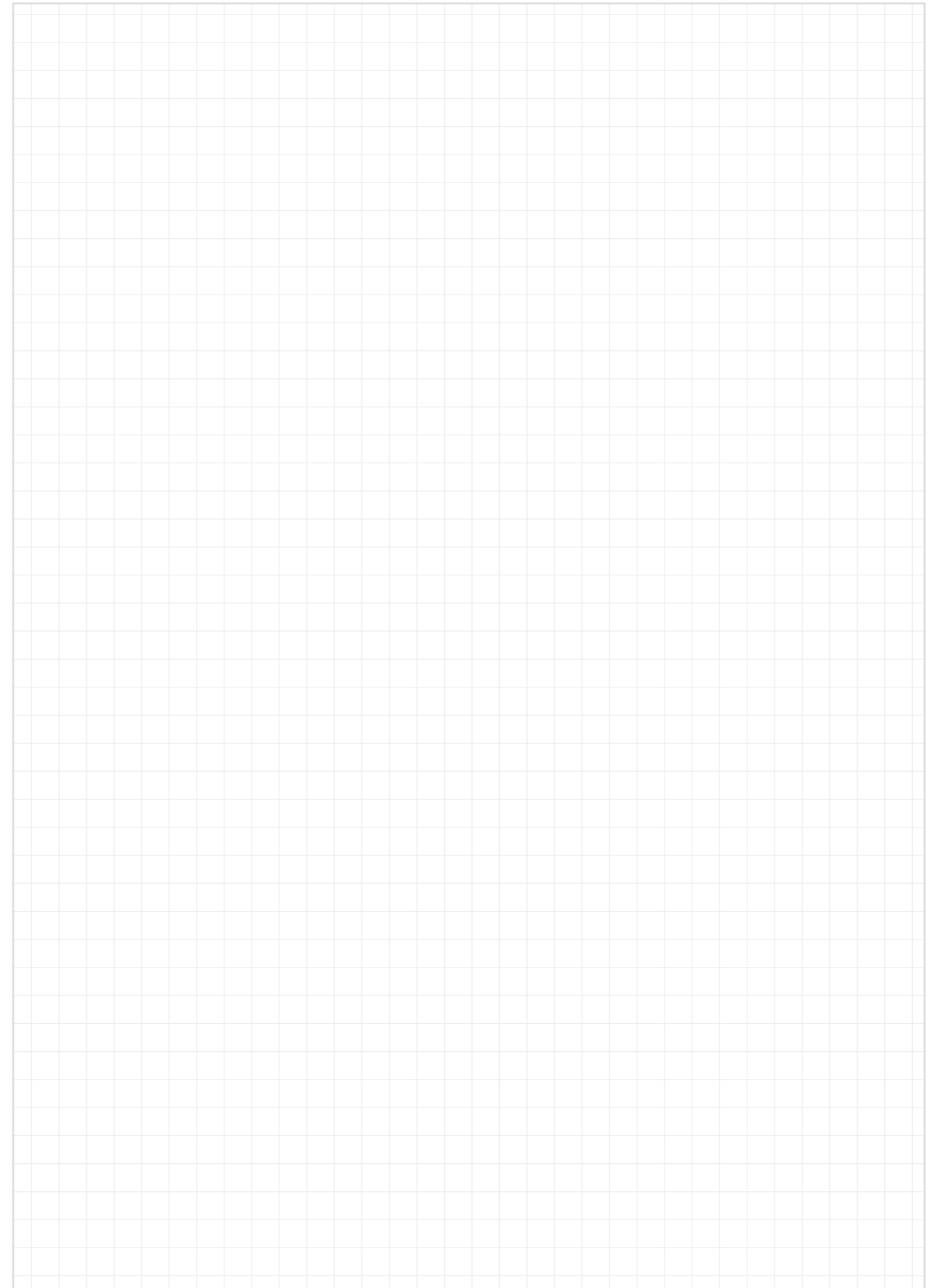

Fast opening, enclosed zipper-band

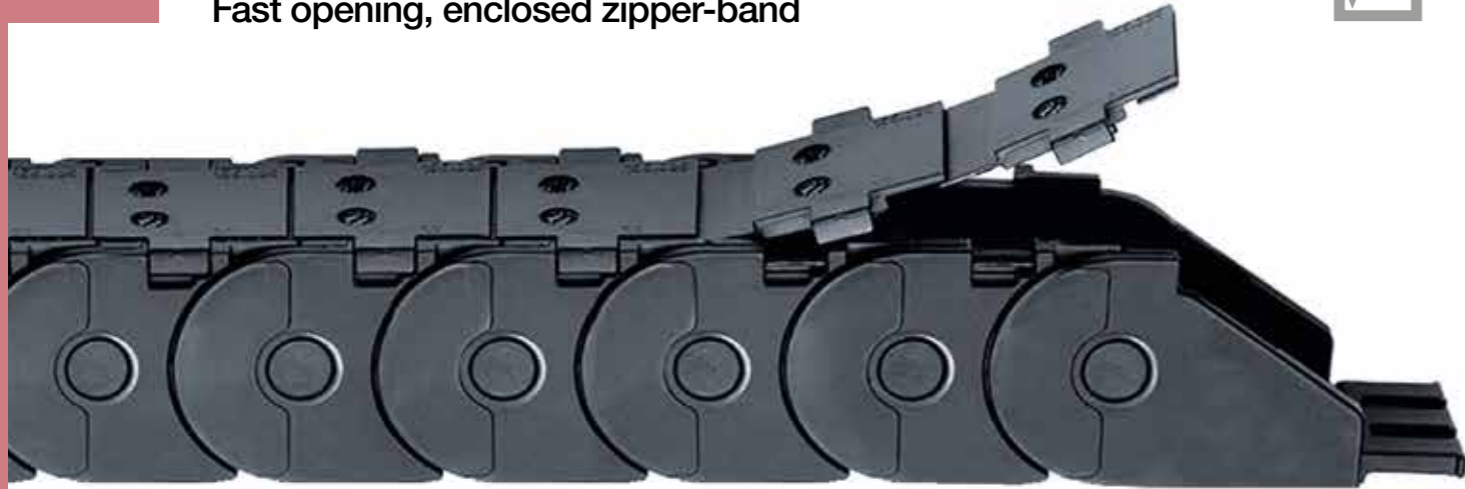
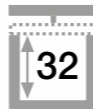

e-tube | Series R17 | Lids on a strip - zip-open along the outer radius

Part No.	Bi	Ba	R Available bend radii				Weight
e-tubes	[mm]	[mm]	[mm]	[mm]	[mm]	[mm]	[kg/m]
R17.015 .R.0	15	26	063	075	100	125	≈ 0.57
R17.025 .R.0	25	36	063	075	100	125	≈ 0.64
R17.063 .R.0	63	74	063	075	100	125	≈ 0.88

Complete Part No. with required radius (R). Example: R17.015.063.0

Installation dimensions

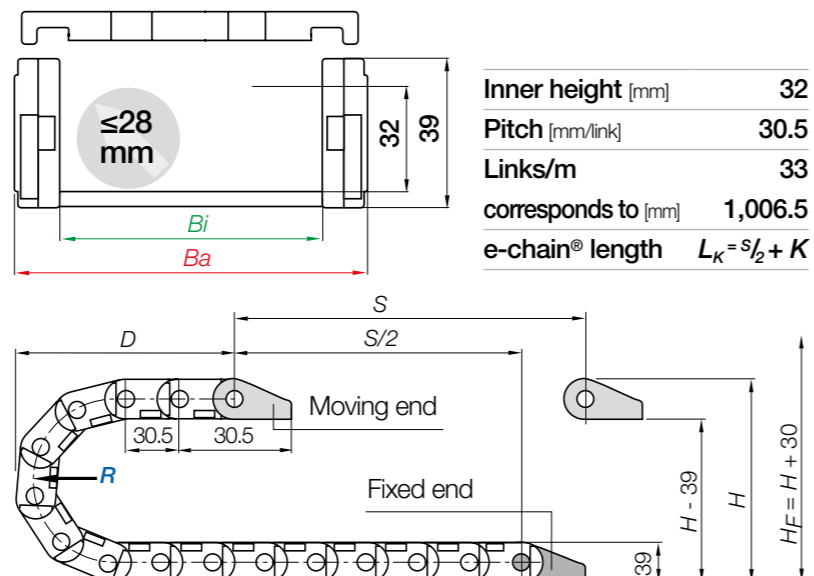
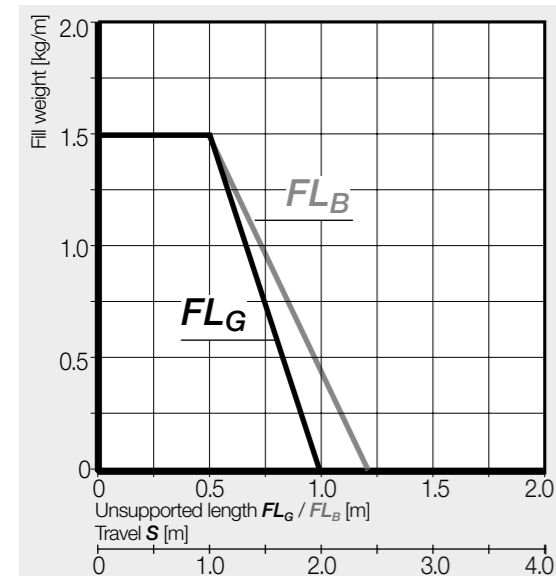

R	063	075	100	125
H	165	189	239	289
D	128	140	165	190
K	260	300	380	455

The required clearance height: $H_F = H + 30\text{mm}$ (with 1.0kg/m fill weight)

Mounting brackets, polymer one-piece | Locking

Moving end
117 ... 1P(Z)

Fixed end
117 ... 2P(Z)

Hole pattern for part numbers 117.015.
= drawing above left
Hole pattern for part numbers 117.025.
= drawing left, centre
Hole pattern for part numbers 117.063.
= drawing below left

Moving end (outer link)
Fixed end (inner link)

Width index	Part No. full set with tiewrap plates	Part No. full set without tiewrap plates	A [mm]	B [mm]	Number of teeth
015. ►	117.015.12PZ	117.015.12P	-	25.7	2
025. ►	117.025.12PZ	117.025.12P	12	35.7	3
063. ►	117.063.12PZ*	117.063.12P*	48	73.7	6

*Pivoting requires rework

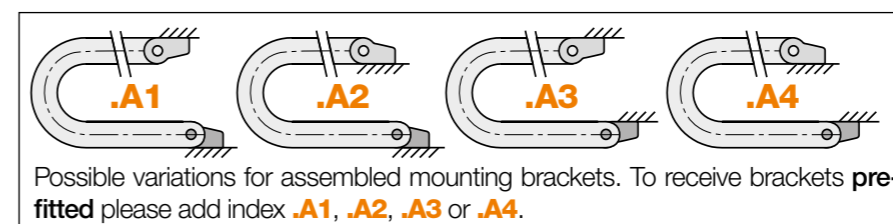

117.015.12PZ.A1 Order example
.A... to indicate option with brackets pre-fitted
With integrated strain relief tiewrap plates
Full set
Series

Interior separation

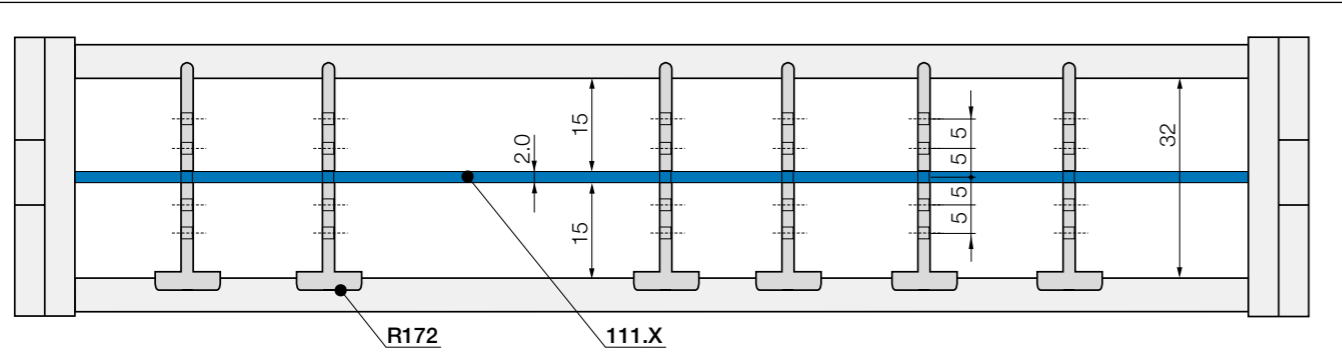

No lateral gap to side links necessary.
As standard separators are fitted every 2nd e-chain® link!

Slotted separator		
unassembled		R171
assembled		R172

Slotted separator
Vertical separation in e-tubes. The slot allows basic vertical/horizontal shelving arrangements.

Full-width shelf for e-tubes		
unassembled		110.X
assembled		111.X

Full-width shelf
This option is for applications with many small cables with similar diameters. For full-width separation.

Full-width shelves Width = X [mm]	X [mm]	unassembled	assembled	X [mm]	unassembled	assembled
		015	110.15	111.15	063	110.63
	025	110.25	111.25			

