 Order key

Type	Size
WA C-06	
Shaft end block	Compact design
	Inner Ø

 Material: aluminium

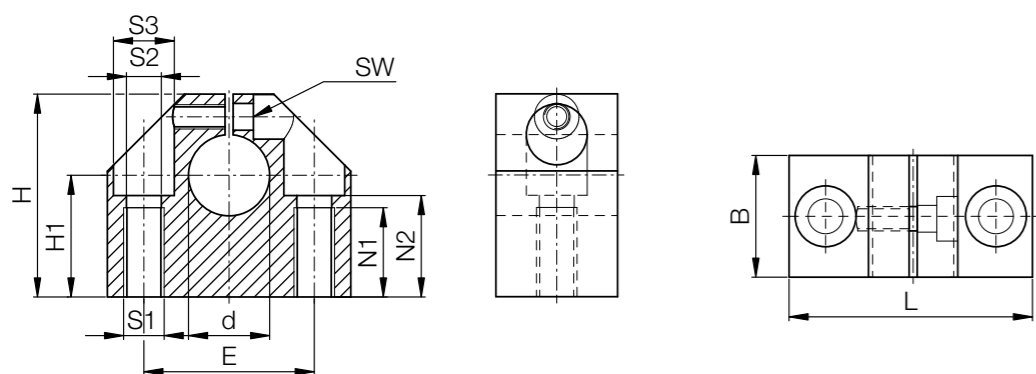

Dimensions [mm]

Part No.	d	B	H	H1 from +0.01 to +0.02	L	S1	S2	S3	E ±0.1	N1	N2	SW	Weight [g]
WAC-06	6	16	27	15	32	M5	4.2	8	22	11	13	2.5	30
WAC-08	8	16	27	16	32	M5	4.2	8	22	11	13	2.5	30
WAC-10	10	18	33	18	40	M6	5.2	10	27	13	16	3.0	50
WAC-12	12	18	33	19	40	M6	5.2	10	27	13	16	3.0	50
WAC-14	14	20	38	20	45	M6	5.2	10	32	13	18	3.0	70
WAC-16	16	20	38	22	45	M6	5.2	10	32	13	18	3.0	70
WAC-20	20	24	45	25	53	M8	6.8	11	39	18	22	4.0	120
WAC-25	25	28	54	31	62	M10	8.6	15	44	22	26	5.0	170
WAC-30	30	30	60	34	67	M10	8.6	15	49	22	29	5.0	220
WAC-40	40	40	76	42	87	M12	10.3	18	66	26	38	6.0	480
WAC-50	50	50	92	50	103	M16	14.25	20	80	34	46	8.0	820

 Order example:  
WAC-12: shaft end block, compact design with inner Ø 12mm

 Order key

Type	Size
WA S-08	
Shaft end block	Narrow design
	Inner Ø

 Material: aluminium

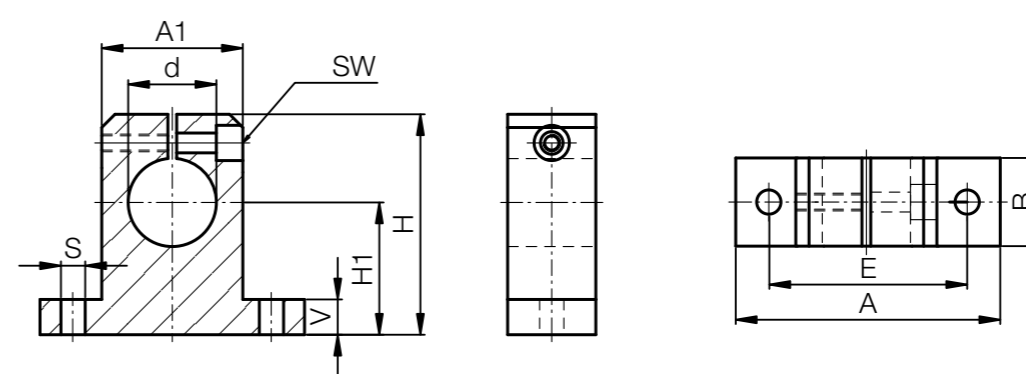

Dimensions [mm]

Part No.	d	H	H1 ±0.02	A	A1	B	E	S	V	SW	Weight [g]
WAS-08	8	27	15	32	16	10	25	4.5	5.0	2.5	12
WAS-12	12	35	20	42	20	12	32	5.5	5.5	3.0	23
WAS-16	16	42	25	50	26	16	40	5.5	6.5	3.0	35
WAS-20	20	50	30	60	32	20	45	5.5	8.0	4.0	67
WAS-25	25	58	35	74	38	25	60	6.6	9.0	4.0	140
WAS-30	30	68	40	84	45	28	68	9.0	10.0	5.0	200
WAS-40	40	86	50	108	56	32	86	11.0	12.0	6.0	480

 Order example:  
WAS-12: shaft end block, narrow design with inner Ø 12mm