

drylin® | Special geometries | Product range

Angular compensation lead screw nut with spherical ball
in flanged bearing housing



Part number Thread

J F R K M-EFOM-TR 8X1.5

iglidur® material	Form F	Hand of rotation	Dimensional series K	Metric	Flanged bearing housing	Trapezoidal thread	Diameter [mm]	Pitch
-------------------	--------	------------------	----------------------	--------	-------------------------	--------------------	---------------	-------

Options:

DS: High helix thread

TR: Trapezoidal thread

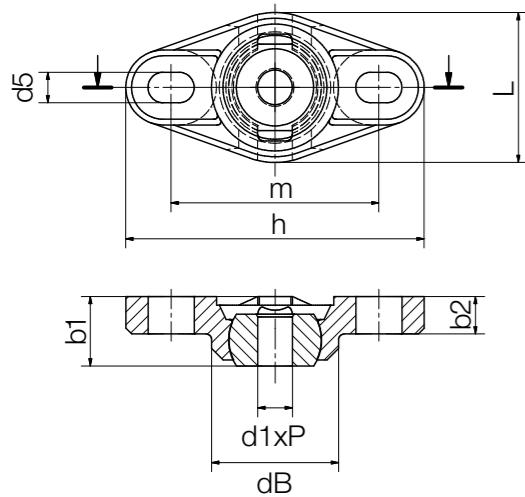

Dimensions [mm] – trapezoidal thread

Thread	Effective support surface [mm²]	d1 ¹⁵⁶⁾	h	L	b1 ¹⁵⁶⁾	b2	m	dB	d5	Max. static axial F [N]	Pivoting angle		Part No.
											stat.	dyn.	
Tr8x1.5	102	8	52	26	12	6.5	36	22.2	5.3x8	100	25°	30°	JFRKM-EFOM-TR8X1.5
Tr10x2	127	10	52	26	12	6.5	36	22.2	5.3x8	100	25°	30°	JFRKM-EFOM-TR10X2
Tr10x3	120	10	52	26	12	6.5	36	22.2	5.3x8	100	25°	30°	JFRKM-EFOM-TR10X3

Dimensions [mm] – high helix thread

Thread	Effective support surface [mm²]	d1 ¹⁵⁶⁾	h	L	b1 ¹⁵⁶⁾	b2	m	dB	d5	Max. static axial F [N]	Pivoting angle		Part No.
											stat.	dyn.	
Ds8x15	61	8	52	26	12	6.5	36	22.2	5.3x8	50	25°	30°	JFRKM-EFOM-DS8X15
Ds10x12	82	10	52	26	12	6.5	36	22.2	5.3x8	50	25°	30°	JFRKM-EFOM-DS10X12

¹⁵⁶⁾ Tolerances according to DIN ISO 2768-1, tolerance class m (medium)

drylin® | Special geometries | Product range

Angular compensation lead screw nut with spherical ball
in pillow block bearing housing



Part number Thread

J F R K M-ESTM-TR 8X1.5

iglidur® material	Form F	Hand of rotation	Dimensional series K	Metric	Pillow block bearing housing	Trapezoidal thread	Diameter [mm]	Pitch
-------------------	--------	------------------	----------------------	--------	------------------------------	--------------------	---------------	-------

Options:

DS: High helix thread

TR: Trapezoidal thread

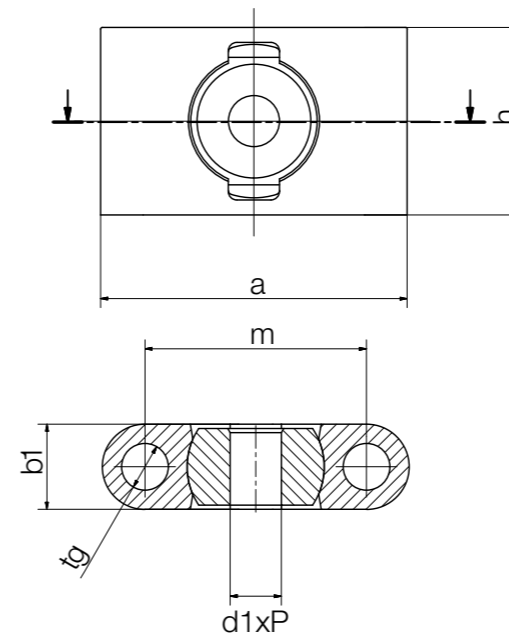

Dimensions [mm] – trapezoidal thread

Thread	Effective support surface [mm²]	h	a	b1 ¹⁵⁶⁾	m	tg	Max. static axial F [N]	Pivoting angle		Part No.
								stat.	dyn.	
Tr8x1.5	102	22	36	10	26	5.5	100	25°	30°	JFRKM-ESTM-TR8X1.5
Tr10x2	127	22	36	10	26	5.5	100	25°	30°	JFRKM-ESTM-TR10X2
Tr10x3	120	22	36	10	26	5.5	100	25°	30°	JFRKM-ESTM-TR10X3

Dimensions [mm] – high helix thread

Thread	Effective support surface [mm²]	h	a	b1 ¹⁵⁶⁾	m	tg	Max. static axial F [N]	Pivoting angle		Part No.
								stat.	dyn.	
Ds8x15	61	22	36	10	26	5.5	50	25°	30°	JFRKM-ESTM-DS8X15
Ds10x12	82	22	36	10	26	5.5	50	25°	30°	JFRKM-ESTM-DS10X12

¹⁵⁶⁾ Tolerances according to DIN ISO 2768-1, tolerance class m (medium)