

drylin® R pillow blocks | Product range

Open, anodised aluminium housing, long design

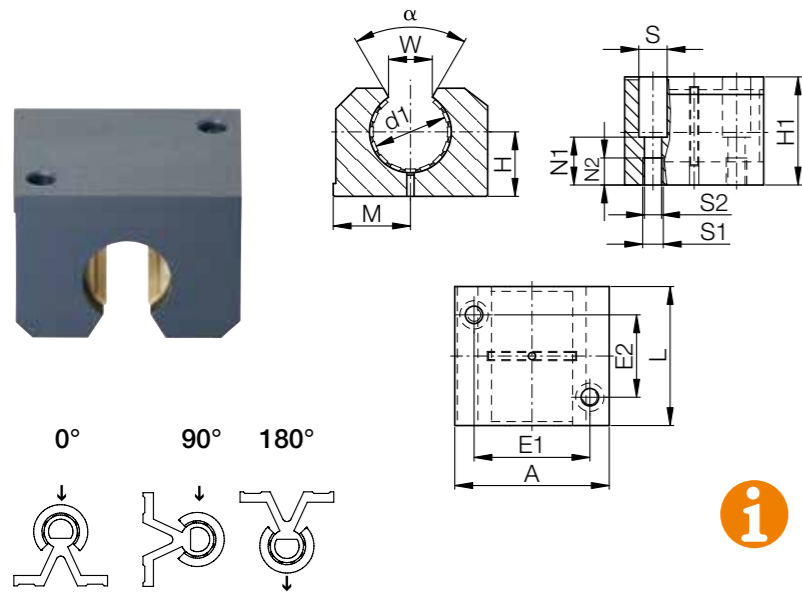

Order key

Type	Size
O J U M-06-12	
Open	
igidur® J	
Liner	
Metric	
Long design	
Inner Ø d1	

i ⁷⁸⁾ According to igus® testing method ▶ Page 1146
⁸²⁾ Design tips ▶ Page 1078
 Please note: Installation instructions ▶ Page 1079

Dimensions [mm]

d1	H	H1	A	M	E1	E2	S	S1	S2	N1	N2	W	α	L	Part No.
	+0.01; -0.014			±0.02	±0.15	±0.15						-1	[°]		
12	18	28	43	21.5	32	23	8.0	M5	4.3	16.5	11	10.2	78	39	OJUM-06-12
16	22	35	53	26.5	40	26	10.0	M6	5.3	21.0	13	11.6	78	43	OJUM-06-16
20	25	42	60	30.0	45	32	11.0	M8	6.6	24.0	18	12.0	60	54	OJUM-06-20
25	30	51	78	39.0	60	40	15.0	M10	8.4	29.0	22	14.5	60	67	OJUM-06-25
30	35	60	87	43.5	68	45	15.0	M10	8.4	34.0	22	16.6	57	79	OJUM-06-30
40	45	77	108	54.0	86	58	18.0	M12	10.5	44.0	26	21.0	56	91	OJUM-06-40
50	50	88	132	66.0	108	50	20.0	M16	13.5	49.0	34	25.5	54	113	OJUM-06-50

Technical data

Part No.	d1 tolerance ⁷⁸⁾	Fmax. dynamic ⁸²⁾ p = 5MPa			Fmax. static ⁸²⁾ p = 35MPa			Weight [g]
		0°	90°	180°	0°	90°	180°	
		OJUM-06-12	+0.030 +0.088	960	635	240	6,720	
OJUM-06-16	+0.030 +0.088	1440	990	396	10,080	6,943	2,772	158
OJUM-06-20	+0.030 +0.091	2250	1,800	900	15,750	12,600	6,300	266
OJUM-06-25	+0.030 +0.091	3625	2,953	1,523	25,375	20,670	10,658	530
OJUM-06-30	+0.040 +0.110	5100	4,250	2,278	35,700	29,735	15,946	818
OJUM-06-40	+0.040 +0.115	8000	6,810	3,800	56,000	47,660	26,600	1,485
OJUM-06-50	+0.050 +0.150	12,500	10,750	6,125	87,500	75,265	42,875	2,750

Available with drylin® liners (optional: J200/A180):



drylin® R pillow blocks | Product range

Open, anodised aluminium housing, long design
with manual clamp

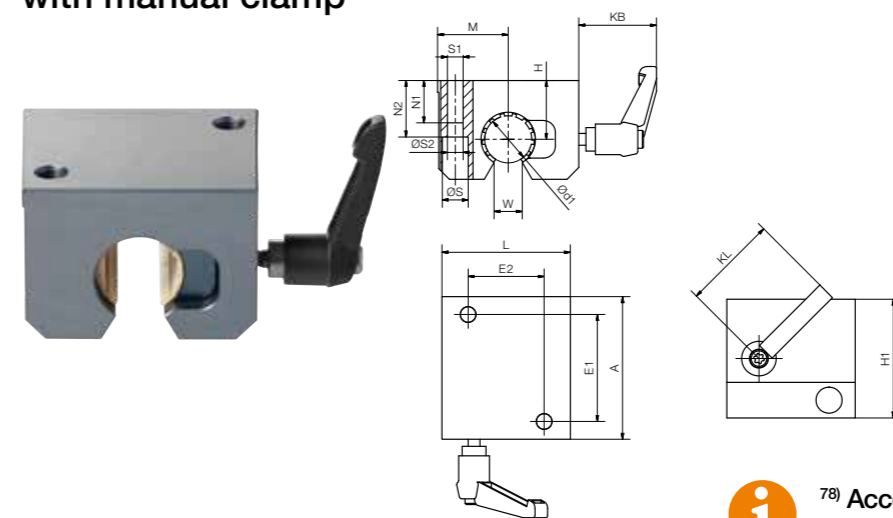

Order key

Type	Size	Options
O J U M-06-12-HK		
Open		
igidur® J		
Liner		
Metric		
Long design		
Inner Ø d1		
Manual clamp		

i ⁷⁸⁾ According to igus® testing method ▶ Page 1146
⁸²⁾ Design tips ▶ Page 1078
 Please note: Installation instructions ▶ Page 1079

Dimensions [mm]

d1	H	H1	A	M	E1	E2	S	S1	S2	N1	N2	W	L	KL	KB	Part No.
	+0.01; -0.014			±0.02	±0.15	±0.15						-1				
12	18	28	43	21.5	32	23	8	M5	4.3	16.5	11	10.2	39	40	33	OJUM-06-12-HK
16	22	35	53	26.5	40	26	10	M6	5.3	21	13	11.6	43	40	33	OJUM-06-16-HK
20	25	42	60	30.0	45	32	11	M8	6.6	24	18	12.0	54	40	33	OJUM-06-20-HK
25	30	51	78	39.0	60	40	15	M10	8.4	29	22	14.5	67	65	46	OJUM-06-25-HK
30	35	60	87	43.5	68	45	15	M10	8.4	34	22	16.6	79	65	46	OJUM-06-30-HK
40	45	77	108	54.0	86	58	18	M12	10.5	44	26	21.0	91	65	46	OJUM-06-40-HK
50	50	88	132	66.0	108	50	20	M16	13.5	49	34	25.5	113	65	46	OJUM-06-50-HK

Technical data

Part No.	d1 tolerance ⁷⁸⁾	Fmax. dynamic ⁸²⁾ p = 5MPa			Fmax. static ⁸²⁾ p = 35MPa			Clamp force axial [N]	Weight [g]
		0°	90°	180°	0°	90°	180°		
		OJUM-06-12-HK	+0.030 +0.088	960	635	240	6720		
OJUM-06-16-HK	+0.030 +0.088	1440	990	396	10080	6943	2772	400	0.164
OJUM-06-20-HK	+0.030 +0.091	2250	1800	900	15750	12600	6300	400	0.275
OJUM-06-25-HK	+0.030 +0.091	3625	2953	1523	25375	20670	10658	1,000	0.544
OJUM-06-30-HK	+0.040 +0.110	5100	4250	2278	35700	29735	15946	1,000	0.832
OJUM-06-40-HK	+0.040 +0.115	8000	6810	3800	56000	47660	26600	1,000	1.513
OJUM-06-50-HK	+0.050 +0.150	12500	10750	6125	87500	75265	42875	1,000	2.568

Available with drylin® liners (optional: J200/A180):

