

Lead screw nuts with flange (form F)

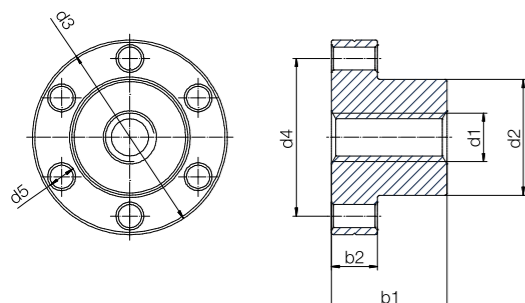
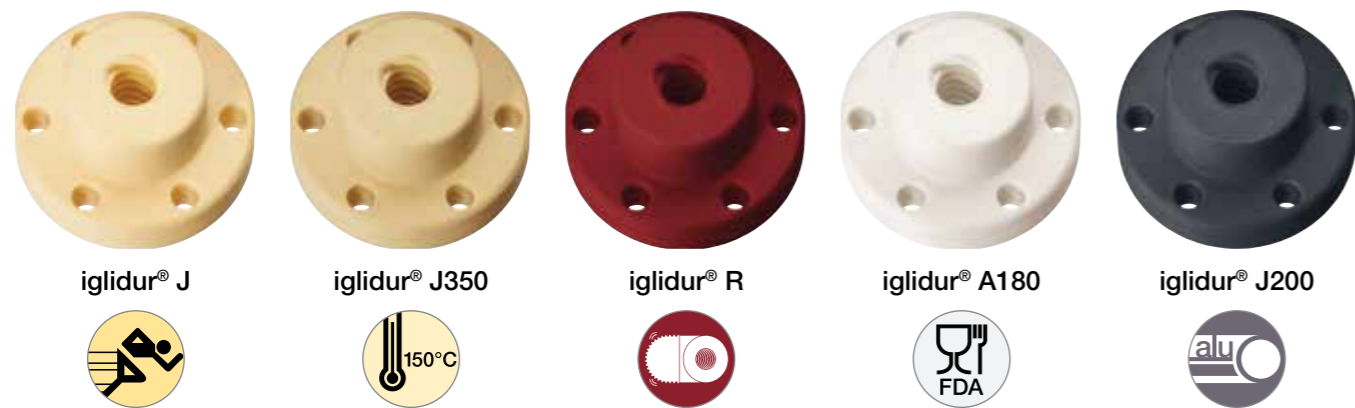

Technical data

Thread	Hand of rotation		Effective supporting surface [mm²]	Max. stat. axial F [N]		
	right	left		igidur®		
			J / J350 / A180	R	J200	
Ds4x2.4	●	–	69	125	125	–
Ds5x5	●	–	66	152	152	–
Ds6.35x2.54	●	●	199	125	125	–
Ds6.35x5.08	●	–	156	125	125	–
Ds6.35x12.7	●	–	78	125	125	–
Ds6.35x25.4	●	–	86	125	125	–
Ds8x10	●	●	203	508	406	–
Ds8x15	●	●	205	635	507	–
Ds8x24	●	–	173	432.5	346	–
Ds10x3	●	●	512	1,280	1,024	–
Ds10x12	●	●	343	845	677	–
Ds10x25	●	●	312	780	623	–
Ds10x50	●	●	181	453	361	–
Ds12x5	●	–	581	1,425	1,140	–
Ds12.7x12.7	●	–	599	1,497.5	1,198	–
Ds12x15	●	–	923	1,443	1,155	–
Ds12x25	●	–	562	1,405	1,124	–
Ds14x25	●	●	576	1,428	1,142	–
Ds14x30	●	–	571	1,428	1,142	–
Ds14x40.6	●	–	434	1,085	868	–
Ds16x35	●	–	668	1,670	1,335	1,336

Order key

Type d2 b1 Thread

**DST-□ F R M-25 25DS 10X12**

dryspin® technology	igidur® material	Form F	Hand of rotation	Metric	Outer Ø [mm]	Length [mm]	Thread type	Diameter [mm]	Pitch
	J								
	J350								
	R								
	A180								
	J200								

Options:  
Hand of rotation  
R: Right-hand thread  
L: Left-hand thread

- J** High efficiency at all speeds
- J350** For temperatures up to +150°C
- R** The cost-effective option for high volume
- A180** FDA-compliant for the food and pharmaceutical industries
- J200** The specialist on hard anodised aluminium

Dimensions [mm]

d1 <sup>156)</sup>	d2 <sup>156)</sup>	d3	d4	d5	b1 <sup>156)</sup>	b2	Weight [g]					Part No.
							igidur®					
							J	J350	R	A180	J200	
4.0	13	25	15	3.2	15	5	7.6	7.35	7.09	7.45	–	DST-□FRM-1315DS4X2.4
5.0	13	25	19	3.2	15	5	4.9	4.8	4.6	4.8	–	DST-□FRM-1315DS5X5 <span style="color: orange;">New</span>
6.35	13	25	19	3.2	15	5	4.9	4.8	4.6	4.8	–	DST-□F□M-1315DS6.35X2.54
6.35	13	25	19	3.2	15	5	4.9	4.8	4.6	4.8	–	DST-□FRM-1315DS6.35X5.08
6.35	13	25	19	3.2	15	5	4.9	4.8	4.6	4.8	–	DST-□FRM-1315DS6.35X12.7
6.35	13	25	19	3.2	15	5	4.9	4.8	4.6	4.8	–	DST-□FRM-1315DS6.35X25.4
8	20	36	28	4	20	8	12.3	11.9	11.5	12.0	–	DST-□F□M-2020DS8X10
8	20	36	28	4	20	8	12.3	11.9	11.5	12.0	–	DST-□F□M-2020DS8X15
8	20	36	28	4	20	8	12.3	11.9	11.5	12.0	–	DST-□FRM-2020DS8X24 <span style="color: orange;">New</span>
10	25	42	34	5	25	10	28.7	27.7	26.8	28.1	–	DST-□FRM-2525DS10X3 <span style="color: orange;">New</span>
10	25	42	34	5	25	10	28.7	27.7	26.8	28.1	–	DST-□F□M-2525DS10X12
10	25	42	34	5	25	10	28.7	27.7	26.8	28.1	–	DST-□F□M-2525DS10X25
10	25	42	34	5	25	10	28.7	27.7	26.8	28.1	–	DST-□F□M-2525DS10X50
12	28	48	38	6	35	12	47.6	46.0	44.4	46.6	–	DST-□FRM-2835DS12X5
12	28	48	38	6	35	18	47.6	46.0	44.4	46.6	–	DST-□FRM-2835DS12.7X12.7 <span style="color: orange;">New</span>
12	28	48	38	6	35	18	47.6	46.0	44.4	46.6	–	DST-□FRM-2835DS12X15 <span style="color: orange;">New</span>
12	28	48	38	6	35	18	47.6	46.0	44.4	46.6	–	DST-□FRM-2835DS12X25
14	28	48	38	6	35	12	45.4	43.9	42.4	44.5	–	DST-□F□M-2835DS14X25
12	28	48	38	6	35	18	45.4	43.9	42.4	44.5	–	DST-□FRM-2835DS14X30
14	28	48	38	6	35	12	45.4	43.9	42.4	44.5	–	DST-□FRM-2835DS14X40.6
16	28	48	38	6	35	12	43.0	41.5	40.1	42.1	50	DST-□FRM-2835DS16X35

<sup>156)</sup> Tolerances according to DIN ISO 2768-1, tolerance class m (medium)

## Technical data

Thread	Hand of rotation		Effective supporting surface [mm²]	Max. stat. axial F [N]		
	right	left		iglidur®		
				J / J350 / A180	R	J200
Ds18x24	●	●	844	2,110	1,688	1,688
Ds18x40	●	●	764	1,910	1,529	1,528
Ds18x80	●	●	528	1,320	1,056	1,056
Ds18x100	●	●	463	1,158	926	926
Ds20x20	●	●	1,083	2,708	2,165	2166
Ds20x50	●	–	729	1,823	1,458	1,750
Ds20x60	●	●	729	1,823	1,458	1,458
Ds20x80	●	●	755	1,888	1,510	1,510
Ds20x90	●	●	671	1,678	1,342	1,342

## Dimensions [mm]

d1 <sup>156)</sup>	d2 <sup>156)</sup>	d3	d4	d5	b1 <sup>156)</sup>	b2	Weight [g]					Part No.
							iglidur®					
							J	J350	R	A180	J200	
18	28	48	38	6	35	12	50.9	49.2	47.4	49.8	48	DST-□F□M-2835DS18X24
18	28	48	38	6	35	12	50.9	49.2	47.4	49.8	48	DST-□F□M-2835DS18X40
18	28	48	38	6	35	12	50.9	49.2	47.4	49.8	48	DST-□F□M-2835DS18X80
18	28	48	38	6	35	12	50.9	49.2	47.4	49.8	48	DST-□F□M-2835DS18X100
20	32	55	45	7	44	12	60.2	58.2	56.2	59.0	73	DST-□F□M-3244DS20X20
20	32	55	45	7	44	12	60.2	58.2	56.2	59.0	73	DST-□F□M-3244DS20X50
20	32	55	45	7	44	12	60.2	58.2	56.2	59.0	73	DST-□F□M-3244DS20X60
20	32	55	45	7	44	12	60.2	58.2	56.2	59.0	73	DST-□F□M-3244DS20X80
20	32	55	45	7	44	12	60.2	58.2	56.2	59.0	73	DST-□F□M-3244DS20X90

<sup>156)</sup> Tolerances according to DIN ISO 2768-1, tolerance class m (medium)