



TW-03



Complete system online



Order key

Type

TW-03-25

- Guide carriage
- Reduced weight
- Installation size

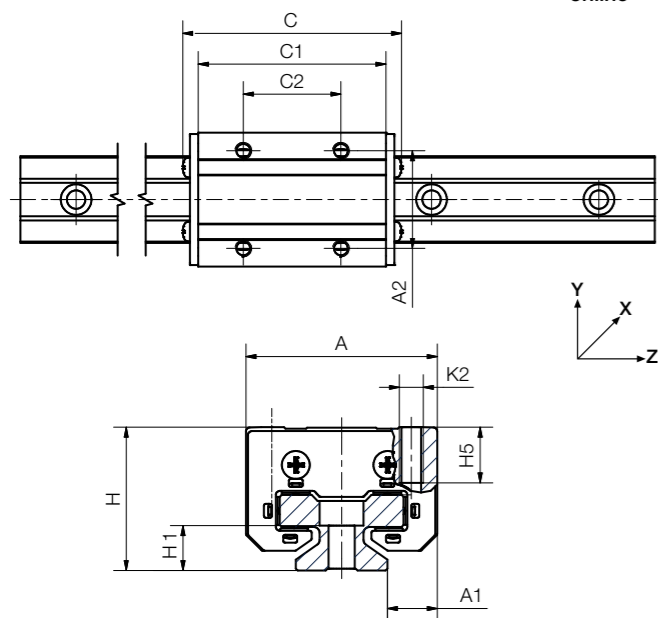

Dimensions [mm]

Part No.	Weight [kg]	H ±0.35	A	C	A1	A2	C1 ±0.35	C2 ±0.35	H1	H5	K2	Tightening torque Max. [Nm]
TW-03-25	0.16	36	48	81	14	35	67.4	35	5	13	M6	6.0



All elements can be ordered individually or as assembled systems

TW-03-25: Compact guide carriage, installation size 25

TK-03-25-2-500: Complete system with two compact guide carriages type 03, installation size 25 and standard guide rail, 500mm length

Can only be combined with:



TS-01-20



TS-11-20



Technical data

► Page 1059

Compact design

Plastic clamping elements



TWBM-11

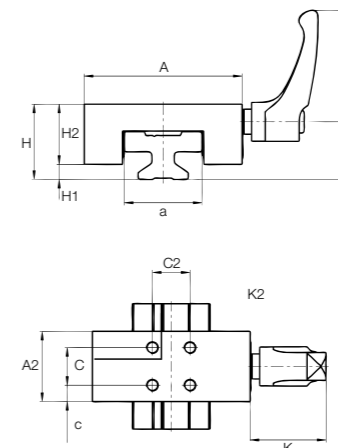

Dimensions [mm]

Part No.	Clamp force [N]	A	a	A2	H	H1	H2	K	K2	C	C2	c	lg	b
TWBM-11-15	180	47	22	23	24	4	20	30	M4	15	15	4	44	18.9
TWBM-11-20	180	63	31	28	30	5	24	30	M5	15	15	6.5	44	23.0
TWBM-11-25	400	70	34	35	36	5	31	39	M6	20	20	7.5	63.63	26.2
TWBM-11-30	500	90	40	38	42	6.5	35.5	47	M6	20	20	9	78	32.4



Order key

Type

TWBM-11-15

- Manual clamp
- Compact
- Installation size

Standard design

with brass clamp



TWBM-01

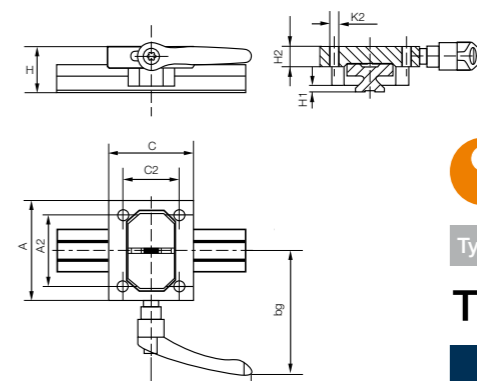

Dimensions [mm]

Part No.	Clamp force [N]	A	A2	H	H1	H2	K2	C	C2	lg	bg
TWBM-01-25	500	80	57	36	5	16	M8	68	45	80	99



Order key

Type

TWBM-01-25

- Manual clamp
- Standard
- Installation size

Can only be combined with:



TS-01-...