

Order key

Type	Size	Option
------	------	--------

AWM Q - 10 - 1000

Aluminium shaft	Metric	Square design	Installation size	Length [mm]
-----------------	--------	---------------	-------------------	-------------

Minimum saw lengths
▶ Page 961

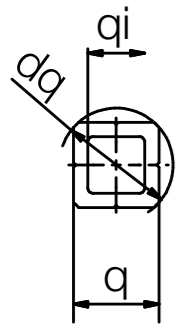

Dimensions [mm]

Part No.	Weight [kg/m]	q	dq	qi ±0.02	Max. length
AWMQ-10	0.082	7.5	10	5	1,500
AWMQ-12	0.193	12	16	8.5	1,500
AWMQ-20	0.46	20	25	15	3,000

Accessories

Shaft end supports made from plastic



- Cost-effective mounting option
- Can also be used as floating bearing

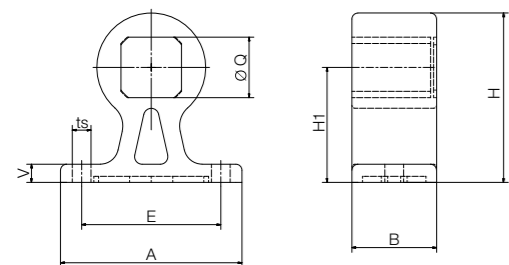

Dimensions [mm]

Part No.	A	H	B	Q	H1	E	ts	V
STZ-Q10-01-FL	30	21	14	7.5	14	20	3.3	3
STZ-Q20-01-FL	60	56	28	20	38	46	6.2	6

End caps for square section linear rail

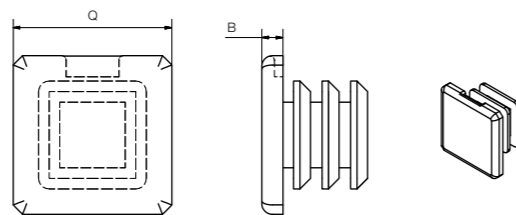

Dimensions [mm]

Part No.	Q	B
STZ-Q10-01-C	7.5	1
STZ-Q20-01-C	20	5

Order key

Type	Size
------	------

QWE - 01 - 20

Square	Linear carriage	Adjustable	Standard design	Installation size
--------	-----------------	------------	-----------------	-------------------

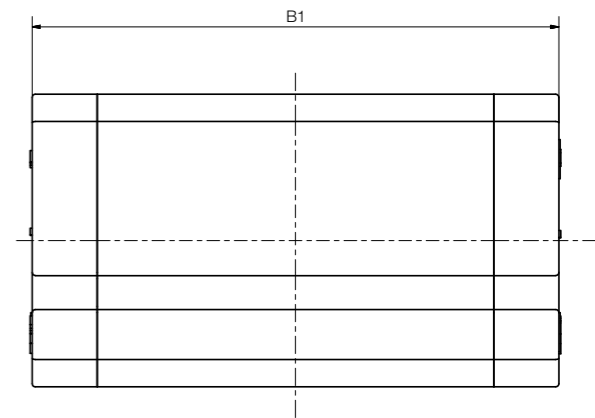
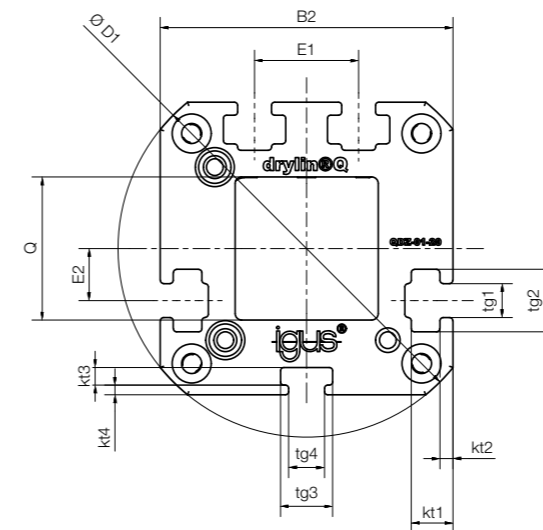

Dimensions [mm]

Part No.	Weight [g]	M max. [Nm]	B1	B2 h7	D1	Q	E1	E2	tg1	tg2	tg3	tg4	kt1	kt2	kt3	kt4
QWE-01-12	110	5	80	34	44	12	12	6	5.5	8	8	-	-	-	3	1.25
QWE-01-20	210	10	81	45	58	20	16	8	5.5	9.6	8	5.5	6.4	2	2.7	1.5

Accessories: Slot nuts



Slot nuts offers attachment options (for example sensors) on four sides of the housing. 8 pieces are included in the delivery of a QWE carriage.
Part No.: **NOR-20602**

Can be combined with:

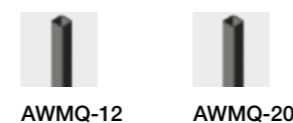

AWMQ-12

AWMQ-20