

iglidur® J | The Fast and Slow Motion Specialist

Used in long-life applications, also with soft shafts. The iglidur® J plain bearings are designed for the lowest coefficients of friction while running dry and low stick slip tendency. With a maximum permissible surface pressure of 35 MPa iglidur® J plain bearings are not suitable for extreme loads.

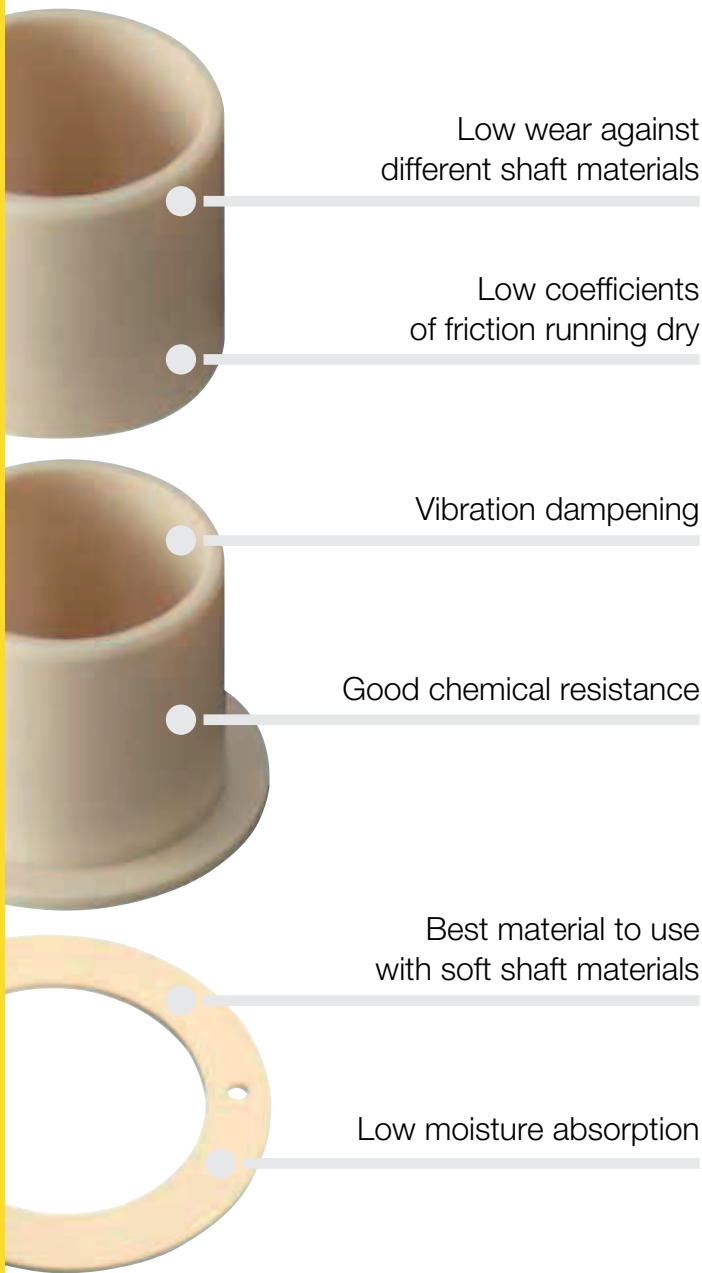

When to use it?

- For high speeds
- For highest wear resistance at low to medium pressures
- Low wear against different shafts
- Low coefficient of friction in dry run
- Vibration dampening
- Good chemical resistance
- Best performance with soft shaft materials
- Low moisture absorption



When not to use it?

- When high pressures occur
 - ▶ iglidur® G, page 61
 - ▶ iglidur® W300, page 131
- When short term temperatures occur that are greater +120 °C
 - ▶ iglidur® G, page 61
 - ▶ iglidur® Z, page 299
- When a low-cost bearing for occasional movements is necessary
 - ▶ iglidur® G, page 61

Temperature

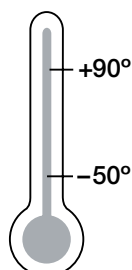

Product range

3 types
> 250 dimensions
Ø 2–100 mm



iglidur® J | Application Examples



Typical sectors of industry and application areas

- Automation ● Printing industry
- Beverage technology ● Aerospace engineering ● Cleanroom etc.

Improve technology and reduce costs – 310 exciting examples for iglidur® plain bearings online

► www.igus.eu/eu/iglidur-applications



► www.igus.eu/mountainbike



► www.igus.eu/powderpress



► www.igus.eu/pullback-star



► www.igus.eu/sawmill

Material table

General properties	Unit	iglidur® J	Testing method
Density	g/cm ³	1.49	
Colour		yellow	
Max. moisture absorption at +23 °C/50 % r.h.	% weight	0.3	DIN 53495
Max. moisture absorption	% weight	1.3	
Coefficient of sliding friction, dynamic against steel	μ	0.06–0.18	
pv value, max. (dry)	MPa · m/s	0.34	
Mechanical properties			
Modulus of elasticity	MPa	2,400	DIN 53457
Tensile strength at +20 °C	MPa	73	DIN 53452
Compressive strength	MPa	60	
Max. static surface pressure (+20 °C)	MPa	35	
Shore D hardness		74	DIN 53505
Physical and thermal properties			
Max. long term application temperature	°C	+90	
Max. short term application temperature	°C	+120	
Min. application temperature	°C	-50	
Thermal conductivity	W/m · K	0,25	ASTM C 177
Coefficient of thermal expansion (at +23 °C)	K ⁻¹ · 10 ⁻⁵	10	DIN 53752
Electrical properties			
Specific volume resistance	Ωcm	> 10 ¹³	DIN IEC 93
Surface resistance	Ω	> 10 ¹²	DIN 53482

Table 01: Material data

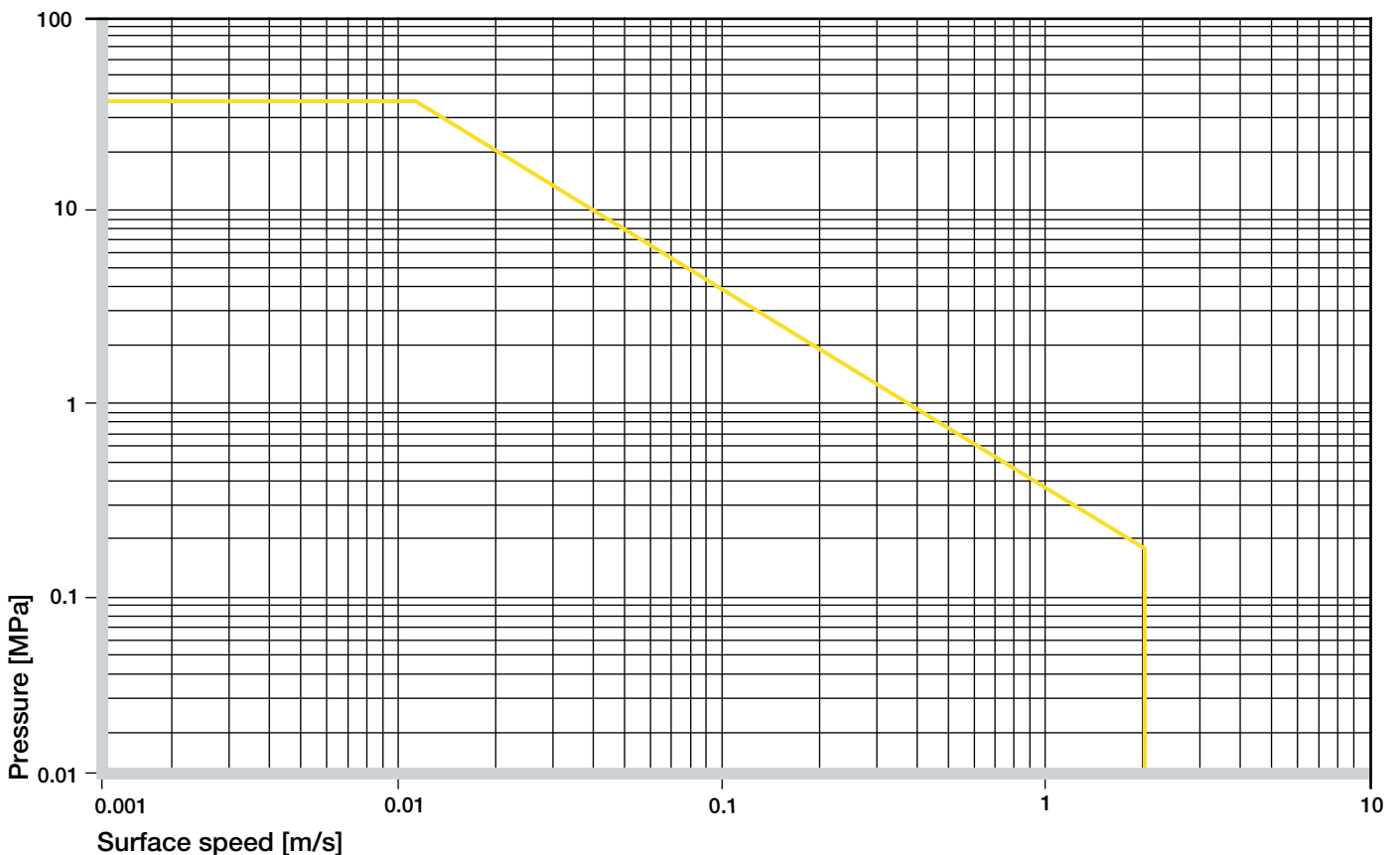

Graph 01: Permissible pv values for iglidur® J with a wall thickness of 1 mm dry running against a steel shaft at +20 °C, mounted in a steel housing

iglidur® J | Technical Data

Mechanical Properties

The recommended maximum surface pressure is a mechanical material parameter. No conclusions regarding the tribological properties can be drawn from this. With increasing temperatures, the compressive strength of iglidur® J plain bearings decreases. The Graph 02 shows this inverse relationship. However, at the longterm maximum temperature of +90 °C the permissible surface pressure is almost 20 MPa.

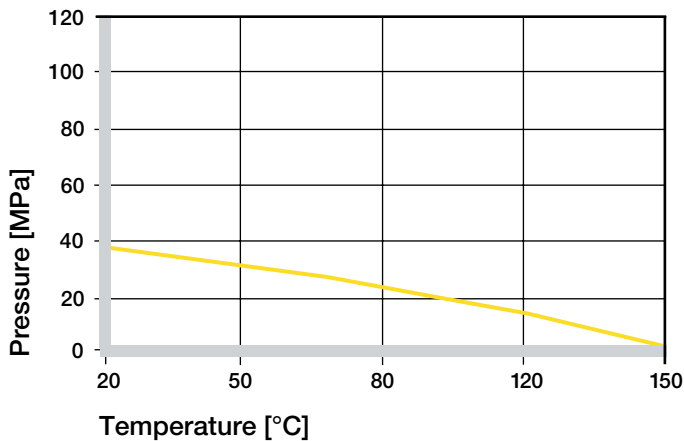

Graph 02: Recommended maximum surface pressure as a function of temperature (35 MPa at +20 °C)

One main advantage of iglidur® J plain bearings is the combination of a low coefficient of friction when running dry, the low stick-slip tendency, and the excellent wear rate at low pressure. With a recommended maximum surface pressure of 35 MPa, iglidur® J plain bearings are not suitable for extreme loads. Graph 03 shows the elastic deformation of iglidur® J for radial loads. At the recommended maximum surface pressure of 35 MPa the deformation is less than 2.5 %.

► Surface Pressure, page 43

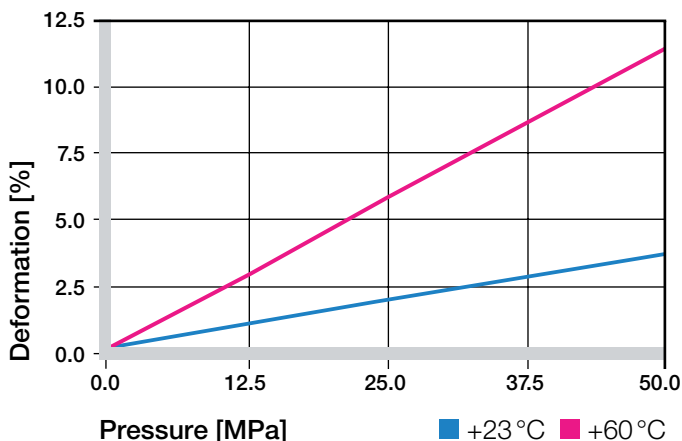

Graph 03: Deformation under pressure and temperature

Permissible Surface Speeds

The low coefficient of friction and the extremely low stick-slip tendency of iglidur® J plain bearings are especially important at very low speeds. However, iglidur® J material can also be used for high speeds of over 1 m/s. In both cases the static friction is very low and stick-slip does not occur.

The maximum values given in Table 02 can only be achieved at the lowest pressure loads. At the given speeds, friction can cause a temperature increase to maximum permissible levels. In practice, though, this temperature level is rarely reached, due to varying application conditions.

► Surface Speed, page 45

m/s	Rotating	Oscillating	Linear
Continuous	1.5	1.1	8
Short term	3	1.1	10

Table 02: Maximum surface speeds

Temperatures

iglidur® J plain bearings can be used between -50 °C and +90 °C; the short-term maximum permissible temperature is +120 °C. Also, the wear increases significantly above +80 °C.

► Application Temperatures, page 46

iglidur® J	Application temperature
Minimum	-50 °C
Max., long term	+90 °C
Max., short term	+120 °C
Add. securing is required from	+60 °C

Table 03: Temperature limits

Friction and Wear

Similar to wear resistance, the coefficient of friction μ also changes with the load. Graph 05 shows the coefficients of friction for different loads. The level of the coefficient of friction is very good for all loads with iglidur® J.

► Coefficients of Friction and Surfaces, **page 48**

► Wear Resistance, **page 49**

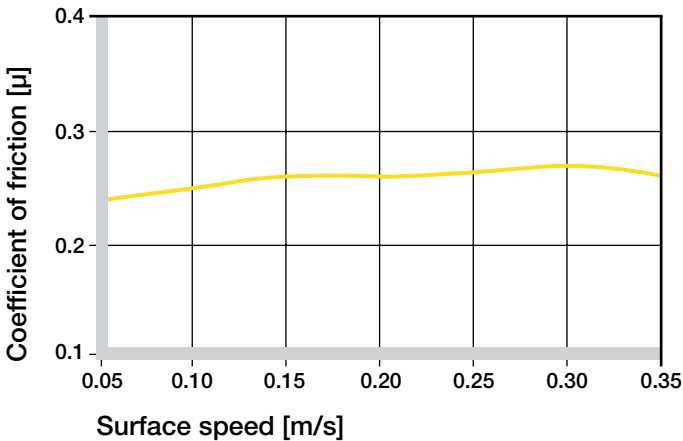

Graph 04: Coefficient of friction as a function of the running speed, $p = 0.75 \text{ MPa}$

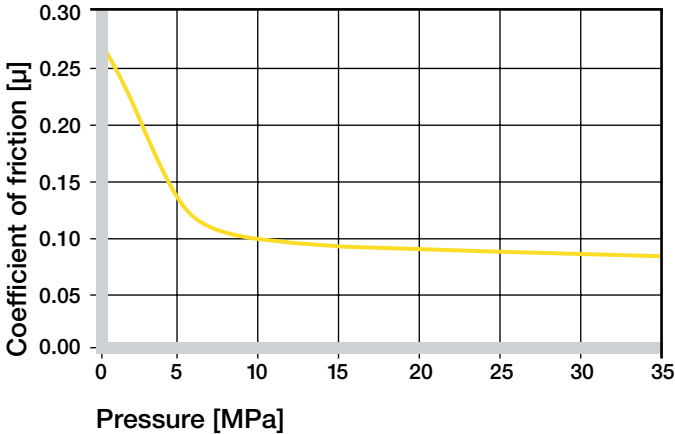

Graph 05: Coefficient of friction as a function of the pressure, $v = 0.01 \text{ m/s}$

Shaft Materials

Friction and wear are also dependent, to a large extent, on the shaft material. With increasing shaft roughness, the coefficient of friction also increases. The best case is a ground surface with an average roughness $R_a = 0.1\text{--}0.3 \mu\text{m}$ (Graph 06).

Graphs 07 to 09 show results of testing different shaft materials with plain bearings made of iglidur® J.

If iglidur® J plain bearings are used in rotational applications with pressures under 2 MPa, several shaft materials are suitable. A Hard Chromed shaft provides the lowest wear in this range. When compared to most iglidur® materials, iglidur® J has very low wear results at low loads compared with all shaft materials tested. Also, for increasing pressures up to 5 MPa, the wear resistance of iglidur® J is excellent. Especially suitable is the combination with 303 stainless steel.

In oscillating operation with Cf53 Steel and HR Carbon Steel, the wear of iglidur® J is slightly higher than for rotation. For oscillating movements with loads of 2 MPa, iglidur® J is best combined with Cf53 Steel shaft. As Graph 09 shows, the difference in wear between rotation and oscillating movements is most significant for 303 stainless steel shafts. If the shaft material you plan to use is not contained in this list, please contact us.

► Shaft Materials, **page 51**

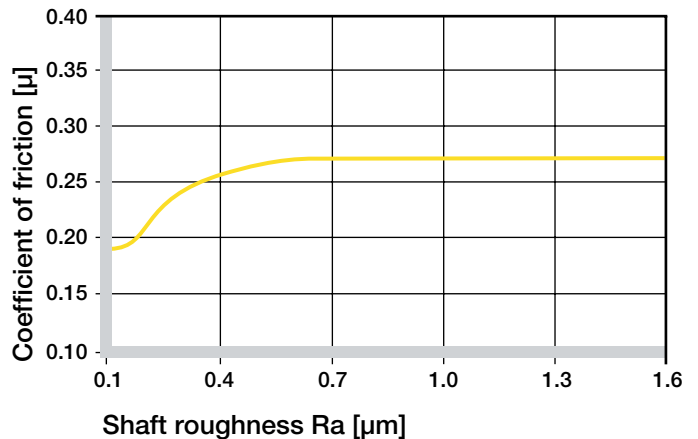

Graph 06: Coefficient of friction as function of the shaft surface (Cf53 hardened and ground steel)

iglidur® J | Technical Data

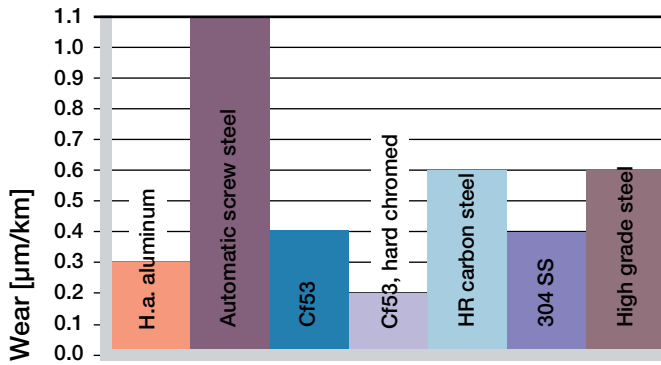

Graph 07: Wear, rotating with different shaft materials, pressure $p = 0.75 \text{ MPa}$, $v = 0.5 \text{ m/s}$

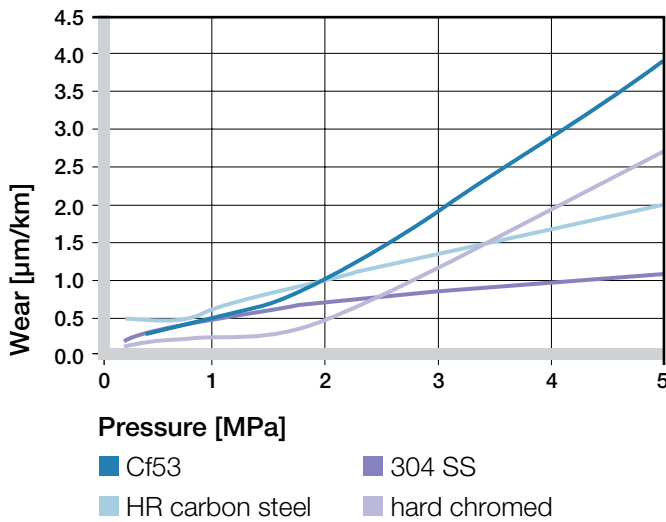

Graph 08: Wear with different shaft materials in rotational operation, as a function of the pressure

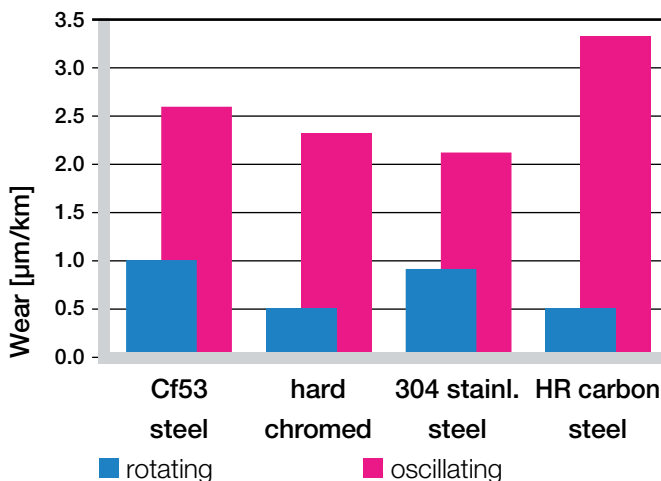

Graph 09: Wear for rotating and oscillating applications with different shaft materials, $p = 2 \text{ MPa}$

iglidur® J	Dry	Grease	Oil	Water
C.o.f. μ	0.06–0.18	0.09	0.04	0.04

Table 04: Coefficients of friction against steel ($R_a = 1 \text{ }\mu\text{m}$, 50 HRC)

Additional Properties

Chemical Resistance

iglidur® J plain bearings are resistant to diluted alkaline and very weak acids, as well as fuels and all types of lubricants. The low moisture absorption also permits use in wet or damp environments.

Plain bearings made of iglidur® J are resistant to common cleaning agents used in the food industry.

► Chemical Table, page 974

Medium	Resistance
Alcohol	+
Hydrocarbons	+
Greases, oils without additives	+
Fuels	+
Diluted acids	0 to –
Strong acids	–
Diluted alkalines	+
Strong alkalines	+ to 0

+ resistant 0 conditionally resistant – not resistant

All data given at room temperature [$+20 \text{ }^\circ\text{C}$]

Table 05: Chemical resistance

Radiation Resistance

Plain bearings made from iglidur® J are resistant to radiation up to an intensity of $3 \cdot 10^2 \text{ Gy}$.

UV Resistance

iglidur® J plain bearings become discoloured under UV radiation. However, hardness, compressive strength and the wear resistance of the material do not change.

Vacuum

When used in a vacuum environment, the iglidur® J plain bearings release moisture as a vapour. Therefore, only dehumidified bearings are suitable in a vacuum environment.

Electrical Properties

iglidur® J plain bearings are electrically insulating.

Specific volume resistance > 10¹³ Ωcm

Surface resistance > 10¹² Ω 10

Moisture Absorption

The moisture absorption of iglidur® J plain bearings is 0.3% in standard atmosphere. The saturation limit in water is 1.3%. These values are so low that design changes due to absorption are only necessary in extreme cases.

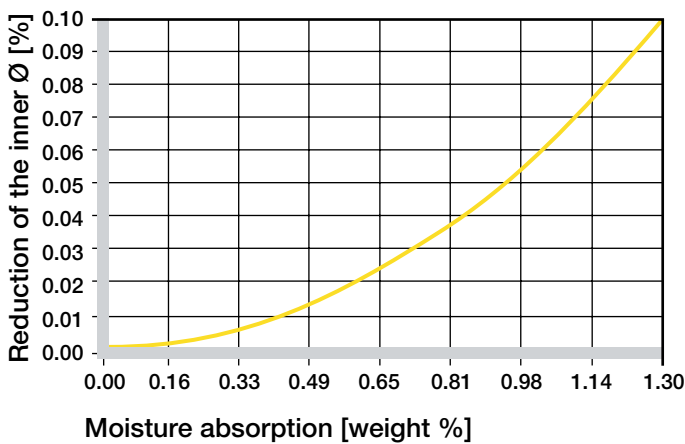

Graph 10: Effect of moisture absorption on plain bearings

Maximum moisture absorption

At +23 °C/50 % r.h. 0.3 % weight

Max. moisture absorption 1.3 % weight

Table 06: Moisture absorption

Installation Tolerances

iglidur® J plain bearings are meant to be oversized before pressfit. The bearings are designed for pressfit into a housing machined to a H7 tolerance. After being assembled into a nominal size housing, the inner diameter adjusts to meet our specified tolerances.

► Testing Methods, page 55

Diameter d1 [mm]	Shaft h9 [mm]	iglidur® J E10 [mm]	Housing H7 [mm]
up to 3	0-0.025	+0.014 +0.054	0 +0.010
> 3 to 6	0-0.030	+0.020 +0.068	0 +0.012
> 6 to 10	0-0.036	+0.025 +0.083	0 +0.015
> 10 to 18	0-0.043	+0.032 +0.102	0 +0.018
> 18 to 30	0-0.052	+0.040 +0.124	0 +0.021
> 30 to 50	0-0.062	+0.050 +0.150	0 +0.025
> 50 to 80	0-0.074	+0.060 +0.180	0 +0.030
> 80 to 120	0-0.087	+0.072 +0.212	0 +0.035
> 120 to 180	0-0.100	+0.085 +0.245	0 +0.040

Table 07: Essential tolerances for plain bearings according to ISO 3547-1 after pressfit

iglidur® J | Product Range

Sleeve bearing

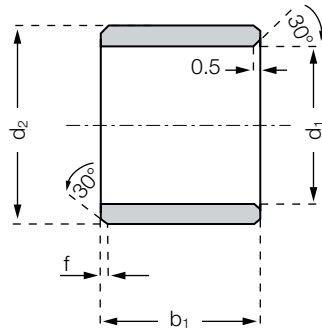

Order key

JSM-0104-02

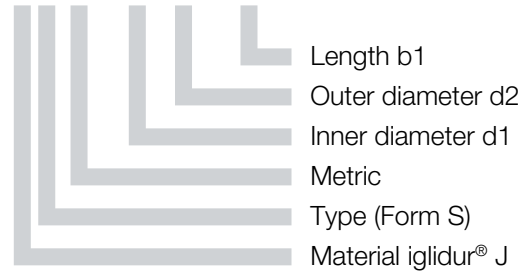

Dimensions according to ISO 3547-1 and special dimensions

Chamfer in relation to the d1

d1 [mm]:	Ø 1-6	Ø 6-12	Ø 12-30	Ø > 30
f [mm]:	0.3	0.5	0.8	1.2

Dimensions [mm]

Part number	d1	d1-Tolerance*	d2	b1 h13
JSM-0104-02	1.5	+0.014 +0.054	4.0	2.0
JSM-0203-07	2.0	+0.014 +0.054	3.5	7.0
JSM-0205-02	2.0	+0.020 +0.080	5.0	2.5
JSM-0206-02	2.5	+0.020 +0.080	6.0	2.5
JSM-0304-05	3.0	+0.014 +0.054	4.5	5.0
JSM-0304-09	3.0	+0.014 +0.054	4.5	9.0
JSM-0305-04	3.0	+0.020 +0.080	5.0	4.0
JSM-0308-04	3.0	+0.020 +0.080	8.0	4.0
JSM-0308-05	3.0	+0.020 +0.080	8.0	5.0
JSM-0405-04	4.0	+0.020 +0.068	5.5	4.0
JSM-0405-08	4.0	+0.020 +0.068	5.5	8.0
JSM-0507-046	5.0	+0.020 +0.068	7.0	4.6
JSM-0507-05	5.0	+0.020 +0.068	7.0	5.0
JSM-0507-10	5.0	+0.020 +0.068	7.0	10.0
JSM-0507-15	5.0	+0.020 +0.080	7.0	15.0
JSM-0607-08	6.0	+0.010 +0.058	7.0	8.0
JSM-0607-12.5	6.0	+0.010 +0.058	7.0	12.5
JSM-0607-14	6.0	+0.010 +0.058	7.0	14.0
JSM-0608-043	6.0	+0.020 +0.068	8.0	4.3
JSM-0608-06	6.0	+0.020 +0.068	8.0	6.0
JSM-0608-08	6.0	+0.020 +0.068	8.0	8.0
JSM-0608-10	6.0	+0.020 +0.068	8.0	10.0
JSM-0609-06	6.0	+0.030 +0.105	9.0	6.0
JSM-0610-10	6.0	+0.030 +0.105	10.0	10.0
JSM-0709-09	7.0	+0.025 +0.083	9.0	9.0

Part number	d1	d1-Tolerance*	d2	b1 h13
JSM-0810-04	8.0	+0.025 +0.083	10.0	4.0
JSM-0810-06	8.0	+0.025 +0.083	10.0	6.0
JSM-0810-08	8.0	+0.025 +0.083	10.0	8.0
JSM-0810-10	8.0	+0.025 +0.083	10.0	10.0
JSM-0810-12	8.0	+0.025 +0.083	10.0	12.0
JSM-0810-16	8.0	+0.025 +0.083	10.0	16.0
JSM-0812-10	8.0	+0.040 +0.130	12.0	10.0
JSM-0812-12	8.0	+0.040 +0.130	12.0	12.0
JSM-1012-05	10.0	+0.025 +0.083	12.0	5.0
JSM-1012-06	10.0	+0.025 +0.083	12.0	6.0
JSM-1012-08	10.0	+0.025 +0.083	12.0	8.0
JSM-1012-10	10.0	+0.025 +0.083	12.0	10.0
JSM-1012-11	10.0	+0.025 +0.083	12.0	11.0
JSM-1012-12	10.0	+0.025 +0.083	12.0	12.0
JSM-1012-15	10.0	+0.025 +0.083	12.0	15.0
JSM-1012-20	10.0	+0.025 +0.083	12.0	20.0
JSM-1014-10	10.0	+0.040 +0.130	14.0	10.0
JSM-1014-16	10.0	+0.040 +0.130	14.0	16.0
JSM-1214-06	12.0	+0.032 +0.102	14.0	6.0
JSM-1214-08	12.0	+0.032 +0.102	14.0	8.0
JSM-1214-09	12.0	+0.032 +0.102	14.0	9.0
JSM-1214-10	12.0	+0.032 +0.102	14.0	10.0
JSM-1214-15	12.0	+0.032 +0.102	14.0	15.0
JSM-1216-12	12.0	+0.050 +0.160	16.0	12.0
JSM-1216-17	12.0	+0.050 +0.160	16.0	17.0

* after pressfit. Testing methods ► page 55

delivery available from stock **prices** price list online www.igus.eu/eu/j

order part number **example** JSM-0104-02



Sleeve bearing

Dimensions [mm]

Part number	d1	d1-Tolerance*	d2	b1 h13
JSM-1416-05	14.0	+0.032 +0.102	16.0	5.0
JSM-1416-08	14.0	+0.032 +0.102	16.0	8.0
JSM-1416-10	14.0	+0.032 +0.102	16.0	10.0
JSM-1416-15	14.0	+0.032 +0.102	16.0	15.0
JSM-1416-20	14.0	+0.032 +0.102	16.0	20.0
JSM-1416-25	14.0	+0.032 +0.102	16.0	25.0
JSM-1418-18	14.0	+0.032 +0.102	18.0	18.0
JSM-1517-12	15.0	+0.032 +0.102	17.0	12.0
JSM-1517-20	15.0	+0.032 +0.102	17.0	20.0
JSM-1618-10	16.0	+0.032 +0.102	18.0	10.0
JSM-1618-12	16.0	+0.032 +0.102	18.0	12.0
JSM-1618-15	16.0	+0.032 +0.102	18.0	15.0
JSM-1618-20	16.0	+0.032 +0.102	18.0	20.0
JSM-1620-16	16.0	+0.050 +0.160	20.0	16.0
JSM-1622-16	16.0	+0.050 +0.160	22.0	16.0
JSM-1622-20	16.0	+0.050 +0.160	22.0	20.0
JSM-1820-15	18.0	+0.032 +0.102	20.0	15.0
JSM-1820-20	18.0	+0.032 +0.102	20.0	20.0
JSM-1922-14	19.0	+0.032 +0.102	22.0	14.0
JSM-2022-20	20.0	+0.040 +0.124	22.0	20.0
JSM-2022-30	20.0	+0.040 +0.124	22.0	30.0
JSM-2023-15	20.0	+0.040 +0.124	23.0	15.0
JSM-2023-20	20.0	+0.040 +0.124	23.0	20.0
JSM-2026-06	20.0	+0.065 +0.195	26.0	6.0
JSM-2026-20	20.0	+0.065 +0.195	26.0	20.0
JSM-2026-25	20.0	+0.065 +0.195	26.0	25.0
JSM-2026-30	20.0	+0.065 +0.195	26.0	30.0
JSM-2427-25	24.0	+0.040 +0.124	27.0	25.0
JSM-2427-46	24.0	+0.040 +0.124	27.0	46.0
JSM-2528-12	25.0	+0.040 +0.124	28.0	12.0

Part number	d1	d1-Tolerance*	d2	b1 h13
JSM-2528-20	25.0	+0.040 +0.124	28.0	20.0
JSM-2528-30	25.0	+0.040 +0.124	28.0	30.0
JSM-2532-25	25.0	+0.065 +0.195	32.0	25.0
JSM-2532-32	25.0	+0.065 +0.195	32.0	32.0
JSM-2532-35	25.0	+0.065 +0.195	32.0	35.0
JSM-2630-20	26.0	+0.065 +0.195	30.0	20.0
JSM-3034-20	30.0	+0.040 +0.124	34.0	20.0
JSM-3034-25	30.0	+0.040 +0.124	34.0	25.0
JSM-3034-30	30.0	+0.040 +0.124	34.0	30.0
JSM-3038-40	30.0	+0.065 +0.195	38.0	40.0
JSM-3236-20	32.0	+0.050 +0.150	36.0	20.0
JSM-3236-30	32.0	+0.050 +0.150	36.0	30.0
JSM-3236-40	32.0	+0.050 +0.150	36.0	40.0
JSM-3539-20	35.0	+0.050 +0.150	39.0	20.0
JSM-3539-30	35.0	+0.050 +0.150	39.0	30.0
JSM-3539-40	35.0	+0.050 +0.150	39.0	40.0
JSM-3640-45	36.0	+0.050 +0.150	40.0	45.0
JSM-4044-30	40.0	+0.050 +0.150	44.0	30.0
JSM-4044-35	40.0	+0.050 +0.150	44.0	35.0
JSM-4044-40	40.0	+0.050 +0.150	44.0	40.0
JSM-4246-73	42.0	+0.080 +0.240	46.0	73.0
JSM-5055-30	50.0	+0.050 +0.150	55.0	30.0
JSM-5055-50	50.0	+0.050 +0.150	55.0	50.0
JSM-5560-60	55.0	+0.060 +0.180	60.0	60.0
JSM-6065-60	60.0	+0.060 +0.180	65.0	60.0
JSM-7580-60	75.0	+0.060 +0.180	80.0	60.0
JSM-8085-100	80.0	+0.060 +0.180	85.0	100.0
JSM-8086-60	80.0	+0.060 +0.180	86.0	60.0
JSM-100105-100	100.0	+0.072 +0.212	105.0	100.0
JSM-100115-60	110.0	+0.072 +0.212	115.0	60.0

* after pressfit. Testing methods ► page 55

iglidur® J | Product Range

Flange bearing

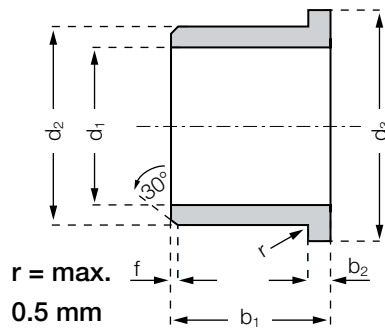

Order key

JFM-0304-05



- Length b1
- Outer diameter d2
- Inner diameter d1
- Metric
- Type (Form F)
- Material iglidur® J

Dimensions according to ISO 3547-1 and special dimensions

Chamfer in relation to the d1

d1 [mm]:	Ø 1-6	Ø 6-12	Ø 12-30	Ø > 30
f [mm]:	0.3	0.5	0.8	1.2

Dimensions [mm]

Part number	d1	d1-Tolerance*	d2	d3 d13	b1 h13	b2 -0.14
JFM-0304-05	3.0	+0.014 +0.054	4.5	7.5	5.0	0.75
JFM-0306-10	3.0	+0.020 +0.080	6.0	9.0	10.0	1.5
JFM-0405-03	4.0	+0.020 +0.068	5.5	9.5	3.0	0.75
JFM-0405-06	4.0	+0.020 +0.068	5.5	9.5	6.0	0.75
JFM-0506-05	5.0	+0.020 +0.068	6.0	10.	5.0	0.5
JFM-0507-05	5.0	+0.020 +0.068	7.0	11.0	5.0	1.0
JFM-0608-04	6.0	+0.020 +0.068	8.0	12.0	4.0	1.0
JFM-0608-06	6.0	+0.020 +0.068	8.0	12.0	6.0	1.0
JFM-0608-08	6.0	+0.020 +0.068	8.0	12.0	8.0	1.0
JFM-0608-10	6.0	+0.020 +0.068	8.0	12.0	10.0	1.0
JFM-0610-10	6.0	+0.030 +0.105	10.0	14.0	10.0	2.0
JFM-0810-038	8.0	+0.025 +0.083	10.0	15.0	3.8	1.0
JFM-0810-05	8.0	+0.025 +0.083	10.0	15.0	5.0	1.0
JFM-0810-06	8.0	+0.025 +0.083	10.0	15.0	6.0	1.0
JFM-0810-07	8.0	+0.025 +0.083	10.0	15.0	7.0	1.0
JFM-0810-08	8.0	+0.025 +0.083	10.0	15.0	8.0	1.0
JFM-0810-10	8.0	+0.025 +0.083	10.0	15.0	10.0	1.0
JFM-0810125-10	8.0	+0.025 +0.083	10.0	12.5	10.0	1.0
JFM-081014-10	8.0	+0.025 +0.083	10.0	14.0	10.0	1.0
JFM-081016-11	8.0	+0.025 +0.083	10.0	16.0	11.0	2.0
JFM-0812-06	8.0	+0.025 +0.083	12.0	16.0	6.0	2.0
JFM-1012-05	10.0	+0.025 +0.083	12.0	18.0	5.0	1.0
JFM-1012-09	10.0	+0.025 +0.083	12.0	18.0	9.0	1.0
JFM-1012-10	10.0	+0.025 +0.083	12.0	18.0	10.0	1.0
JFM-1012-12	10.0	+0.025 +0.083	12.0	18.0	12.0	1.0

* after pressfit. Testing methods ► page 55



delivery available
time from stock



prices price list online
www.igus.eu/eu/j



order part number
example JFM-0304-05



Flange bearing

Dimensions [mm]

Part number	d1	d1-Tolerance*	d2	d3 d13	b1 h13	b2 -0.14
JFM-1012-15	10.0	+0.025 +0.083	12.0	18.0	15.0	1.0
JFM-1012-18	10.0	+0.025 +0.083	12.0	18.0	18.0	1.0
JFM-101215-035	10.0	+0.025 +0.083	12.0	15.0	3.5	1.0
JFM-1014-14	10.0	+0.025 +0.083	14.0	18.0	14.0	1.0
JFM-1113-05	11.0	+0.032 +0.102	13.0	18.0	5.0	1.0
JFM-1214-05	12.0	+0.032 +0.102	14.0	20.0	5.0	1.0
JFM-1214-07	12.0	+0.032 +0.102	14.0	20.0	7.0	1.0
JFM-1214-09	12.0	+0.032 +0.102	14.0	20.0	9.0	1.0
JFM-1214-12	12.0	+0.032 +0.102	14.0	20.0	12.0	1.0
JFM-1214-15	12.0	+0.032 +0.102	14.0	20.0	15.0	1.0
JFM-121418-045	12.0	+0.032 +0.102	14.0	18.0	4.5	1.0
JFM-121418-10	12.0	+0.032 +0.102	14.0	18.0	10.0	1.0
JFM-1218-08	12.0	+0.050 +0.160	18.0	24.0	8.0	3.0
JFM-1218-12	12.0	+0.050 +0.160	18.0	24.0	12.0	3.0
JFM-1218-20	12.0	+0.050 +0.160	18.0	22.0	20.0	3.0
JFM-1416-03	14.0	+0.032 +0.102	16.0	22.0	3.0	1.0
JFM-1416-10	14.0	+0.032 +0.102	16.0	22.0	10.0	1.0
JFM-1416-12	14.0	+0.032 +0.102	16.0	22.0	12.0	1.0
JFM-1416-17	14.0	+0.032 +0.102	16.0	22.0	17.0	1.0
JFM-141822-20	14.0	+0.032 +0.102	18.0	22.0	20.0	2.0
JFM-1517-09	15.0	+0.032 +0.102	17.0	23.0	9.0	1.0
JFM-1517-12	15.0	+0.032 +0.102	17.0	23.0	12.0	1.0
JFM-1517-17	15.0	+0.032 +0.102	17.0	23.0	17.0	1.0
JFM-1521-20	15.0	+0.050 +0.160	21.0	27.0	20.0	3.0
JFM-1618-16	16.0	+0.032 +0.102	18.0	24.0	16.0	1.0
JFM-1618-17	16.0	+0.032 +0.102	18.0	24.0	17.0	1.0
JFM-1622-12	16.0	+0.050 +0.160	22.0	28.0	12.0	3.0
JFM-1622-15	16.0	+0.050 +0.160	22.0	28.0	15.0	3.0
JFM-1719-09	17.0	+0.032 +0.102	19.0	25.0	9.0	1.0
JFM-1719-21	17.0	+0.032 +0.102	19.0	25.0	21.0	1.0
JFM-1820-04	18.0	+0.032 +0.102	20.0	26.0	4.0	1.0
JFM-1820-12	18.0	+0.032 +0.102	20.0	26.0	12.0	1.0
JFM-1820-22	18.0	+0.032 +0.102	20.0	26.0	22.0	1.0
JFM-1922-36	19.0	+0.032 +0.102	22.0	26.0	36.0	1.0
JFM-2023-11	20.0	+0.040 +0.124	23.0	30.0	11.5	1.5
JFM-2023-15.5	20.0	+0.040 +0.124	23.0	30.0	15.5	1.5
JFM-2023-21	20.0	+0.040 +0.124	23.0	30.0	21.5	1.5
JFM-202530-15	20.0	+0.065 +0.195	25.0	30.0	15.0	2.0
JFM-2026-15	20.0	+0.065 +0.195	26.0	32.0	15.0	3.0
JFM-2026-20	20.0	+0.065 +0.195	26.0	32.0	20.0	3.0
JFM-2026-25	20.0	+0.065 +0.195	26.0	32.0	25.0	3.0
JFM-222532-08	22.0	+0.040 +0.124	25.0	32.0	8.0	1.5

* after pressfit. Testing methods ► page 55



Flange bearing

Dimensions [mm]

Part number	d1	d1-Tolerance*	d2	d3 d13	b1 h13	b2 -0.14
JFM-2430-30	24.0	+0.040 +0.124	30.0	36.0	30.0	3.0
JFM-2528-06	25.0	+0.040 +0.124	28.0	35.0	6.0	1.5
JFM-2528-14.5	25.0	+0.040 +0.124	28.0	35.0	14.5	1.5
JFM-2528-21	25.0	+0.040 +0.124	28.0	35.0	21.5	1.5
JFM-252839-075	25.0	+0.040 +0.124	28.0	39.0	7.5	1.5
JFM-2532-20	25.0	+0.065 +0.195	32.0	38.0	20.0	4.0
JFM-2532-25	25.0	+0.065 +0.195	32.0	38.0	25.0	4.0
JFM-283235-07	28.0	+0.065 +0.195	32.0	35.0	7.0	2.0
JFM-3034-20	30.0	+0.040 +0.124	34.0	42.0	20.0	2.0
JFM-3034-26	30.0	+0.040 +0.124	34.0	42.0	26.0	2.0
JFM-3038-30	30.0	+0.065 +0.195	38.0	44.0	30.0	4.0
JFM-3539-12	35.0	+0.050 +0.150	39.0	47.0	12.0	2.0
JFM-3539-16	35.0	+0.050 +0.150	39.0	47.0	16.0	2.0
JFM-3539-26	35.0	+0.050 +0.150	39.0	47.0	26.0	2.0
JFM-4044-20	40.0	+0.050 +0.150	44.0	52.0	20.0	2.0
JFM-4044-30	40.0	+0.050 +0.150	44.0	52.0	30.0	2.0
JFM-4044-40	40.0	+0.050 +0.150	44.0	52.0	40.0	2.0
JFM-4550-20	45.0	+0.050 +0.150	50.0	58.0	20.0	2.0
JFM-4550-50	45.0	+0.050 +0.150	50.0	58.0	50.0	2.0
JFM-5055-50	50.0	+0.050 +0.150	55.0	63.0	50.0	2.0
JFM-5560-50	55.0	+0.060 +0.180	60.0	68.0	50.0	2.0
JFM-6065-50	60.0	+0.060 +0.180	65.0	73.0	50.0	2.0
JFM-7075-50	70.0	+0.060 +0.180	75.0	83.0	50.0	2.0
JFM-9095-100	90.0	+0.072 +0.212	95.0	108.0	100.0	2.5
JFM-110115-100	110.0	+0.072 +0.212	115.0	123.0	100.0	2.5

* after pressfit. Testing methods ► page 55



delivery available
time from stock



prices price list online
www.igus.eu/eu/j



order part number
example JSM-0103-02

Thrust washer

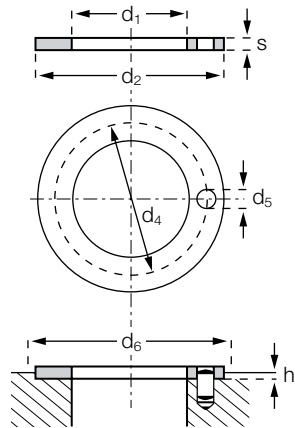
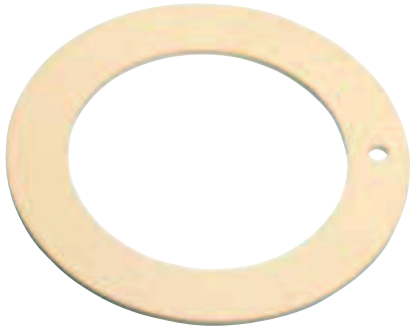

Order key

JTM-1224-015



- Thickness s
- Outer diameter d2
- Inner diameter d1
- Metric
- Type (Form T)
- Material iglidur® J

Dimensions according to ISO 3547-1 and special dimensions

Dimensions [mm]

Part number	d1 +0.25	d2 -0.25	s -0.05	d4 -0.12 +0.12	d5 +0.375 +0.125	h +0.2 -0.2	d6 +0.12
JTM-1224-015	12.0	24.0	1.5	18.0	1.5	1.0	24.0
JTM-2036-015	20.0	36.0	1.5	28.0	3.0	1.0	36.0
JTM-3039-015	30.0	39.0	1.5	**	**	1.0	39.0
JTM-5670-010	56.0	70.0	1.0	**	**	0.7	70.0
JTM-139188-020	139.0	188.0	2.0	**	**	2.0	188.0

** Design without fixing bore



delivery available
time from stock



prices price list online
www.igus.eu/eu/j



order part number
example JTM-1224-015

iglidur® J | Product Range | Inch

Sleeve bearing

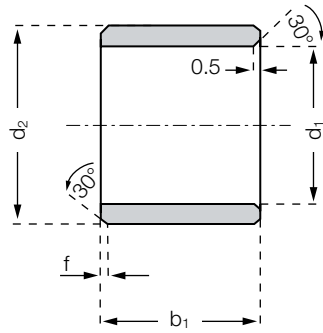

Order key

JSI-0204-04



- Length b1
- Outer diameter d2
- Inner diameter d1
- Metric
- Type (Form S)
- Material iglidur® J

Dimensions according to ISO 3547-1 and special dimensions

Chamfer in relation to the d1

d1 [Inch]:	Ø 0,040–0,236	Ø 0,236–0,472	Ø 0,472–1,18	Ø > 1,18
f [Inch]:	0.012	0.019	0.031	0.047

Dimensions [Inch]

Part number	d1	d2	b1	d1*		Housing Bore		Shaft Size	
				max.	min.	max.	min.	max.	min.
JSI-0204-04	1/8	1/4	1/4	.1280	.1262	.2515	.2510	.1250	.1241
JSI-0204-06	1/8	1/4	3/8	.1280	.1262	.2515	.2510	.1250	.1241
JSI-0304-06	3/16	1/4	3/8	.1892	.1873	.2503	.2497	.1865	.1858
JSI-0304-08	3/16	1/4	1/2	.1892	.1873	.2503	.2497	.1865	.1858
JSI-0305-05	3/16	5/16	5/16	.1905	.1887	.3140	.3135	.1875	.1866
JSI-0305-06	3/16	5/16	3/8	.1905	.1887	.3140	.3135	.1875	.1866
JSI-0305-08	3/16	5/16	1/2	.1905	.1887	.3140	.3135	.1875	.1866
JSI-0405-04	1/4	5/16	1/4	.2521	.2498	.3128	.3122	.2490	.2481
JSI-0405-06	1/4	5/16	3/8	.2521	.2498	.3128	.3122	.2490	.2481
JSI-0405-08	1/4	5/16	1/2	.2521	.2498	.3128	.3122	.2490	.2481
JSI-0406-04	1/4	3/8	1/4	.2539	.2516	.3765	.3760	.2500	.2491
JSI-0406-08	1/4	3/8	1/2	.2539	.2516	.3765	.3760	.2500	.2491
JSI-0406-12	1/4	3/8	3/4	.2539	.2516	.3765	.3760	.2500	.2491
JSI-0406-16	1/4	3/8	1	.2539	.2516	.3765	.3760	.2500	.2491
JSI-0506-06	5/16	3/8	3/8	.3148	.3125	.3753	.3747	.3115	.3106
JSI-0506-08	5/16	3/8	1/2	.3148	.3125	.3753	.3747	.3115	.3106
JSI-0506-12	5/16	3/8	3/4	.3148	.3125	.3753	.3747	.3115	.3106
JSI-0507-06	5/16	7/16	3/8	.3164	.3141	.4390	.4385	.3125	.3116
JSI-0507-08	5/16	7/16	1/2	.3164	.3141	.4390	.4385	.3125	.3116
JSI-0507-10	5/16	7/16	5/8	.3164	.3141	.4390	.4385	.3125	.3116
JSI-0607-06	3/8	15/32	3/8	.3773	.3750	.4691	.4684	.3740	.3731
JSI-0608-03	3/8	1/2	3/16	.3773	.3750	.4691	.4684	.3740	.3731
JSI-0608-06	3/8	1/2	3/8	.3773	.3750	.4691	.4684	.3740	.3731
JSI-0608-08	3/8	1/2	1/2	.3773	.3750	.4691	.4684	.3740	.3731
JSI-0608-10	3/8	1/2	5/8	.3773	.3750	.4691	.4684	.3740	.3731

* after pressfit. Testing methods ► page 55



delivery available
time from stock



prices price list online
www.igus.eu/eu/j



order part number
example JSI-0204-04



Sleeve bearing

Dimensions [Inch]

Part number	d1	d2	b1	d1*		Housing Bore		Shaft Size	
				max.	min.	max.	min.	max.	min.
JSI-0809-06	1/2	19/32	3/8	.5030	.5003	.5941	.5934	.4990	.4980
JSI-0809-08	1/2	19/32	1/2	.5030	.5003	.5941	.5934	.4990	.4980
JSI-0809-12	1/2	19/32	3/4	.5030	.5003	.5941	.5934	.4990	.4980
JSI-0810-08	1/2	5/8	1/2	.5040	.5013	.6260	.6250	.5000	.4990
JSI-0810-12	1/2	5/8	3/4	.5040	.5013	.6260	.6250	.5000	.4990
JSI-1011-08	5/8	23/32	1/2	.6280	.6253	.7192	.7184	.6240	.6230
JSI-1011-12	5/8	23/32	3/4	.6280	.6253	.7192	.7184	.6240	.6230
JSI-1012-04	5/8	3/4	1/4	.6297	.6270	.7510	.7500	.6250	.6240
JSI-1012-06	5/8	3/4	3/8	.6297	.6270	.7510	.7500	.6250	.6240
JSI-1012-08	5/8	3/4	1/2	.6297	.6270	.7510	.7500	.6250	.6240
JSI-1012-12	5/8	3/4	3/4	.6297	.6270	.7510	.7500	.6250	.6240
JSI-1012-16	5/8	3/4	1	.6297	.6270	.7510	.7500	.6250	.6240
JSI-1214-08	3/4	7/8	1/2	.7541	.7505	.8755	.8747	.7491	.7479
JSI-1214-12	3/4	7/8	3/4	.7541	.7505	.8755	.8747	.7491	.7479
JSI-1214-16	3/4	7/8	1	.7541	.7505	.8755	.8747	.7491	.7479
JSI-1216-12	3/4	1	3/4	.7559	.7525	1.0010	1.000	.7500	.7490
JSI-1216-16	3/4	1	1	.7559	.7525	1.0010	1.000	.7500	.7490
JSI-1416-12	7/8	1	3/4	.8791	.8757	1.0005	.9997	.8741	.8729
JSI-1418-12	7/8	11/8	3/4	.8809	.8775	1.1260	1.1250	.8750	.8740
JSI-1418-24	7/8	11/8	11/2	.8809	.8775	1.1260	1.1250	.8750	.8740
JSI-1620-16	1	11/4	1	1.0059	1.0025	1.2510	1.2500	1.0000	.9990
JSI-1620-24	1	11/4	11/2	1.0059	1.0025	1.2510	1.2500	1.0000	.9990
JSI-1822-16	11/8	113/8	1	1.1327	1.1276	1.3760	1.3750	1.1250	1.1240
JSI-2022-14	11/4	113/32	7/8	1.2548	1.2508	1.4068	1.4058	1.2488	1.2472
JSI-2024-24	11/4	11/2	11/2	1.2600	1.2532	1.5005	1.4995	1.2500	1.2490
JSI-2428-24	11/2	13/4	11/2	1.5100	1.5032	1.7505	1.7495	1.5000	1.4990

* after pressfit. Testing methods ► page 55

iglidur® J | Product Range | Inch

Flange bearing

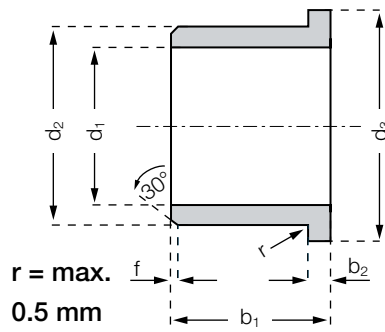

Order key

JFI-0204-04

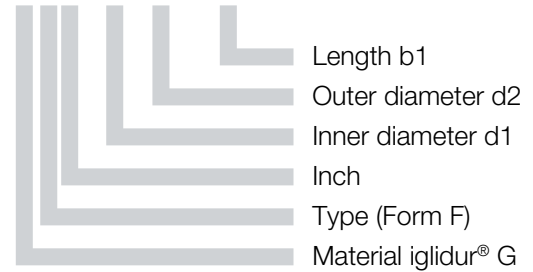

Dimensions according to ISO 3547-1 and special dimensions

Chamfer in relation to the d1

d1 [Inch]:	Ø 0,040–0,236	Ø 0,236–0,472	Ø 0,472–1,18	Ø > 1,18
f [Inch]:	0.012	0.019	0.031	0.047

Dimensions [Inch]

Part number	d1	d2	b1	d3	b2	d1*		Housing Bore		Shaft Size	
						max.	min.	max.	min.	max.	min.
JFI-0204-06	1/8	1/4	3/8	.360	.047	.1280	.1262	.2515	.2510	.1250	.1241
JFI-0304-02	3/16	1/4	1/8	.375	.032	.1905	.1887	.2515	.2510	.1875	.1866
JFI-0304-04	3/16	1/4	1/4	.375	.032	.1892	.1873	.2503	.2497	.1865	.1858
JFI-0304-06	3/16	1/4	3/8	.375	.032	.1892	.1873	.2503	.2497	.1865	.1858
JFI-0304-08	3/16	1/4	1/2	.375	.032	.1892	.1873	.2503	.2497	.1865	.1858
JFI-0305-06	3/16	5/16	3/8	.370	.047	.1905	.1887	.3140	.3135	.1875	.1866
JFI-0305-08	3/16	5/16	1/2	.370	.047	.1905	.1887	.3140	.3135	.1875	.1866
JFI-0405-04	1/4	5/16	1/4	.437	.032	.2521	.2498	.3128	.3122	.2490	.2481
JFI-0405-06	1/4	5/16	3/8	.437	.032	.2521	.2498	.3128	.3122	.2490	.2481
JFI-0405-12	1/4	5/16	3/4	.437	.032	.2521	.2498	.3128	.3122	.2490	.2481
JFI-0406-03	1/4	3/8	3/16	.560	.047	.2539	.2516	.3765	.3760	.2500	.2491
JFI-0406-04	1/4	3/8	1/4	.560	.047	.2539	.2516	.3765	.3760	.2500	.2491
JFI-0406-08	1/4	3/8	1/2	.560	.047	.2539	.2516	.3765	.3760	.2500	.2491
JFI-0506-04	5/16	3/8	1/4	.500	.032	.3148	.3125	.3753	.3747	.3115	.3106
JFI-0506-06	5/16	3/8	3/8	.500	.032	.3148	.3125	.3753	.3747	.3115	.3106
JFI-0506-08	5/16	3/8	1/2	.500	.032	.3148	.3125	.3753	.3747	.3115	.3106
JFI-0507-08	5/16	7/16	1/2	.560	.062	.3164	.3141	.4390	.4385	.3125	.3116
JFI-0607-06	3/8	15/32	3/8	.687	.046	.3772	.3775	.4691	.4684	.3740	.3731
JFI-0608-03	3/8	1/2	3/16	.625	.062	.3789	.3766	.5015	.5010	.3750	.3741
JFI-0608-06	3/8	1/2	3/8	.625	.062	.3789	.3766	.5015	.5010	.3750	.3741
JFI-0608-08	3/8	1/2	1/2	.625	.062	.3789	.3766	.5015	.5010	.3750	.3741
JFI-0809-04	1/2	19/32	1/4	.875	.046	.5040	.5000	.5941	.5934	.4990	.4980
JFI-0809-06	1/2	19/32	3/8	.875	.046	.5040	.5000	.5941	.5934	.4990	.4980
JFI-0809-08	1/2	19/32	1/2	.875	.046	.5040	.5000	.5941	.5934	.4990	.4980
JFI-0810-04	1/2	5/8	1/4	.875	.062	.5047	.5020	.6260	.6250	.5000	.4990

* after pressfit. Testing methods ► page 55



delivery available
time from stock



prices price list online
www.igus.eu/eu/j



order part number
example JFI-0204-06



Flange bearing

Dimensions [Inch]

Part number	d1	d2	b1	d3	b2	d1*		Housing Bore		Shaft Size	
						max.	min.	max.	min.	max.	min.
JFI-0810-08	1/2	5/8	1/2	.875	.062	.5047	.5020	.6260	.6250	.5000	.4990
JFI-0810-10	1/2	5/8	5/8	.875	.062	.5047	.5020	.6260	.6250	.5000	.4990
JFI-0810-12	1/2	5/8	3/4	.875	.062	.5047	.5020	.6260	.6250	.5000	.4990
JFI-1011-08	5/8	23/32	1/2	.937	.046	.6280	.6253	.7192	.7184	.6240	.6230
JFI-1011-12	5/8	23/32	3/4	1.000	.046	.6297	.6270	.7192	.7184	.6250	.6240
JFI-1012-08	5/8	3/4	1/2	1.000	.062	.6297	.6270	.7510	.7500	.6250	.6240
JFI-1012-12	5/8	3/4	3/4	1.000	.062	.6297	.6270	.7510	.7500	.6250	.6240
JFI-1012-16	5/8	3/4	1	1.000	.062	.6297	.6270	.7510	.7500	.6250	.6240
JFI-1214-08	3/4	7/8	1/2	1.125	.062	.7541	.7505	.8755	.8747	.7491	.7479
JFI-1214-10	3/4	7/8	5/8	1.125	.062	.7541	.7505	.8755	.8747	.7491	.7479
JFI-1214-12	3/4	7/8	3/4	1.125	.062	.7541	.7505	.8755	.8747	.7491	.7479
JFI-1214-16	3/4	7/8	1	1.125	.062	.7541	.7505	.8755	.8747	.7491	.7479
JFI-1216-12	3/4	1	3/4	1.250	.156	.7559	.7525	1.0010	1.0000	.7500	.7490
JFI-1216-16	3/4	1	1	1.250	.156	.7559	.7525	1.0010	1.0000	.7500	.7490
JFI-1416-12	7/8	1	3/4	1.250	.062	.8791	.8757	1.0005	.9997	.8741	.8729
JFI-141618-11	7/8	1	11/16	1.125	.062	.8809	.8776	1.0010	1.0000	.8750	.8740
JFI-1618-12	1	11/8	3/4	1.375	.062	1.0041	1.0007	1.1255	1.1247	.9991	.9979
JFI-1618-16	1	11/8	1	1.375	.062	1.0041	1.0007	1.1255	1.1247	.9991	.9979
JFI-1620-12	1	11/4	3/4	1.500	.188	1.0059	1.0025	1.2510	1.2500	1.0000	.9990
JFI-1620-16	1	11/4	1	1.500	.188	1.0059	1.0025	1.2510	1.2500	1.0000	.9990
JFI-1620-24	1	11/4	11/2	1.500	.188	1.0059	1.0025	1.2510	1.2500	1.0000	.9990
JFI-2024-16	11/4	11/2	1	1.750	.188	1.2600	1.2531	1.5005	1.4995	1.2500	1.2490
JFI-2024-24	11/4	11/2	11/2	1.750	.188	1.2600	1.2531	1.5005	1.4995	1.2500	1.2490
JFI-2428-16	11/2	13/4	1	2.000	.125	1.5100	1.5032	1.7505	1.7495	1.5000	1.4990
JFI-2428-24	11/2	13/4	11/2	2.000	.125	1.5100	1.5032	1.7505	1.7495	1.5000	1.4990
JFI-2630-16	15/8	17/8	1	2.125	.125	1.6350	1.6882	1.8755	1.8745	1.6250	1.6240

* after pressfit. Testing methods ► page 55