

drylin® Shafts



7 shaft materials to choose

All shafts also in supported versions

Aluminium for low weight

Stainless steel for high corrosion resistance

Special machining

Available from stock

Diameters 6–50 mm

drylin® Shafts

Suitable liner materials:

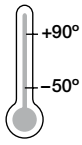

The all rounder – iglidur® J
▶ page 93

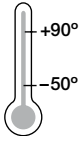

The specialist – iglidur® J200
▶ page 279

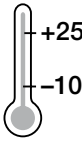

The extreme – iglidur® X
▶ page 157



Aluminum

- Low weight
- Lower wear of the plain bearing
- Corrosion resistant
- Ideal in combination with liners made of iglidur® J/J200
- Delivered ex-stock

Steel

- Low-priced standard
- High load capacity
- Application in dry area
- Hard chrome-plated also available
- Lower coefficient of friction against plastic bearing

Stainless Steel

- High corrosion resistance
- High resistance to chemicals
- Ideal solution for the wet area
- 316 for extreme chemical intensive applications

Wear

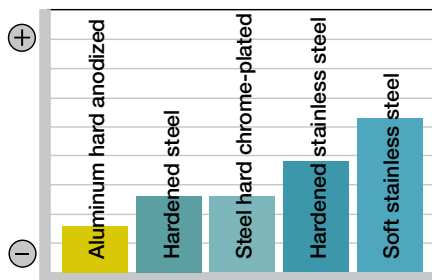

igidur® J against particular shaft materials

Coefficient of friction

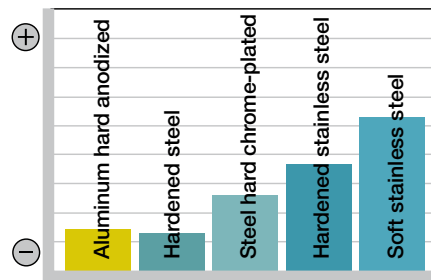

igidur® J against particular shaft materials

Corrosion

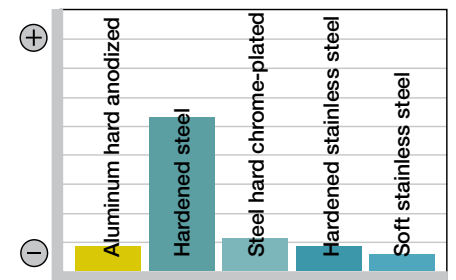

Weight

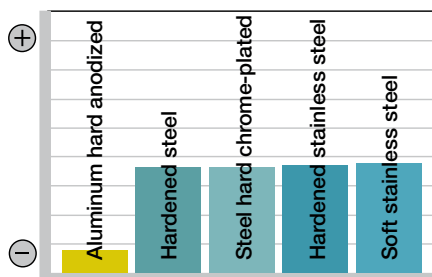

Costs

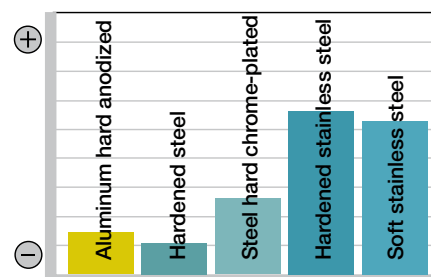

Chemical resistance

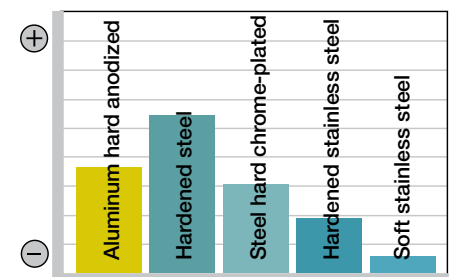

Designation	Aluminum			Steel				Stainless steel, hardened				SS, soft	
	AWMP	AWMU	AWMR	SWM	SWUMN	SWMH	SWUMHN	EWM	EWUMN	EEWM	EEWUMN	EWMR	EWMS
Material	EN AW 6061/6060			1.1213		1.1213 HV		1.4125		1.4034		1.4301	1.4571
Ø 6	●			▲		▲		▲ ²		▲			
Ø 8	●			▲		▲		▲ ²		▲			
Ø 10	●	●		▲		▲		▲ ²		▲		▲	▲
Ø 12	●	●		▲	▲	▲	▲	▲	▲	▲	▲	▲	■
Ø 16	●	●		▲	▲	▲	▲	▲	▲	▲	▲	▲	■
Ø 20	●	●	●	▲	▲	▲	▲	▲	▲	▲	▲	▲	▲
Ø 25	●	●	●	▲	▲	▲	▲	▲	▲	▲	▲	▲	■
Ø 30	● ¹	●		▲	▲	▲	▲	▲	▲	▲	▲	▲	■
Ø 40	● ¹	●		▲	▲	▲	▲	▲	▲	▲			
Ø 50	● ¹			▲	▲	▲	▲	▲	▲	▲			
Ø Tolerance	h8	-0.1	h9	h6	h6	h7	h7	h6	h6	h6	h6	h9	h9
Max. supply length Ø 8-10	3,000			3,000		3,000				3,000			
Max. supply length Ø 12-50	3,000	4,000	3,000	6,000	6,000	6,000	6,000	6,000	6,000	6,000	6,000	3,000	3,000
Surface	hard anodized			hardened/ smoothend		hard chrome-plated		hardened/ smoothend		hardened/ smoothend		drawn	
Surface Roughness Ra	< 0.6			0.15-0.3		0.15-0.3		0.15-0.3		0.15-0.3		0.3-0.6	
Surface hardness	450-550 HV			60+4 HRC		60+4 HRC		52+8 HRC		52+8 HRC		soft	
Roundness	≤ 1/2 Ø Tolerance			≤ 1/2 Ø Tolerance		≤ 1/2 Ø Tolerance		≤ 1/2 Ø Tolerance		≤ 1/2 Ø Tolerance		≤ 1/2 Ø Tolerance	

Delivery time ● ex-stock ▲ 3-14 days ■ on request ¹ Hollow profile 30 · 7.5; 40 · 10; 50 · 11 ² Material 1.4112

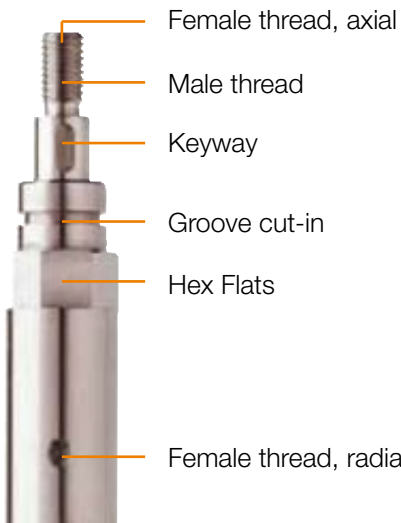

Special Machining

All shafts can be individually machined. Please send us your drawing. We'll submit you a quote in a short time. Query form ► [page 964](#)

Queries can also be sent online:

► www.igus.eu/shaftinquiry

Precision Aluminum Shafts

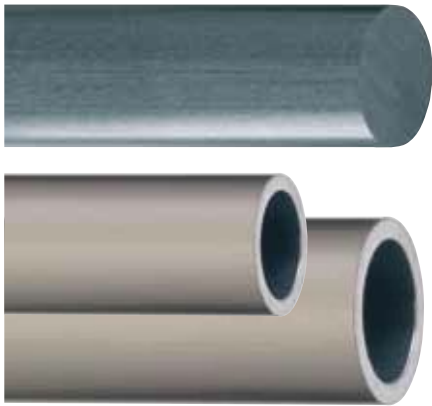

Order key

AWMP-06-...

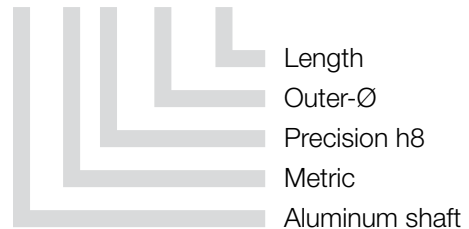

- The recommended shaft material for all linear bearings made from iglidur® J and iglidur® J200
- Material: EN AW 6061/6060
- Straightness: EN 754-3
- Hardness: 75 HB
- Surface: hartanodisiert
- Surface hardness: 450–550 HV
- Inch-dimensions on request

Please remember that this is a technical surface. Small colour variations are possible due to variable coating depths.



Hard anodized surfaces

▶ page 788

Dimensions [mm]

Part number	Version	Outer diameter	Tolerance	Insulation thickness	Inner diameter	Max. length	Weight [kg/m]
AWMP-06	solid shaft	6	h8	–	–	3,000	0.08
AWMP-08	solid shaft	8	h8	–	–	3,000	0.14
AWMP-10	solid shaft	10	h8	–	–	3,000	0.22
AWMP-12	solid shaft	12	h8	–	–	3,000	0.32
AWMP-16	solid shaft	16	h8	–	–	3,000	0.56
AWMP-20	solid shaft	20	h8	–	–	3,000	0.88
AWMR-20	hollow shaft	20	h9	2	16	3,000	0.32
AWMP-25	solid shaft	25	h8	–	–	3,000	1.37
AWMR-25	hollow shaft	25	h9	3	19	3,000	0.59
AWMP-30	hollow shaft	30	h8	7.5	15	3,000	1.48
AWMP-40	hollow shaft	40	h8	10	20	3,000	2.63
AWMP-50	hollow shaft	50	h8	11	28	3,000	3.75

Order example: AWMP-12-500 corresponds to a precision aluminum shaft Ø 12 mm, 500 mm in length.



delivery from stock
time



prices price list online
www.igus.eu/shafts

drylin® Shafts | Product Range

Supported Aluminum Shaft



Order key

AWMU-12-...

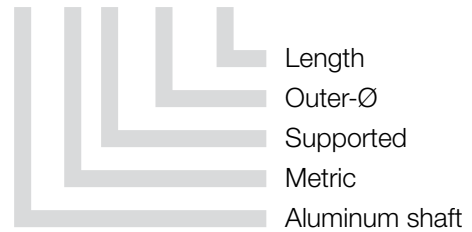

- Material: EN AW 6061/6060
- Straightness: DIN 12020
- Hardness: 75 HB
- Surface: hartanodisiert
- Surface hardness: 450-550 HV
- Hole pitches symmetrical C5 = C6

Please remember that this is a technical surface. Small colour variations are possible due to variable coating depths.



Hard anodized surfaces

▶ page 788

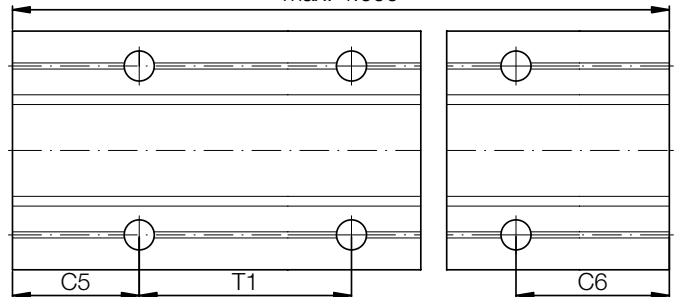
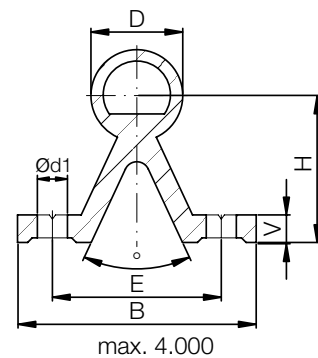

Dimensions [mm]

Part number	D	B	H	V	d1	(°)	E	T1	C5/C6		Max. length	Weight [kg/m]
	-0.1		±0.25				±0.25		min.	max.		
AWMU-12	12	40	22	5	4.5	50	29	75	20	57	4,000	0.75
AWMU-16	16	45	26	5	5.5	50	33	100	20	69	4,000	1.00
AWMU-20	20	52	32	6	6.6	50	37	100	20	69	4,000	1.42
AWMU-25	25	57	36	6	6.6	50	42	120	20	79	4,000	1.81
AWMU-30	30	69	42	7	9.0	50	51	150	20	94	4,000	2.69
AWMU-40*	40	73	50	8	9.0	50	55	200	20	119	4,000	4.06

Order example: AWMU-16-500 corresponds to a supported aluminum shaft Ø 16 mm, 500 mm in length.

* Tolerance for shaft diameter D is -0.15.



delivery from stock
time



prices price list online
www.igus.eu/shafts

Steel Shafts



Order key

SWM-06-...

Cf53

- Low-priced standard shafts
- Even totally supported with standard aluminum support
- Available shaft materials:
 - ▶ Cf53 steel (1.1213), hardened/smoothed
 - ▶ Cf53 steel (1.1213 HV), hard chromed
- For supported shafts:
 - ▶ Shaft support supplied in lengths of 600 mm max.
 - ▶ Two hole pitches are available, T2 (standard) or T1
 - ▶ Hole pitches symmetrical C5 = C6

Dimensions [mm] – Steel Shafts 1.1213

Part number	d	Weight [kg/m]	Max. length	Effective hardness depth (at 1.1213)
SWM-06	06	0.222	3,000	0.8
SWM-08	08	0.359	4,000	0.9
SWM-10	10	0.617	4,000	0.9
SWM-12	12	0.888	6,000	1.0
SWM-16	16	1.578	6,000	1.2
SWM-20	20	2.466	6,000	1.6
SWM-25	25	3.853	6,000	1.8
SWM-30	30	5.549	6,000	2.0
SWM-40	40	9.865	6,000	2.2
SWM-50	50	15.413	6,000	2.4

Dimensions [mm] – Hard chromed Steel Shafts 1.1213

Part number	d	Weight [kg/m]	Max. length	Effective hardness depth (at 1.1213)
SWMH-06	06	0.222	3,000	0.8
SWMH-08	08	0.359	4,000	0.9
SWMH-10	10	0.617	4,000	0.9
SWMH-12	12	0.888	6,000	1.0
SWMH-16	16	1.578	6,000	1.2
SWMH-20	20	2.466	6,000	1.6
SWMH-25	25	3.853	6,000	1.8
SWMH-30	30	5.549	6,000	2.0
SWMH-40	40	9.865	6,000	2.2
SWMH-50	50	15.413	6,000	2.4

Order example: SWM-16-500 corresponds to a steel shaft 16 mm Ø 1.1213, 500 mm in length.

Supported Steel Shaft

SWUM

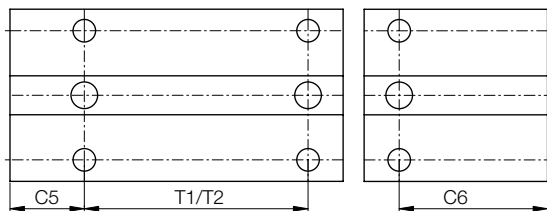
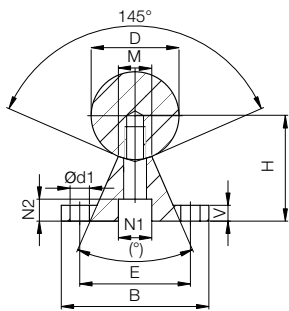

SWUMN

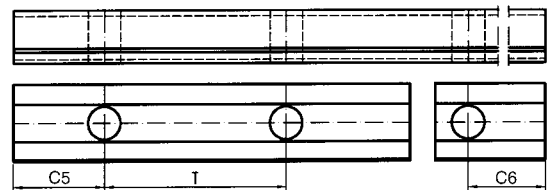
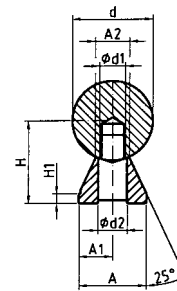

Dimensions [mm] – Supported Steel Shafts 1.1213

Part number	D	B	H	V	N1	N2	d1	M	(°)	E	T1*	C5/C6		T2	C5/C6		Weight
												min.	max.		min.	max.	
			±0.02								±0.15	for T1	Standard		for T2	Standard	
SWUM-12	12	40	22	5	8.0	5.0	4.5	5.8	50	29	75	20	57	120	20	79	1.75
SWUM-16	16	45	26	5	9.5	6.0	5.5	7.0	50	33	100	20	69	150	20	94	2.64
SWUM-20	20	52	32	6	11.0	6.5	6.6	8.3	50	37	100	20	69	150	20	94	3.97
SWUM-25	25	57	36	6	14.0	8.5	6.6	10.8	50	42	120	20	79	200	20	119	5.65
SWUM-30	30	69	42	7	17.0	10.5	9.0	11.0	50	51	150	20	94	200	20	119	7.93
SWUM-40	40	73	50	8	17.0	10.5	9.0	15.0	50	55	200	20	119	300	20	169	12.88
SWUM-50	50	84	60	9	19.0	12.5	11.0	19.0	46	63	200	20	119	300	20	169	19.60

* Two hole pitches are available, T2 (standard) or T1

Dimensions [mm] – Low Level Supported Steel Shafts 1.1213

Part number	d	H	H1	A	A1	A2	d1	d2	T	C5/C6		Weight
										min.	max.	
			±0.02			±0.02						
SWUMN-12	12	14.5	3	11	5.5	5.4	M4	4.5	75	20	57	1.62
SWUMN-16	16	18	3	14	7.0	7.0	M5	5.5	75	20	57	2.54
SWUMN-20	20	22	3	17	8.5	8.1	M6	6.6	75	20	57	3.81
SWUMN-25	25	26	3	21	10.5	10.3	M8	9.0	75	20	57	5.62
SWUMN-30	30	30	3	23	11.5	11.0	M10	11.0	100	20	69.5	7.63
SWUMN-40	40	39	4	30	15.0	15.0	M12	13.5	100	20	69.5	13.47
SWUMN-50	50	46	5	35	17.5	19.0	M14	15.5	100	20	69.5	20.31

Low level supported shafts are delivered unmounted.

Order example: SWUM-16-500 corresponds to a supported steel shaft 16 mm ø aus 1.1213, 500 mm in length.



Stainless Steel Shafts



Order key

EWM-06-...

Length

Outer-Ø

Metric

Material: stainless steel

EWM – 1.4125

EEWM – 1.4034

EWMR – 1.4301

EWMS – 1.4571

- Available shaft materials:
 - Stainless steel (1.4125), hardened/smoothed
 - Stainless steel (1.4034), hardened/smoothed
 - Stainless steel (1.4301 oder 1.4571), drawn
 - Stainless steel (1.4112), hardened/smoothed
- Even totally supported with standard aluminum support

- For supported shafts:
 - ▶ Shaft support supplied in lengths of 600 mm max.
 - ▶ Two hole pitches are available, T2 (standard) or T1
 - ▶ Hole pitches symmetrical C5 = C6



Dimensions [mm] – Hardened Stainless Steel 1.4125

Part number	d	Weight [kg/m]	Max. length	Effective hardness depth (at 1.4125)
EWM-06*	06	0.222	3,000	0.8
EWM-08*	08	0.359	4,000	0.9
EWM-10*	10	0.617	4,000	0.9
EWM-12	12	0.888	6,000	1.0
EWM-16	16	1.578	6,000	1.2
EWM-20	20	2.466	6,000	1.6
EWM-25	25	3.853	6,000	1.8
EWM-30	30	5.549	6,000	2.0
EWM-40	40	9.865	6,000	2.2
EWM-50	50	15.413	6,000	2.4

* Material X90 (1.4112)

delivery 3–8 days
timeprices price list online
www.igus.eu/shafts

Stainless Steel Shafts

Dimensions [mm] – Hardened Stainless Steel 1.4034

Part number	d	Weight [kg/m]	Max. length	Effective hardness depth (at 1.4034)
EEWM-06	06	0.222	3,000	0.8
EEWM-08	08	0.359	4,000	0.9
EEWM-10	10	0.617	4,000	0.9
EEWM-12	12	0.888	6,000	1.0
EEWM-16	16	1.578	6,000	1.2
EEWM-20	20	2.466	6,000	1.6
EEWM-25	25	3.853	6,000	1.8
EEWM-30	30	5.549	6,000	2.0
EEWM-40	40	9.865	6,000	2.2
EEWM-50	50	15.413	6,000	2.4



Dimensions [mm] – Stainless Steel 1.4301 (EWMR) or 1.4571 Soft Stainless Steel (EWMS)

Part number	d	Weight [kg/m]	Max. length
EWMR-10	10	0.617	4,000
EWMS-10	10	0.617	4,000
EWMR-12	12	0.888	6,000
EWMR-16	16	1.578	6,000
EWMR-20	20	2.466	3,000
EWMS-20	20	2.466	6,000
EWMR-25	25	3.853	6,000
EWMR-30	30	5.549	6,000

Order example: EWM-16-500 corresponds to a stainless steel shaft 16 mm Ø 1.4125, 500 mm in length.



delivery 3–8 days
time



prices price list online
www.igus.eu/shafts

Supported Stainless Steel Shafts

EWUM

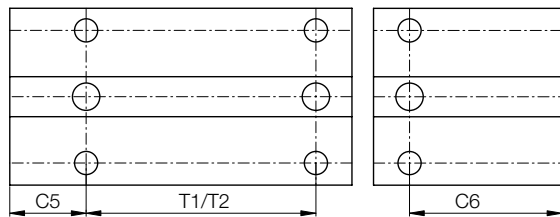
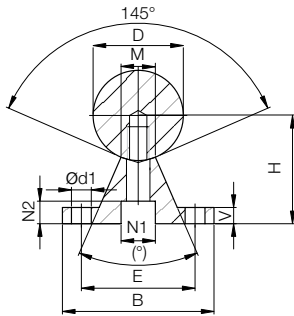

EWUMN

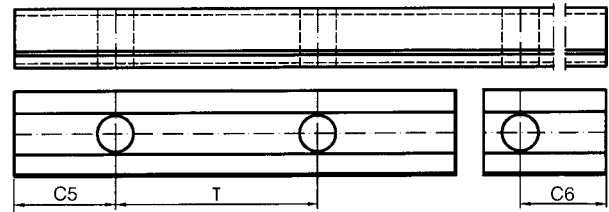
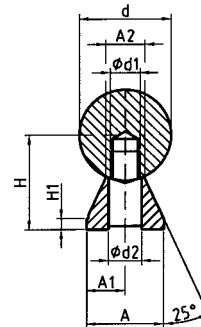

Dimensions [mm] – Supported Stainless Steel Shafts 1.4125

Part number	D	B	H	V	N1	N2	d1	M	(°)	E	T1*	C5/C6		T2	C5/C6		Weight
												min.	max.		min.	max.	
			±0.02								±0.15	for T1	Standard	Standard		[kg/m]	
EWUM-12	12	40	22	5	8.0	5.0	4.5	5.8	50	29	75	20	57	120	20	79	1.75
EWUM-16	16	45	26	5	9.5	6.0	5.5	7.0	50	33	100	20	69	150	20	94	2.64
EWUM-20	20	52	32	6	11.0	6.5	6.6	8.3	50	37	100	20	69	150	20	94	3.97
EWUM-25	25	57	36	6	14.0	8.5	6.6	10.8	50	42	120	20	79	200	20	119	5.65
EWUM-30	30	69	42	7	17.0	10.5	9.0	11.0	50	51	150	20	94	200	20	119	7.93
EWUM-40	40	73	50	8	17.0	10.5	9.0	15.0	50	55	200	20	119	300	20	169	12.88
EWUM-50	50	84	60	9	19.0	12.5	11.0	19.0	46	63	200	20	119	300	20	169	19.60

* Two hole pitches are available, T2 (standard) or T1

Dimensions [mm] – Low Level Supported Stainless Steel Shafts 1.4125

Part number	d	H	H1	A	A1	A2	d1	d2	T	C5/C6		Weight
										min.	max.	
		±0.02				±0.02						[kg/m]
EWUMN-12	12	14.5	3	11	5.5	5.4	M4	4.5	75	20	57	1.62
EWUMN-16	16	18	3	14	7.0	7.0	M5	5.5	75	20	57	2.54
EWUMN-20	20	22	3	17	8.5	8.1	M6	6.6	75	20	57	3.81
EWUMN-25	25	26	3	21	10.5	10.3	M8	9.0	75	20	57	5.62
EWUMN-30	30	30	3	23	11.5	11.0	M10	11.0	100	20	69.5	7.63
EWUMN-40	40	39	4	30	15.0	15.0	M12	13.5	100	20	69.5	13.47
EWUMN-50	50	46	5	35	17.5	19.0	M14	15.5	100	20	69.5	20.31

Low level supported shafts are delivered unmounted.

Order example: EWUMN-16-500 corresponds to a low level supported stainless steel shaft (1.4125) 16 mm Ø, 500 mm in length.



drylin® Shafts | Product Range

Partially supported stainless steel shafts

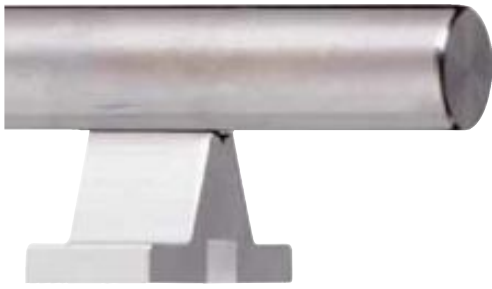

EWUM-ES-20-...

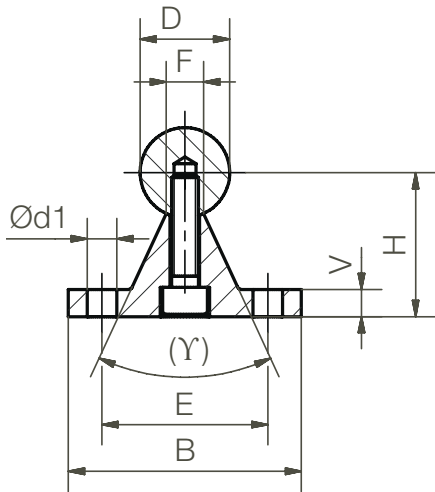
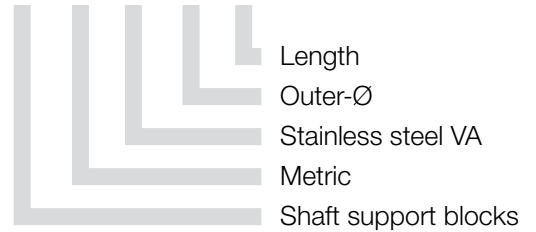

Shaft support blocks for Ø 20 mm made of stainless steel VA

- Connecting dimensions as standard shaft supports in aluminum
- High corrosion and chemical resistance
- Best addition for stainless steel shafts
- Available stainless steel shafts in 1.4571 and 1.4125
- Possible lengths:
 - EWUM (1.4125) max. 6,000 mm
 - EWUMS (1.4571) max. 3,000 mm

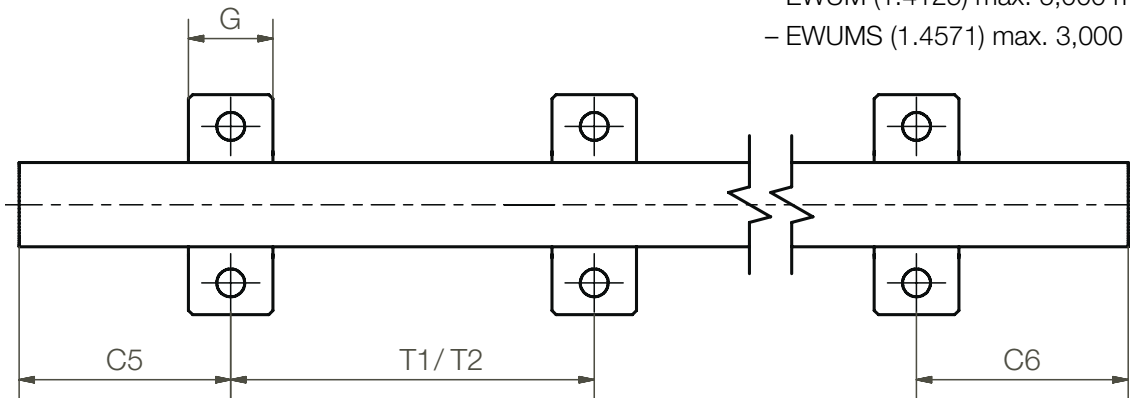

Dimensions [mm]

Part number	Shaft material	D h6	B ±0.02	H	V	d1	E	γ	F	G	T1	C5/C6 for T1		T2	C5/C6 for T2	
												min.	max.		min.	max.
EWUM-ES-20	1.4125	20	52	32	6	6.6	37	50°	8.3	20	100	20	69	150	20	94
EWUMS-ES-20	1.4571	20	52	32	6	6.6	37	50°	8.3	20	100	20	69	150	20	94



delivery 3–8 days
time



prices price list online
www.igus.eu/shafts

Carbon Fibre Shaft



Order key

CWM-12-...



Length

Outer-Ø

Metric

Carbon Fibre Shaft

- Material: Carbon fibre
- Roundness Tolerance: ± 0.05 mm
- Tolerance of diameter: $-0,1$ mm
- Application temperature: max. $+80^{\circ}\text{C}$
- Colour: Black
- Shafts and mounting accessories on request



Hard anodized surfaces

► page 788

Dimensions [mm]

Part number	Version	Diameter	Max. length	Weight
		-0.1		[g]
CWM-12	Hollow	12/9	2,000 mm	7
CWM-16	Hollow	16/12.5	2,000 mm	120
CWM-20	Hollow	20/16	2,000 mm	170
CWM-30	Hollow	30/26	2,000 mm	270

Order example: CWM-12, 500 corresponds to a carbon fibre shaft \varnothing 12 mm, 500 mm in length.



delivery on request
time



prices price list online
www.igus.eu/shafts

drylin® Shafts | Product Range

Shaft End Support, Movable



Order key

TA-08

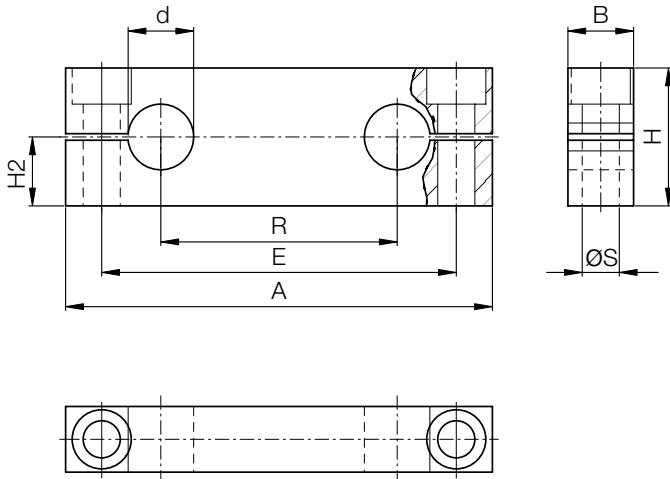

Inner-Ø

Shaft end support,
movable

Material: Aluminum

Threaded fixing bore



Hard anodized surfaces

► page 788

Dimensions [mm]

Part number	d	A	B	H	H2 ±0.015	ø S	E	R	Weight [g]
TA-08	8	65	12	22	11	M5	52	32	40
TA-12	12	85	14	28	14	M6	70	42	70
TA-16	16	100	18	32	16	M8	82	54	130
TA-20	20	130	20	42	21	M10	108	72	220
TA-25	25	160	25	52	26	M12	132	88	440
TA-30	30	180	25	58	29	M12	150	96	560
TA-40	40	230	30	72	36	M16	190	122	1,000

delivery from stock
timeprices price list online
www.igus.eu/shafts

Shaft End Support, Fixed



Order key

TAF-08

Inner-Ø

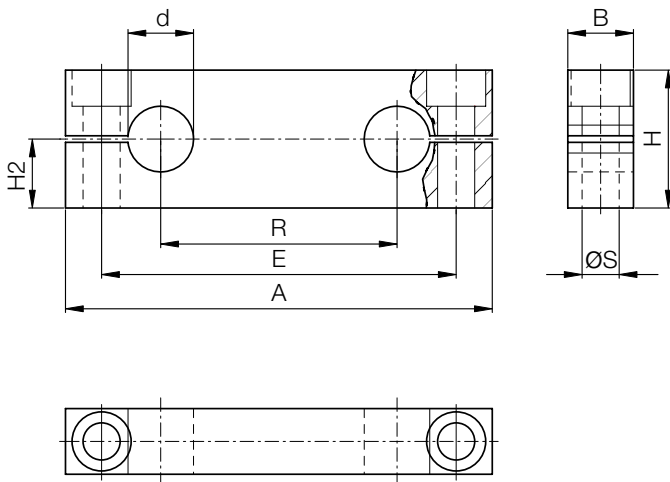
Shaft end support,
fixed**Material: Aluminum**
mounting hole

Dimensions [mm]

Part number	d	A	B	H	H2 ±0.015	R	Ø S	E	Weight [g]
TAF-08	8	65	12	23	12.5	32	5.5	52	40
TAF-12	12	85	14	32	18.0	42	6.6	70	90
TAF-16	16	100	18	36	20.0	54	9.0	82	140
TAF-20	20	130	20	46	25.0	72	11.0	108	250
TAF-25	25	160	25	56	30.0	88	13.5	132	470
TAF-30	30	180	25	64	35.0	96	13.5	150	620
TAF-40	40	230	30	80	44.0	122	17.5	190	1,150

**delivery** from stock
time**prices** price list online
www.igus.eu/shafts

drylin® Shafts | Product Range

Shaft End Block, Standard Design



Order key

WA-08

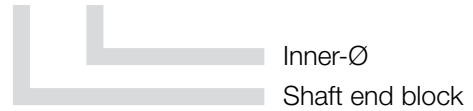

Inner-Ø

Shaft end block

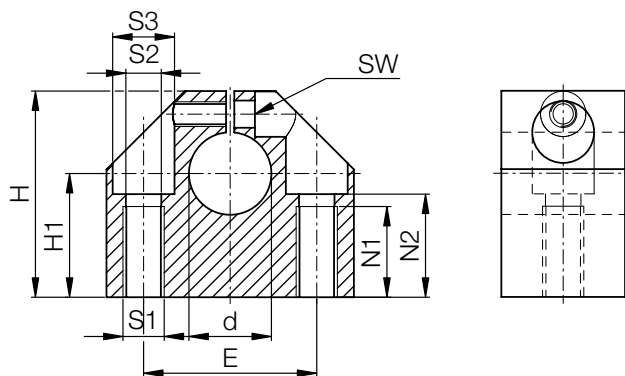

Material: Aluminum

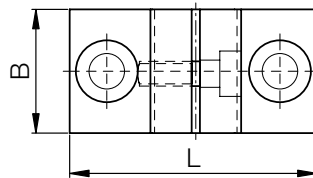

Dimensions [mm]

Part number	d	B	H	H1	L	S1	S2	S3	E	N1	N2	SW	Weight [g]
WA-08	8	18	28	15	32	M4	3.3	6	22	9	13.0	2.5	40
WA-12	12	20	35	20	43	M6	5.2	10	30	13	16.5	3.0	100
WA-16	16	24	42	25	53	M8	6.8	11	38	18	21.0	4.0	150
WA-20	20	30	50	30	60	M10	8.6	15	42	22	25.0	5.0	230
WA-25	25	38	60	35	78	M12	10.3	18	56	26	30.0	6.0	410
WA-30	30	40	70	40	87	M12	10.3	18	64	26	34.0	6.0	530
WA-40	40	48	90	50	108	M16	14.25	20	82	34	44.0	8.0	990
WA-50	50	58	105	60	132	M20	17.5	26	100	43	49.0	10.0	1,250



delivery from stock
time on request



prices price list online
www.igus.eu/shafts

Shaft End Block, Compact Design



Order key

WAC-06



Inner-Ø
Shaft end block,
Compact design

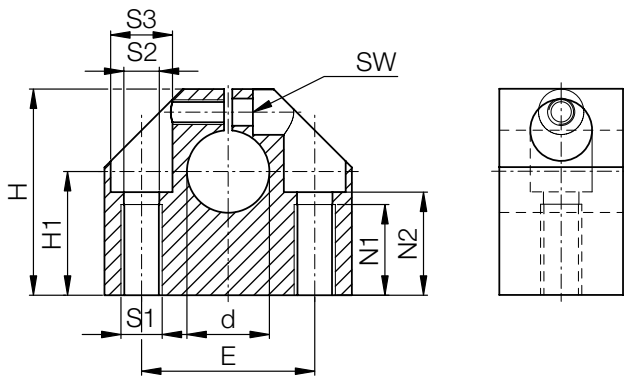

Material: Aluminum

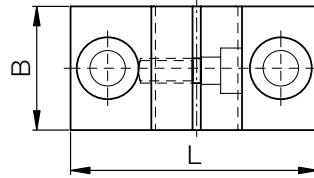

Hard anodized surfaces

► page 788

Dimensions [mm]

Part number	d	B	H	H1	L	S1	S2	S3	E	N1	N2	SW	Weight [g]
				+0.01 up to +0.02					±0.1				
WAC-06	6	16	27	15	32	M5	4.2	8	22	11	13	2.5	30
WAC-08	8	16	27	16	32	M5	4.2	8	22	11	13	2.5	30
WAC-10	10	18	33	18	40	M6	5.2	10	27	13	16	3.0	50
WAC-12	12	18	33	19	40	M6	5.2	10	27	13	16	3.0	50
WAC-14	14	20	38	20	45	M6	5.2	10	32	13	18	3.0	70
WAC-16	16	20	38	22	45	M6	5.2	10	32	13	18	3.0	70
WAC-20	20	24	45	25	53	M8	6.8	11	39	18	22	4.0	120
WAC-25	25	28	54	31	62	M10	8.6	15	44	22	26	5.0	170
WAC-30	30	30	60	34	67	M10	8.6	15	49	22	29	5.0	220
WAC-40	40	40	76	42	87	M12	10.3	18	66	26	38	6.0	480
WAC-50	50	50	92	50	103	M16	14.25	20	80	34	46	8.0	820



delivery from stock
time on request



prices price list online
www.igus.eu/shafts

drylin® Shafts | Product Range

Shaft End Block, Narrow Design



Order key

WAS-08

Inner-Ø
Shaft end block,
narrow design

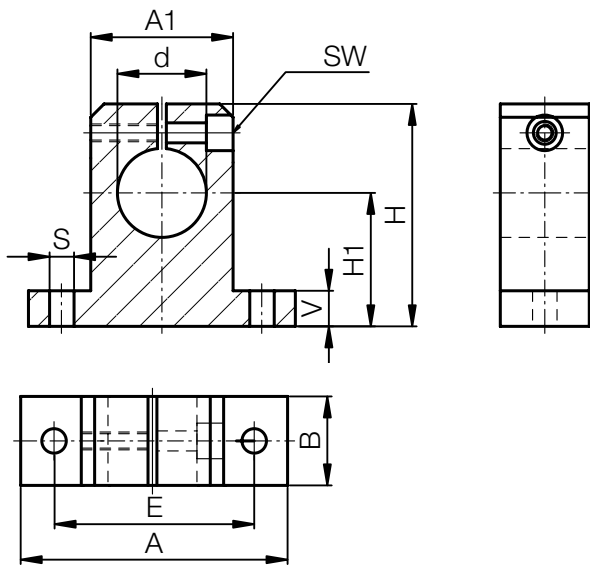

Material: Aluminum



Hard anodized surfaces
▶ page 788

Dimensions [mm]

Part number	d	H	H1 ±0.02	A	A1	B	E	S	V	SW	Weight [g]
WAS-08	8	27	15	32	16	10	25	4.5	5.0	2.5	12
WAS-12	12	35	20	42	20	12	32	5.5	5.5	3.0	23
WAS-16	16	42	25	50	26	16	40	5.5	6.5	3.0	35
WAS-20	20	50	30	60	32	20	45	5.5	8.0	4.0	67
WAS-25	25	58	35	74	38	25	60	6.6	9.0	4.0	140
WAS-30	30	68	40	84	45	28	68	9.0	10.0	5.0	200
WAS-40	40	86	50	108	56	32	86	11.0	12.0	6.0	480



delivery from stock
time



prices price list online
www.igus.eu/shafts

Shaft End Block



Order key

WAF-12

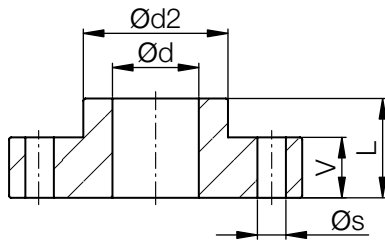
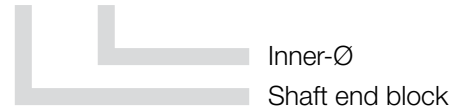

Material: Aluminum



Hard anodized surfaces

► page 788

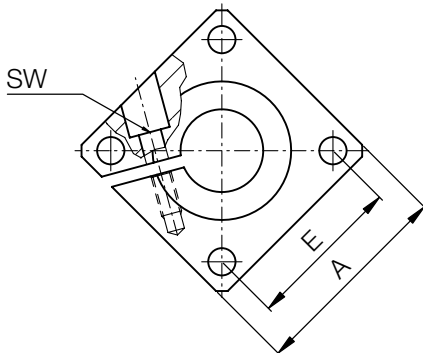

Dimensions [mm]

Part number	Ø d	A	L	Ø d2	E	Ø s	V	SW	Weight [g]
WAF-12	12	40	20	23.5	30 ± 0.12	5.5	12	3	60
WAF-16	16	50	20	27.5	35 ± 0.12	5.5	12	3	80
WAF-20	20	50	23	33.5	38 ± 0.15	6.6	14	4	100
WAF-25	25	60	25	42.0	42 ± 0.15	6.6	16	5	150
WAF-30	30	70	30	49.5	54 ± 0.15	9.0	19	6	300
WAF-40	40	100	40	65.0	68 ± 0.25	11.0	26	8	700
WAF-50	50	100	50	75.0	75 ± 0.25	11.0	36	8	1,200



delivery from stock
time



prices price list online
www.igus.eu/shafts

drylin® R | The Best Bearing for Your Shaft

The combination of shaft and bearing material is critical to the operation of the linear bearing. The correct bearing material depends on many factors, including coefficient of friction and wear, as well as moisture absorption, chemical resistance and temperature resistance.

The all rounder – iglidur® J



The specialist – iglidur® J200



The extreme – iglidur® X



Potential reverse partner	all shaft materials	Aluminum, hard anodized	hardened stainless steel
Application temperature	-50 to +90 °C	-50 to +90 °C	-100 to +250 °C
Best coeff. of friction with	steel shaft	Aluminum, hard anodized	hard chromed steel
Maximum lifetime	Aluminum, hard anodized	Aluminum, hard anodized	hardened stainless steel
Max. surface pressure	35 MPa	23 MPa	150 MPa
Moisture absorption	1.3 % weight	0.7 % weight	0.5 % weight
Volume resistance	$> 10^{13} \Omega\text{cm}$	$> 10^8 \Omega\text{cm}$	$< 10^5 \Omega\text{cm}$
Speciality	lubrication-free	lubrication-free	lubrication-free
Part number	JUM-...	J200UM-...	XUM-...

More information: iglidur® J ► page 93; iglidur® J200 ► page 279; iglidur® X ► page 157



Aluminum shafts in combination with iglidur® J enable high speeds due to the low weight.



Stainless steel shafts combined with iglidur® X, offer maximum resistance at +120 °C. Cleaning in filling machine.



Stainless steel combined with iglidur® J in cut-off grinding machine. Grinding particles and coolants, extreme conditions.



Low-cost guide for workpiece carriage in a machine tool through supported aluminum shaft.









Date:	Phone: +49 2203 969-145 Fax: +49 2203 9649-334
From:	To: igus® GmbH Technical marketing drylin® department P.O.box 90 61 23 51127 Cologne Germany
Phone:	
Fax:	

Lower costs in 45 seconds? Simply fill in, send off, save!!

Step 1:

Please choose the desired shaft material:

 <input type="checkbox"/>	 <input type="checkbox"/>	 <input type="checkbox"/>	 <input type="checkbox"/>
Aluminum, hard anodized	CF-53 steel (1.1213)	1.4034 stainless steel, hardened	1.4034 stainless steel, drawn
 <input type="checkbox"/>	 <input type="checkbox"/>	 <input type="checkbox"/>	
Aluminum, hard anodized	CF-53 steel hv (1.1213 hv)	1.4125 stainless steel, hardened	

Step 2:

Please choose the desired version:

 <input type="checkbox"/>	 <input type="checkbox"/>	 <input type="checkbox"/>
Solid shaft	Low level supported	Standard supported

Step 3:

Please enter the desired dimensions:

_____ Outer-Ø (mm)

_____ Length (mm)

Step 4:

Processing: Please draw a sketch of the machining required

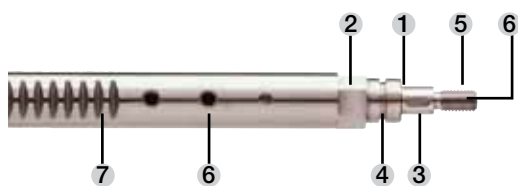

1 Bevel	<input type="checkbox"/> one side	<input type="checkbox"/> both sides
2 Key surface	<input type="checkbox"/> one side	<input type="checkbox"/> both sides
3 Trunion	<input type="checkbox"/> one side	<input type="checkbox"/> both sides
4 Keyway, recess	Quantity _____	
5 Male thread axial	<input type="checkbox"/> one side	<input type="checkbox"/> both sides
6 Female thread axial	<input type="checkbox"/> one side	<input type="checkbox"/> both sides
Female thread, radial	Quantity _____	
7 Other surface processing	<input type="checkbox"/> one side	<input type="checkbox"/> both sides